



PoolCop Evolution

Installer and User Manual



[Change Summary](#)

Date: January 23th, 2024

Manual Version: EV44MANEN

Firmware Version: V44

Product Versions: PoolCop Evolution



March 19 th ,2021	First Edition
June 14 th , 2021	CE/FCC/UL conformity
July 1st, 2021	Pentair SuperFlo VS2
August 26 th , 2021	DataLink Connection
November8th , 2021	PoolCOP Ocean
December 8 th , 2021	Wiring diagram for IntelliCom II
April 26 th , 2022	Water level setpoint
May 11 th , 2022	Circulation Protection
November 20 th , 2022	UKCA Declaration of Conformity
December 19 th , 2022	Water level comments, ACO comments
February 23 th , 2023	Added AQUAGEM, SACI, SCHNEIDER multispeeds pumps/inverters.
March 23 th , 2023	Pentair IntelliFlo3 VSF
April 19 th , 2023	Pin CODE
April 26 th , 2023	Junction blocks
June 29th, 2023	Priorities review for suction valve
September 11th , 2023	EM Configuration – Water level reduction
October 13 th , 2023	Backwashes launched on low flow rate
January 23 th , 2024	Suction valve management

Contents

Section 1 Introduction	7
1.1 Foreword	7
1.2 Notes, Cautions, Warnings and Definitions	7
1.3 Important Information, Safety Notices and Precautions	8
1.4 Information on disposal	10
1.5 Useful Conversions	11
Section 2 Warranty, Records	12
2.1 PoolCop Warranty Registration Card	12
2.2 PoolCop Warranty	13
2.3 Routine Maintenance	14
Section 3 Installation Guide	18
3.1 General	19
3.2 Pre-Installation Preparation and Inspection	19
3.3 Installing the Valve Data Unit	21
3.4 Installing the CCU	24
3.5 Installing Standard Features	38
3.6 Installing Water Treatment	42
3.7 Installing Options	49
3.8 Completing the Installation	62
3.9 Commissioning PoolCop	62
3.10 Post Installation Inspection, Documentation, Procedures	63
Section 4 User Guide	64
4.1 PoolCop Configuration	64
4.2 Keypad and Display Layout	64
4.3 Menus	65
4.4 Using and Settings	72
4.5 Troubleshooting and Alerts	85
Section 5 Programming Guide	88
5.1 Prior to Commencing Programming	89
5.2 Filtration Mode Menu	90
5.3 Auxiliaries Menu	92
5.4 Water and Treatment Menu	95
5.5 Maintenance	104
5.6 Configuration Menu	106
5.7 PoolCop Cloud	122
5.8 Set PIN Code	123
5.9 Circulation Modes	124
Section 6 Internet Connection	125
6.1 Introduction	125
6.2 PoolCop Connection to the Web	126
6.3 Server Connection and Pool Setup	126
6.4 PoolCopilot Functions	130
6.5 Troubleshooting	130
Section 7 Spare Parts and Diagrams	131
7.1 UF1100-D2 Control Connection Unit CCU	131
7.2 CF1220-D2 Kit VDU Upper Part EVO	132
7.3 UF1210-D2 Kit VDU Lower Part Version UF	133
7.4 CF1500 Kit Valve 1.5"	134
7.5 CF2000 Kit Valve 2.0"	135
7.6 SO490x pH+ORP SE Sensor Kit	136
7.7 Decal and Markings Location Diagrams	137
Section 8 Technical Specifications	139
8.1 CE conformity	140
8.2 UKCA conformity	140
8.3 UL/FCC conformity	141

8.4	PoolCOP Evolution.....	142
8.5	Air Temperature Sensor	143
8.6	pH+ORP Sensors.....	143
8.7	Free Available Chlorine Sensor	143
8.8	Backup Waste Valve.....	143
8.9	Flow Switch.....	144
8.10	Water Level Control	144
8.11	XM8 Extension Module	144

Figures

Figure 1 - Serial Number Location.....	12
Figure 2 - VDU on Filter	19
Figure 3 - CCU.....	19
Figure 4 - Air Temperature Sensor	19
Figure 5- Valve Data Unit	21
Figure 6 - Filter connection Kit sample.....	21
Figure 7 - 1.5" valve O-ring.....	22
Figure 8 - 2.0" valve O-ring.....	22
Figure 9 – Diffuser gasket and valve housing greasing.....	22
Figure 10 - Orientation viewed from the top of VDU	22
Figure 11 – Opening the enclosure.....	25
Figure 12 – Connecting DataLink Cable.....	25
Figure 13 - Electrical connection and voltage selector.....	25
Figure 14 – Cables entries in compression glands	26
Figure 15 – Power block usage.....	26
Figure 16 – Relay Terminals and power distribution	26
Figure 17 - Single (or Two) Phase Pump Connection.....	28
Figure 18 - Three-Phase Pump Connection	28
Figure 19 - Pentair IntelliFlo VSD/VSF with IntelliComm or IntelliComm II.....	29
Figure 20 - Pentair IntelliFlo3 VSF.....	30
Figure 21 - Pentair SuperFlo VS/VS2	31
Figure 22 - Hayward Eco Star.....	31
Figure 23 - Hayward VSTD Series	32
Figure 24 - BADU Eco Touch.....	32
Figure 25 - Speck Badu Eco Motion.....	33
Figure 26 - Zodiac FloPro VS.....	33
Figure 27 - Intertek Optidrive e2 Inverter.....	34
Figure 28 - Binary Combination	34
Figure 29 - Davey ProMaster VSD400.....	35
Figure 30 - DAB E.SWIM-E.PRO.....	35
Figure 31 - AQUAGEM iSAVER+, Inverpro, Inverstar, ACIS Varipool, CF Vitalia VS.....	36
Figure 32 - SACI [e]pool, [e]joy.....	36
Figure 33 - SCHNEIDER Altivar ATV212.....	37
Figure 34 - Air Temperature Sensor on J27	38
Figure 35 - Auxiliary Relay Connection.....	39
Figure 36 - Single Phase Auxiliary.....	39
Figure 37 - Three-Phase Auxiliary Connection,	39
Figure 38 - Connecting Inputs in CCU.....	40
Figure 39 - Connecting Inputs in XM8.....	40
Figure 40 - External Thermostat.....	41
Figure 41 - Thermostat Connection	41
Figure 42 - Chemical Low Level Detection.....	41
Figure 43 - Consumables Low Level Detection Connection.....	41
Figure 44 - pH+ORP Sensor with Transport Cap.....	42
Figure 45 - pH+ORP Sensor and Housing	42
Figure 46 - Sensor Housing plug	42
Figure 47 - Sensor connection.....	42
Figure 48 - SO4902 Spacing, Grab Ring Adjustment	43
Figure 49 - SO4903 Spacing, Grab Ring Adjustment	43
Figure 50 - Connecting pH/ORP Sensor.....	43
Figure 51 – 230Vac pH Feeder Pump Connection	45
Figure 52 - Connecting 230Vac Feeder Pump or 24Vac solenoid valve for disinfection.....	47
Figure 53 - Salt System Connection,	48
Figure 54 - Water Line Level Sensor	49
Figure 55 - Buffer Tank Water Level Sensors	50
Figure 56 - Connecting Water Level	50
Figure 57 - Refill Valve and Fittings.....	51
Figure 58 - Cables Entries.....	52
Figure 59 - Terminals.....	52
Figure 60 – Connecting BESGO for pump suction in 230Vac	54
Figure 61 – Connecting Waste Valve.....	55
Figure 62 – Four Modbus IP67 sockets.....	55
Figure 63 – Only one device connected, 3 plugs	55
Figure 64 – FAC on the right plus 1 device connected, 2 plugs.....	55
Figure 65 - Pool Cover Connection (Control and Position Indication)	56
Figure 66 – Connection of MecaTecCenter cover.....	56
Figure 67 – Connection Astral Roussillon Cover.....	57
Figure 68 – Connection SWIMSAFE cover	57

Figure 69 – Connection Aqua-Dec Cover.....	57
Figure 70 – Jet Stream Connection	58
Figure 71 - Flow Switch.....	59
Figure 72 – PVC Saddle.....	59
Figure 73 - Connecting Flow Switch to Input (1)	59
Figure 74 - Flow Switch Paddle Length Adjustment.....	59
Figure 75 - Flow Switch.....	60
Figure 76 – Drill Hole Ø 20mm (¾").....	60
Figure 77 - Connecting Flow Switch to Input (1)	60
Figure 78 – Connecting Eva Optic Led Light.....	61
Figure 79 - CCU Display and Keypad.....	64
Figure 80 - Pressure setting parameters.....	89
Figure 81 - Power Line Adaptors.....	126
Figure 82 - RJ45 Connector for Ethernet.....	126
Figure 83 - CCU Decals and Markings.....	137
Figure 84 – VDU Decals and Markings.....	138

Section 1 INTRODUCTION

1.1	Foreword	7
1.2	Notes, Cautions, Warnings and Definitions.....	7
1.3	Important Information, Safety Notices and Precautions.....	8
1.4	Information on disposal.....	10
1.5	Useful Conversions.....	11

1.1 FOREWORD

We maintain a policy of continuous research and development and therefore reserve the right to make changes and improvements to this manual and any of the products described.

Any reference in this manual to “the pool owner” refers also to the owner of the product or products. The owner may appoint a representative to act on their behalf. The owner retains full and all responsibility for decisions made by and the actions of this representative.

1.2 NOTES, CAUTIONS, WARNINGS AND DEFINITIONS

Within this manual some information is highlighted in the form of notes, cautions, warnings, etc. The following definitions apply throughout:



NOTE
A step, procedure, technique, etc. which is considered important or essential to emphasize.



CAUTION
A step, procedure, technique, etc. which could result in damage to equipment if not carefully followed.



WARNING
A step, procedure, or technique which could result in personal injury if not carefully followed.



Read the installation manual and all warnings in full.
Follow all instructions.



WEAR HAND PROTECTION
Always wear correct chemical resistant hand protection when handling chemicals.



EYE PROTECTION
Always wear correct eye protection when handling chemicals.

May An acceptable or suggested means of accomplishment.

Should Normally used to indicate a preferred but non-mandatory method of accomplishment.

Must, will The instructions or procedures are mandatory.

As installed The instructions or procedures depend on the specific model or version of equipment installed.

If installed	The instructions or procedures depend on whether the equipment is installed.
As required	The instructions, procedures, or requirements are mandatory depending on relevant conditions.
Verify	A planned change in an indication, annunciation, or message is observed to occur as expected. Check the state or condition prior to proceeding.
-	-
-	-

1.3 IMPORTANT INFORMATION, SAFETY NOTICES AND PRECAUTIONS



WARNING:
Read the security instructions attentively before any use.
Instructions given below are all important for your safety.

PoolCop is a product of superior design, engineering and manufacture and should be treated with care. The information contained in this section will help you fulfil the warranty obligations and make use of this product for many years. Always respect all norms for electrical, hydraulic, chemical and swimming pool installation and operation. No responsibility will be accepted for installation or use of this product outside the applicable norms. For the swimming pool to remain a place of pleasure and user-friendliness, it is necessary to take care of the safety of those who bathe and of the installation standards. The electric connections must be carried out, according to the applicable norms, by a qualified person.



WARNING:
Keep the equipment and all associated equipment out of the reach of public and animals.



WARNING:
Inappropriate use can cause accidents, bodily injury, fire, electrocution, system failure and flooding.



CAUTION:
Keep the covers closed at all times when not interacting with the equipment to prevent inadvertent damage.



CAUTION:
Do not drop any objects into any openings of the equipment and the associated equipment as this could cause serious damage.



CAUTION:
Equipment and the associated equipment must be located in an area protected from the elements.



CAUTION:
Equipment are splash proof but must never be exposed to water or other liquids for extended periods. Precipitation, humidity and liquids contain minerals that will corrode electronic circuits.

**WARNING:**

Equipment should not be installed near flammable gas or products.
In the event of the escape of gas or dangerous products, there is risk of fire and explosion.

**WARNING:**

Do not remove any of the protective covers on the equipment or the associated equipment. Touching parts inside these compartments could result in an electrical shock and/or damage to the system.

**CAUTION:**

Do not use harsh chemicals, solvents or detergents to clean the equipment.
Wipe with a soft cloth, slightly dampened in a mild soap-and-water solution.

**WARNING:**

In case of malfunction or if an anomaly occurs (such as a smell of burning from the unit), disconnect the power supply and contact the installer.

**CAUTION:**

Use only approved replacement parts. Unauthorized parts and/or modifications could damage the entire system and will void your warranty.

**CAUTION:**

Verify that any auxiliary equipment is correctly installed as per the manufacturer's instructions and is compatible with the equipment and installation.

**WARNING:**

Installation requires a properly protected power source.
Refer to local regulation for ground fault protection.

**WARNING:**

Always mount controller in a safe area not subject to damage by moving objects.
Never bury controller power cords.

**WARNING:**

Always disconnect power and ensure that the electrical current is shut off before servicing.

**WARNING:**

Any person using, adjusting, or monitoring the equipment must be at least 18 years of age and be familiar with these instructions and the contents of this manual.

**WARNING:**

If the equipment is used for treatment control, or to control any equipment that does not have no-flow protection a water circulation flow detection sensor must be correctly installed and configured where required.

**WARNING:**

Always take and record manual water chemistry readings in conformance with Health Department requirements. Although automated controllers are a great aid in maintaining healthy water quality, controllers are not a substitute for manual water testing with an accurate test kit.

**WARNING:**

Always read and become familiar with Material Safety Data Sheets (MSDS) and safe handling instructions for all chemicals used with the controller.

**CAUTION:**

The automatic controller should not be installed where it is accessible to the public.

1.4 INFORMATION ON DISPOSAL



If you wish to discard electrical and electronic equipment(EEE), please contact your dealer or supplier for further information.

1.5 USEFUL CONVERSIONS

		Temperature													
Centigrade °C	-12	-7	-1	0	4	10	16	21	27	32	38	43	49	54	60
Fahrenheit °F	10	20	30	32	40	50	60	70	80	90	100	110	120	130	130

		Pressure													
Bar	0	0.1	0.2	0.3	0.4	0.5	0.6	0.7	0.8	0.9	1.0	1.2	1.4	1.6	1.9
kPa	0	10	20	30	40	50	60	70	80	90	100	120	140	160	190
Psi	0	1.5	2.9	4.4	5.8	7.3	8.7	10.2	11.6	13.1	14.5	17.4	20.3	23.2	27.6
"Hg	0	3.0	5.9	8.9	11.8	14.8	17.7	20.7	23.6	26.6	29.5	35.4	41.3	47.3	56.1

		Volume													
m³	20	40	60	80	100	120	140	160	180	200	220	240	260		
USG	5300	10600	15800	21100	26400	31700	37000	42300	47600	52800	58100	63400	68700		

		Flow Rate													
m³/hr	2	4	6	8	10	12	14	16	18	20	24	28	32		
GPM	9	18	26	35	44	53	62	71	79	88	106	123	141		

		Flow Rate													
ml/h or l/hr	0.3ml	20ml	40ml	60ml	140ml	210ml	320ml	1l	1.5l	3l	6l	12l	24l		
GPD	9	0.13	0.25	0.38	0.89	1.33	2.03	6.34	9.51	19	38	76	152		

Section 2 WARRANTY, RECORDS

2.1	PoolCOP Warranty Registration Card	12
2.2	PoolCOP Warranty	13
2.3	Routine Maintenance	14
2.3.1	Routine Pool Maintenance	14
2.3.2	PoolCOP Maintenance	14
2.3.3	Pool Winterization	17
2.3.4	Re-Commissioning the Equipment	17

2.1 POOLCOP WARRANTY REGISTRATION CARD

Review the warranty details in the product manual. Detach or scan this warranty card. Promptly complete and return this warranty registration. If information is incomplete or missing it will result in the product not being registered.		PCFR SAS 130 Boulevard du Nord 84160 CUCURON France www.poolcop.com contact@poolcop.com
www.poolcop.com		
Product: <input type="checkbox"/> PoolCOP 1.5" <input type="checkbox"/> PoolCOP 2"		
Brand / Model N°:	Name of Installer:	
Serial Number:	Installer's Company:	
Purchased From:	Telephone:	
Date of Purchase: DD / MM / YYYY	Date of Installation: DD / MM / YYYY	
SURNAME:	Address:	
First Name:	City / Town:	
e-mail:	Postal Code:	
Telephone:	Country:	
<input type="checkbox"/> I would like to receive product maintenance reminders. <input type="checkbox"/> I would like to receive product information and news.		
Signature: _____	Date: DD / MM / YYYY	

The serial number is located on the left side of the Control and Connection Unit (CCU):

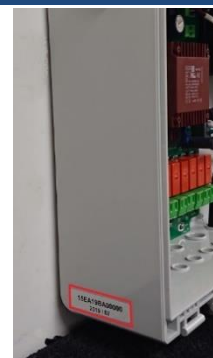

Figure 1 - Serial Number Location

2.2 POOLCOP WARRANTY

Before using the product, we recommend that you carefully read the user manual in which you will find all the usual precautions.

Return the warranty registration card completed with the serial number to activate the warranty. This warranty applies only if the defective product is presented within the warranty period, accompanied by the original invoice or receipt (clearly indicating the purchase date, the model of the device and the reseller's name). PCFR reserves the right to refuse warranty service if these documents are not presented or if they are incomplete or illegible. The warranty will not apply if the model name or serial number on the product has been altered, wiped out, deleted, torn, perforated or made illegible.

The warranty is valid for 2 (two) years from the date of delivery (see Conditions). This warranty does not cover consumables or parts with limited lifespan (e.g. batteries, sensors, seals and O-Rings ...). The warranty is automatically invalidated if the customer does not notify PCFR of the latent defect or the alleged non-compliance within 20 (twenty) days from its discovery. The customer is responsible for proving the date of the discovery.

PCFR is only obliged to repair or replace, free of charge, defective or nonconforming parts, at its discretion, and without the customer being entitled to obtain damages for any cause whatsoever. Original spare parts are available from PCFR. The use of other than genuine parts voids the warranty.

Terms:

- This product is covered by a limited warranty of 2 (two) years, excluding consumables or parts with limited warranty (see below).
- The warranty start date is defined as follows
 - This is the date of commissioning, if the installer returns the warranty registration card (see §2.1).
 - Otherwise, if the registration card is not returned, the billing date of the first-level distributor to the first client will be used.
- The product warranty period will be reduced to 1 (one) year if no proof of the first annual service can be provided. The first annual service must be conducted and recorded in the maintenance book by the installer or a person authorized by PoolCOP. The annual service checklist and the maintenance card are detailed in the user manual (a copy of this manual can be provided on request).
- If the product is not installed by the installer or an authorized reseller, the warranty is limited to 90 days.
- PoolCOP provides no warranties (express, implied, statutory or otherwise) for the product, the product software or the software accompanying the product, regarding the accuracy of the information provided or suitability for a particular purpose.
- Consumables and parts with limited warranty:
 - 12V SLA battery is guaranteed for 1 (one) year from the date of delivery of the product.
 - The pH or pH+ORP sensor is guaranteed for 2 (two) years from date of commissioning.
 - The valve gasket is guaranteed for 2 (two) year from its date of commissioning and subject to normal use.

The warranty does not cover:

- Defects and deterioration of products due to abnormal conditions of storage, especially in case of an accident of any kind whatsoever, will void the product warranty. The warranty applies only to products that have become the property of the buyer. It applies only to products wholly distributed by PCFR. The warranty is automatically voided should the products be used under conditions for which they were not designed. A design flaw is not a latent defect and customers of PCFR are deemed to have received all the technical information on products sold. PoolCOP does not cover damage resulting from wear requiring an adaptation or a special assembly, abnormal or not, of the product unless it was conducted under PCFR's supervision.
- Viral infections or the use of the product with software not supplied, or software incorrectly installed.
- Neglect.
- A loss of water tightness of the Valve Data Unit following an assembly error, installation error or a lack of attention on a sealing element or its installation (sensors, electrodes, O-rings, hoses, clamps, etc.).
- Accidents, fire, liquids, chemicals other substances, flooding, vibrations, excessive heat, improper ventilation, power surges, excess or inadequate power supply, radiation, electrostatic discharge including lightning, other forces and external influences.
- Transportation costs and the risks associated with product replacement or repair.

Exclusions and Limitations:

PoolCOP is not responsible for the consequences of action taken in response to a displayed value. The results obtained by the product are not the responsibility of PCFR, whatever the causes and consequences. It is the user's responsibility to verify the displayed values and the proper functioning of the unit.

In the context of this warranty, the PCFR's sole obligation is to repair or replace products which meet the conditions of this warranty. PoolCOP is not responsible for any loss or damage relating to products, to service, to this warranty or any other, including:

- Loss of use of the pool.
- Financial losses.
- Price paid for the product.
- Loss of profit revenue, data, enjoyment or use of the product or associated products.
- Loss or indirect loss or accidental damage.
- Any direct or any indirect prejudice linked to the unavailability of the product for whatever duration.

2.3 ROUTINE MAINTENANCE

2.3.1 Routine Pool Maintenance

Routine basic maintenance needs to be carried out to ensure that the pool remains in good condition. This guide does not describe how to maintain pools and water treatment. Follow company procedure and manufacturer's instructions.

2.3.2 PoolCOP Maintenance

Basic maintenance needs to be carried out to ensure that the equipment successfully manages the pool.

2.3.2.1 Regular Periodic Checks

- Check for Alerts: Alerts and messages are the means of communication about the state of the pool. Check regularly or at any time when in doubt about a condition.
- Check and Replenish Consumables: Ensure that consumables level is always sufficient. Consumables must be replenished timeously to ensure that optimal treatment and balance is maintained in the pool.
- Check General Condition: Check the general condition of the equipment as well as the electrics, hydraulics and all accessories.

**WARNING:**

Chemical consumables are hazardous substances and must be handle with extreme care and caution.

2.3.2.2 PoolCOP Genesis Annual Service

The equipment requires an annual service by the installer. See the equipment Maintenance Card (2.3.2.4) for details and dates due. Essential service items are:

- Check battery every 12 months. The battery should last for 3-5 years, and will be replaced if a malfunction occurs.
- Check water balance.
- Check pH sensor calibration every 12 months (or as required by code).
- Check for leaks. Lubricate diffuser gasket with pure silicon grease.
- Check for leaks.
- Check condition of the pool equipment.
- Check pool electrical safety and bonding as per local code.
- Replace the valve diffuser every two years.

2.3.2.3 PoolCOP Evolution Site Visit Checklist

The following checklist will maintain equipment in good condition and optimize service calls.

Date		Firmware version	Client	Signature	
Visit	Maintenance	Category	Item	Checked	Replaced
X	X	General	Check Power and 12VDC Supply LEDs on CCU.		
X	X		Check data: Pressure Temperature pH ORP Date and Time		
X	X		Essential pool water data: TAC pH CyA ORP		
X	X	Leaks	Start pump and check no leaks, check pressure.		
X	X		Check no leaks inside/outside equipment room.		
X	X	Valve rotation	If pool water level is ok do a backwash. Check valve rotation (no abnormal noise). Check filter cleanliness.		
X	X	Pressure	Stop the pump; check the no pressure (static head). Set/adjust protection pressure accordingly.		
X	X	pH	Verify TAC >80 ppm. Stop the pump, command a manual pH reading. If not OK check/calibrate sensor.		
X	X	pH Control	Check pH feeder pump operation from the pH menu, using the "Priming" feature		
X	X	Disinfection Control	If using ORP regulation Check disinfection equipment operation from the ORP menu, using the "Priming" feature		
X	X	Battery	Put valve in waste position (if possible, bypass otherwise). Remove 220Vac power supply and check valve rotation in safe position. in not ok, check battery voltage (>11.5V). When battery is disconnected, charging circuit voltage should be > 13.5V.		
	X	Valve gasket	Unloose PoolCOP from valve housing, check and grease gasket. If damaged, replace the rotating part.		

2.3.2.4 PoolCOP Evolution Maintenance Card

PoolCOP Evolution Maintenance Card	Date Due	Date Carried Out	By:	Notes:
First Installation	-	/ /		
1st Annual Service <input type="checkbox"/> Check Battery <input type="checkbox"/> Calibrate Sensors <input type="checkbox"/> Check Leaks <input type="checkbox"/> Inspect Valve Gasket, Grease.	/ /	/ /		
2nd Annual Service <input type="checkbox"/> Replace Valve Diffuser <input type="checkbox"/> Check Battery <input type="checkbox"/> Calibrate Sensors <input type="checkbox"/> Check Leaks, Grease.	/ /	/ /		
3rd Annual Service <input type="checkbox"/> Check Battery <input type="checkbox"/> Calibrate Sensors <input type="checkbox"/> Check Leaks <input type="checkbox"/> Inspect Valve Gasket, Grease.	/ /	/ /		
4th Annual Service <input type="checkbox"/> Replace Valve Diffuser <input type="checkbox"/> Check Battery <input type="checkbox"/> Calibrate Sensors <input type="checkbox"/> Check Leaks, Grease.	/ /	/ /		
5th Annual Service <input type="checkbox"/> Check Battery <input type="checkbox"/> Calibrate Sensors <input type="checkbox"/> Check Leaks <input type="checkbox"/> Inspect Valve Gasket, Grease.	/ /	/ /		
6th Annual Service <input type="checkbox"/> Replace Valve Diffuser <input type="checkbox"/> Check Battery <input type="checkbox"/> Calibrate Sensors <input type="checkbox"/> Check Leaks, Grease.	/ /	/ /		
7th Annual Service <input type="checkbox"/> Check Battery <input type="checkbox"/> Calibrate Sensors <input type="checkbox"/> Check Leaks <input type="checkbox"/> Inspect Valve Gasket, Grease.	/ /	/ /		
8th Annual Service <input type="checkbox"/> Replace Valve Diffuser <input type="checkbox"/> Check Battery <input type="checkbox"/> Calibrate Sensors <input type="checkbox"/> Check Leaks, Grease.	/ /	/ /		
9th Annual Service <input type="checkbox"/> Check Battery <input type="checkbox"/> Calibrate Sensors <input type="checkbox"/> Check Leaks <input type="checkbox"/> Inspect Valve Gasket, Grease.	/ /	/ /		
<p>PoolCOP Genesis is guaranteed for 2 years provided that warranty conditions are met.</p>				

2.3.3 Pool Winterization

2.3.3.1 Active Winterization



CAUTION

Active Winterization is not possible with all installations or in all areas, and less desirable in very cold areas where solid freezing is a bigger risk.

Maintaining the pool year-round avoids chemical shock treatment, the use of expensive treatment and cleaning products, and much labor. Suggested Settings:

- Commercial Pools, required filtration modes are:
 - **24/24** if the pump start/stop is controlled by the pump relay.
 - See 5.2 Filtration Mode Menu if the pump is controlled by the pump relay for other modes.
- Residential Pools, recommended modes are:
 - See 5.2 Filtration Mode Menu if the pump is controlled by the pump relay for suitable modes.
- Set freezing mode protection **ON** in the Pool Data menu.
 - Filtration will run at any time should a freezing risk be detected based on water and air temperatures (as installed).
 - for details and settings.
- pH regulation will continue to function normally at all temperatures.
- Disinfection is stopped below the Disinfection Minimum Temperature as set in the Configuration/Maintenance menu.

2.3.3.2 Passive Winterization



CAUTION

Passive Winterizing is not possible with all installations or in all areas. Get the advice of a pool qualified installer on the best solution in the area and with the type of pool.

It is recommended that the equipment remains ON and electricity supply connected to keep internal circuits warm and dry.

Suggested Settings:

- The pump and all accessories (pool cleaner pump, heat pump, etc.) should be switched OFF at the appropriate circuit breaker.
- Select the filtration mode STOP.
- Purge the water circuit.
- Ensure that the water level control is stopped (Configuration/Water Level; the mode must be "Read Only"). Purge the refill circuit.
- Remove the pH+ORP sensor and store in a location away from risk of freezing; use the sensor transport cap supplied or suitable container and ensure the end of the sensor remains moist.
- Remove the sensor holder and seal with the original plug.

2.3.4 Re-Commissioning the Equipment

When re-opening the pool after passive winterization (or out of service for a period of time) carry out the following procedure:

- Replace the pH+ORP sensor if removed.
- Perform an annual service (see 2.3.2.2).
- Continue with the normal maintenance cycles of the pool and the equipment.

Section 3 INSTALLATION GUIDE

3.1	General	19
3.2	Pre-Installation Preparation and Inspection.....	19
3.3	Installing the Valve Data Unit.....	21
3.3.1	Valve housing mounting on filter	21
3.3.2	Mounting the Valve Data Unit.....	22
3.4	Installing the CCU.....	24
3.4.1	Mounting the CCU.....	24
3.4.2	Electrical Connection.....	24
3.4.3	Cables Selection and Connection.....	24
3.4.4	Connecting a Single Speed Pump	28
3.4.5	Connecting a Variable Speed Pump	29
3.5	Installing Standard Features.....	38
3.5.1	Air Temperature Sensor	38
3.5.2	Connecting Auxiliary Relays	39
3.5.3	Connecting Inputs	40
3.6	Installing Water Treatment.....	42
3.6.1	General	42
3.6.2	Installing the Water Condition Sensor.....	42
3.6.3	pH Control.....	43
3.6.4	Disinfection.....	46
3.6.5	Free Available Chlorine Sensor.....	48
3.7	Installing Options.....	49
3.7.1	Water Level Control	49
3.7.2	Installing XM8.....	52
3.7.3	Connecting BESGO 3 for pump suction	54
3.7.4	Connecting an Automatic Valve on Waste Line.....	55
3.7.5	Using Modbus Hub connectors to connect Modbus devices	55
3.7.6	Connecting Equipment.....	56
3.7.7	Circulation Flow Detection Sensor.....	58
3.7.8	Connecting an Eva Optic led pool light.....	61
3.7.9	Connecting an heating system.....	61
3.8	Completing the Installation.....	62
3.9	Commissioning PoolCOP	62
3.10	Post Installation Inspection, Documentation, Procedures.....	63
3.10.1	Post Installation Inspection.....	63
3.10.2	Post Installation Documentation.....	63
3.10.3	Post Installation Procedures	63

3.1 GENERAL

- Installation of the equipment will be done only by qualified and experienced installers.
- Failure to correctly install the equipment according to this manual will void the warranty.
- This installation manual is intended to be used as a checklist; check the boxes next to installation steps ensuring that all steps are completed in the correct sequence.
- It is recommended that the Configuration Card be used to keep notes of settings, configuration and notes during the installation; this will facilitate easy completion of the required post installation documentation.



NOTE:

**The PoolCOP is a management system, and not a repair system.
Installers must verify that the swimming pool and all equipment are in an acceptable condition prior to commencing the installation.**

As the installer, if you are not satisfied with the condition of the pool or any equipment these must be repaired and tested prior to commencing the installation of the equipment.

As the installer, ensure that any repairs are only carried out with the full knowledge and consent of the pool owner.

Contact PoolCOP with any queries and for more information.

3.2 PRE-INSTALLATION PREPARATION AND INSPECTION

A PoolCOP Genesis installation has the following obligatory components:

- Valve Data Unit (VDU):** Installed in the pump house, replacing the multiport valve. Each filter installation requires its own Valve Data Unit.



Figure 2 - VDU on Filter

- CCU:** Installed on the wall, typically adjacent to the electrical junction box. The CCU contains the electrical connections for control of all pool equipment and provides connection and power for all sensors



Figure 3 - CCU

- An **Air Temperature Sensor** is supplied with the CCU: optionally use the supplied sensor for freezing detection, alternatively use an external thermostat.



Figure 4 - Air Temperature Sensor



WARNING:

If the equipment is used for treatment control, or to control any equipment that does not have no-flow protection, a water circulation flow detection sensor must be correctly installed and configured where required.

- PoolCOP Evolution Options:

- **Water Level Control:** Water level is controlled by means of a water level sensor, a control valve and a water supply located on the equipment pad (installed in the pool water return line).
- Water Treatment Control:
 - **pH Control:** using dosing of pH- or pH+.
 - **Disinfection:** using ORP control, timed volumetric dosing.
- **Control of auxiliary equipment:** Up to 6 auxiliary relays allow control of other equipment (lighting, heating, cleaners, irrigation, etc.) and external water treatment equipment.
- **Waste Valve** on waste outlet for increased security against sewer leaks.
- **Drum Level Sensors** for detection of drums requiring replenishment.
- **XM8** adds an extra 8 inputs and 8 relays outputs.
- **PoolCOP Chlorine Sensor FAC** for reporting and alerting of Free Available Chlorine in ppm (DPD1).
- **Flow Switch** a water circulation flow detection sensor can be installed for additional safety or if required to protect treatment or external equipment.

Before commencing installation, the installer should confirm the following with the pool owner:

- Valve Data Unit is compatible with the pool's filter.
- Preferred location of CCU.
- Preferred locations for the various water sensors.
- Preferred location of the Air Temperature Sensor.
- Water Level Control (optional):
 - Location of sensor and routing of the water level sensor wiring.
 - Routing of water supply to water level controller valve.
 - Preferred location of water shut off valve.
- Water Treatment (optional):
 - Type of pH control.
 - Type of disinfection.
 - Type of oxidation remnant, if required.
- Auxiliary equipment connected and controlled by equipment (optional).
- Remote control: Routing of RJ45 cable or Powerline Adapters or Wi-Fi Adapter details and codes.
- Pool Condition:
 - There is no debris in the pool.
 - Pool water is acceptably clean.
 - Water balance is in the acceptable range.
 - Condition of the pool's electrical system in general and the electrical box in particular.
 - Condition of the filter, and the filter media.
 - Skimmer and pump pre-filter baskets are clear of debris.
 - Pool light and other equipment is working.

While the pool pump and filtration system are running, installers must verify the following:

- The condition of the pool pump and motor.
- Leaks on the entire plumbing and filter system.
- The hydraulic coefficient of the filtration system is adequate.

When ready to commence the installation, the installer must:

- Disconnect all electrical power to the pool and systems.
- Close all valves, and if necessary, block all inlets to and outlets from the pool. This is especially important if the water level of the pool is higher than the pump and filter installation.

3.3 INSTALLING THE VALVE DATA UNIT

Due the large variety of possible installations, it may be necessary to adapt piping and connectors to fit the Valve Data Unit to the filter and pump combination. Use standard and acceptable pool plumbing parts and norms at all times. PoolCOP is supplied with a standard multiport valve housing (1.5" or 2.0").

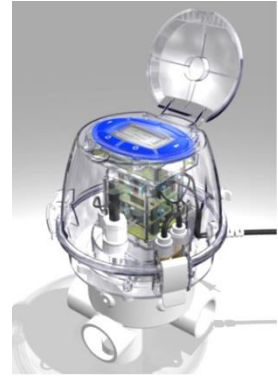

Figure 5- Valve Data Unit



CAUTION:

Incompatible multiport valve housings may not allow correct functioning of the automatic valve and the filtration system, and will invalidate the warranty.



WARNING:

Verify that all electricity supply is disconnected and that the water supply is shut off prior to commencing the installation.

3.3.1 Valve housing mounting on filter

For renovation, first remove the old valve housing from the filter by loosening the filter screws

Install the PoolCOP valve housing. To facilitate the installation, Filter Connection Kits (in 1.5" or 2.0" versions) are available; these connect the supplied valve housing to the filter bulkhead fittings. Follow Connection kit guidelines.

Make sure the gluing is dry and strong enough before mounting the Valve Data Unit on the valve housing.



Figure 6 - Filter connection Kit sample



CAUTION:

Incorrect gluing negatively affects the bonding quality and water tightness. The valve housing is made with ABS, slip threaded pieces and PoolCOP connector kits are in ABS.

- Never use solvents, solvent based cleaners or primers.**
- Never use solvent based adhesives.**
- Never use glue for "flexible" or for "rigid and flexible" PVC.**
- ONLY lightly sand the parts to be glued.**
- ONLY use only provided glue.**

3.3.2 Mounting the Valve Data Unit

1.5" Valve: Place the O-ring gasket on the bottom of the VDU.



Figure 7 - 1.5" valve O-ring

2.0" Valve: Place the O-ring gasket on the 2.0" adapter.



Figure 8 - 2.0" valve O-ring

- Fit the Valve Data Unit with O-ring into the multiport valve housing.
- Verify the orientation of the Valve Data Unit:
 - **SIDE MOUNT** On a standard side mount sand filter the Valve Data Unit hinge will be closest to the filter and directly above the filter connector pipes. The waste pipe will be on the right-hand side.
 - **TOP MOUNT** On a standard top mount filter, check the alignment indicator on the valve housing and ensure that the waste pipe is at the three o'clock position with respect to the PoolCOP Valve Data Unit.



CAUTION

Apply a layer of pure silicon grease (provided) on the wagon wheel gasket and inside the valve housing. You can also apply some grease or lubricant to the O-ring gaskets.

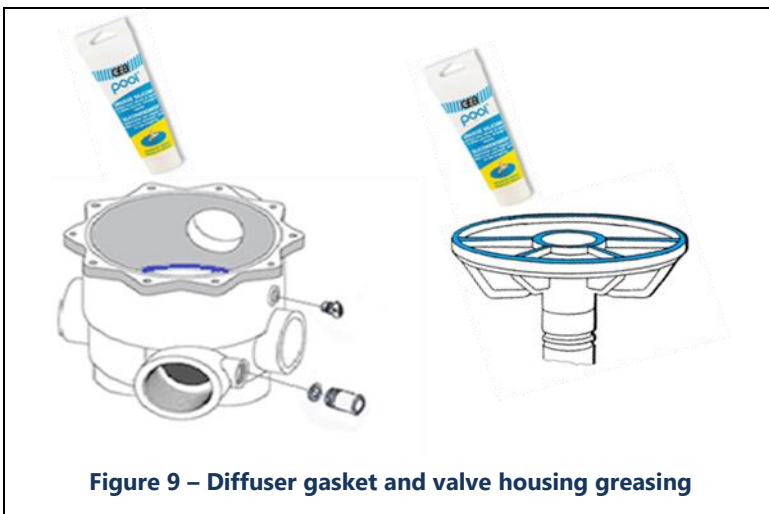

Figure 9 – Diffuser gasket and valve housing greasing

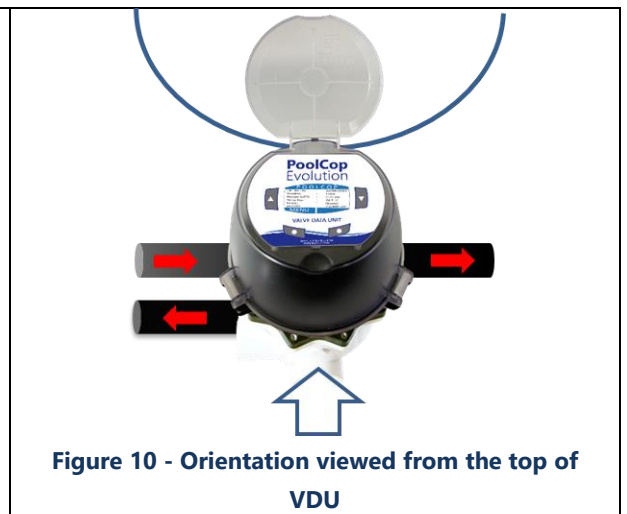

Figure 10 - Orientation viewed from the top of VDU



CAUTION:

Verify that the Valve Data Unit is correctly orientated before continuing.

- Using a spherical head 5mm Allen key and 10mm open spanner:
- 1.5" Valve: Secure the Valve Data Unit to the valve housing using the 4 short and 2 long cap screws and all 6 nuts (the flat washers will be placed under the heads of the cap screws).
- 2.0" **Valve**: Verify that the Valve Data Unit is correctly secured to the 2.0" adapter ring by means of the 4 short and 2 long cap screws into the captive nuts in the adapter ring (with flat washers placed under the heads of the cap screws). Using a 5mm spherical head Allen key, secure the adapter ring to the valve housing using the 10 cap screws and provided nuts.

**CAUTION:**

**Fasten in a cross-over sequence.
Do not over-tighten the screws .**

3.4 INSTALLING THE CCU

3.4.1 Mounting the CCU



CAUTION:
Use only existing predrilled holes for mounting the CCU. Any additional holes or openings risk water entry, foreign matter penetration and damage and void the warranty.



CAUTION:
The CCU must be mounted with the cable compression glands and cable entries at the bottom. Incorrect mounting risks water entry, foreign matter penetration and damage and void the warranty.



CAUTION:
All unused compression glands must be blocked with the supplied red blanking plugs. If an RJ45 cable is not fitted, the connector must be blocked with the supplied cap.



CAUTION:
The ingress protection rating is IP54. Ensure that the unit is installed in a location that complies with the rating limitations.

The CCU must be mounted:

- In proximity to the filter/s and pump/s if controlled.
- The Flow Switch cable is 2 meters (6.6') long and can be lengthened using suitable wire.
- With the cable entry compression glands at the bottom
- Essentially vertically and level.
- Securely, it is provided with 4 screws and 4 anchors for concrete. Ensure the mounting surface material is compliant with these anchors or use the correct anchor according to local building code regulation.
- In a location not exposed to excessive dust.
- In a location not exposed to jets of water.

3.4.2 Electrical Connection

Read 1.3 "Important Information, Safety Notices and Precautions" before starting electrical connection.



CAUTION:
The electric standard applicable is IEC 60364-7-702 (NFC15-100 in France). It is mandatory that the installation complies with this standard. When installing the device, the installer must ensure that the circuitry is protected by a 30mA differential circuit breaker. The installer must also ensure a bipolar external circuit breaker to remove electrical power so that maintenance operations can be done safely.

CCU box is provided with compression glands size PG9 (for external diameter 3.5mm to 8mm, tightening 13Nm), PG11 (for external diameter 4mm to 10mm, tightening 20Nm) and PG13.5 (for external diameter 6mm to 12mm, tightening 25Nm). The cables must pass through the appropriate compression gland size according to their diameter and the compression gland must be tightened to the recommended setting to secure the cable.



CAUTION:
Make sure the wall socket is surge protected at 16A maximum.

3.4.3 Cables Selection and Connection

- For DCCU power supply : **03VV or H05VV** with section **3G1.5**.
- For pump and auxiliary control: **H03VV or H05VV** with section **2x0.75**.
- Smaller sections and multiple conductor cables can be used depending on amperage (ex **JZ-602 12G0.5**).
- Cable selection must conform with local regulations.

- Open the enclosure using the cover clips and a flat screwdriver.



Figure 11 – Opening the enclosure

- Route the compression gland of DataLink Cable (from VDU) into the enclosure open entry (left side).
- Connect Datalink:
 - 7 pins plug into J4.
 - 9 pins plug into J5.
 - RJ45 male end to the RJ45 pass-through connector.

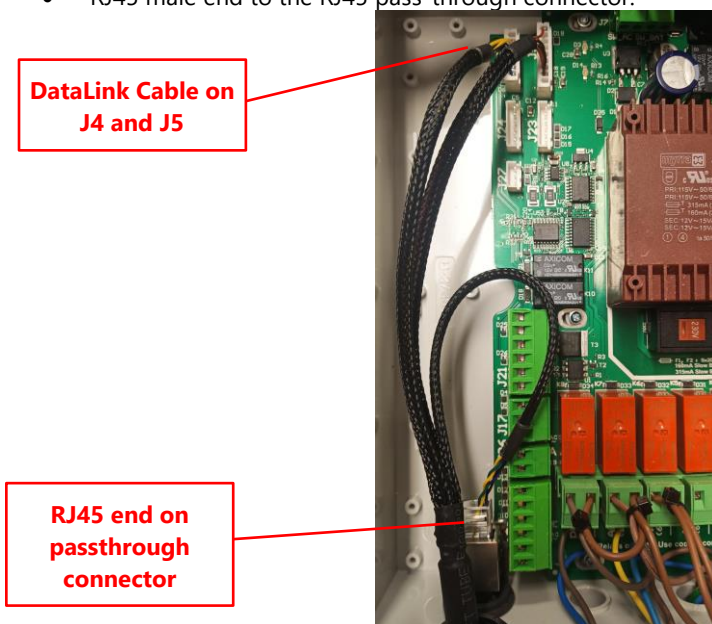

Figure 12 – Connecting DataLink Cable

- Electrical connection and voltage selector

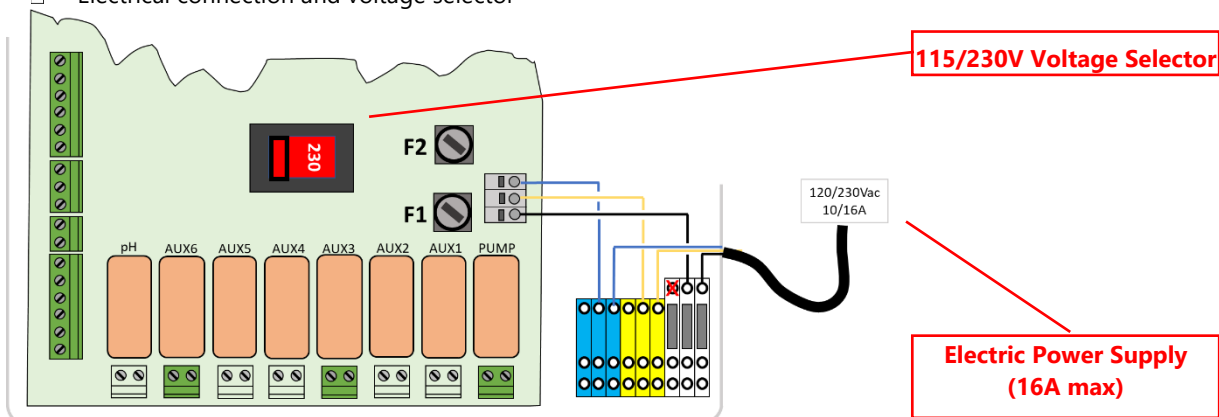

Figure 13 - Electrical connection and voltage selector

- Before powering up, Check the 115V/230V selector position; slide selector to the left for 220/240Vac power supply, slide to the right for 115/120Vac.



CAUTION:
 If switching to 115V for any reason, the fuses F1 and F2 must be replaced by 315mA slow blow 5x20mm cartridge fuse.

- Cables entries in compression glands.

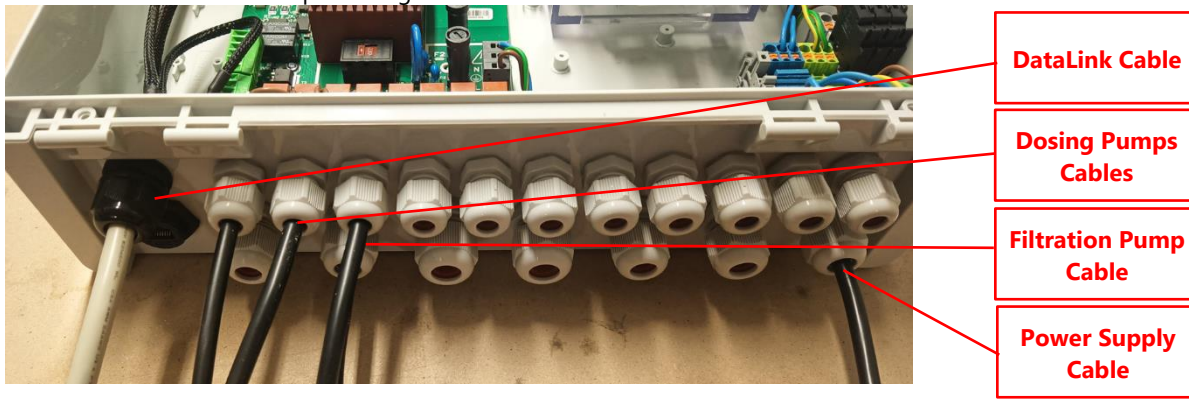

Figure 14 – Cables entries in compression glands

- Power distribution blocks usage:
 - The power distribution blocks allow to distribute power to connected devices.
 - Neutrals (blue) are joined together.
 - Earth Protections (Green/Yellow) are joined together.
 - Hot Lines are splitted as per below:

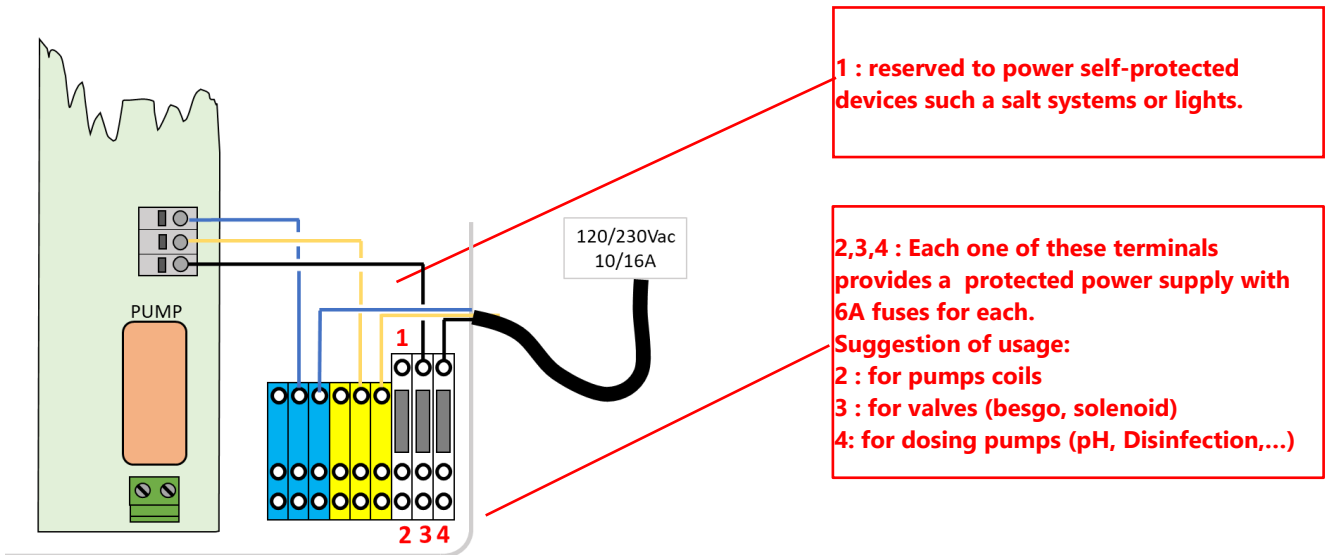

Figure 15 – Power block usage

- Relay Output Connection:

On relays terminal, always use tie-wraps to join cables together as close as possible to the terminal.

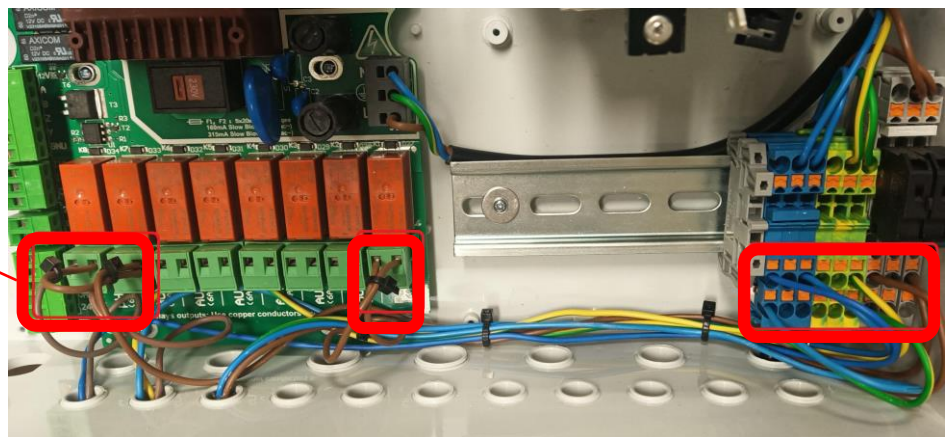

Figure 16 – Relay Terminals and power distribution

- The pump relay K1 is a dedicated relay for primary pump control and will not be used for other functions.
- Auxiliaries can be connected via relays K2 - K7.
- See the appropriate section of this manual for connection details.
- Feed auxiliary equipment control cables through appropriate compression gland into the CCU.
- When using multi strand cable, use a cable end.



WARNING:
Always tie wrap the wire ends together as close as possible to the relay connector.

Function	Relay Label	Relay ID	Connector	Rating	Examples of possible use
Primary Pump Control	PUMP	K1	J6	6A	Pump control using a 24V or 230Vac coil relay.
AUX or VS pump	Aux1	K2	J6	6A	Pool lighting, etc.
AUX or VS Pump	Aux2	K3	J6	6A	Pool heating relay control, etc.
AUX or VS Pump	Aux3	K4	J6	6A	Pool cleaner booster pump, etc.
AUX	Aux4	K5	J19	6A	Garden lighting, irrigation control, etc.
AUX	Aux5	K6	J19	6A	Pool treatment equipment, etc.
AUX or ORP Control	Aux6	K7	J19	6A	Water treatment, etc. This relay dedicated to integrated ORP if installed.
pH Control	pH	K8	J19	6A	pH Control.

Table 1 Relays and Power Ratings



WARNING:
Never exceed the listed power ratings.
Always conform to local installation norms and requirements.



CAUTION:
If you are unsure of the applicable wattage rating, contact the distributor of the auxiliary apparatus to confirm prior to connection.



WARNING:
Max Output 12VDC is 100mA. Max Output 24Vac is 450mA

3.4.4 Connecting a Single Speed Pump

- Disconnect the power supply to and from the existing pump timer.
- Disconnect the pump timer, or remove if appropriate, noting the wires that are connected to the pump or pump protection and relay.
- Connect the pool pump control circuit to the relay K1 (labelled "PUMP") on J6.



CAUTION:
This is a dedicated relay and will only be used for the pool pump.



CAUTION:
Controlling a pump will require a separate pump relay with adequate switching capacity.
This relay will be controlled via the PUMP relay K1.

- If connecting a **single (or two) phase pump**, it is recommended that the pump has an independent supply, and that the PUMP relay K1 be used to control the external pump relay.

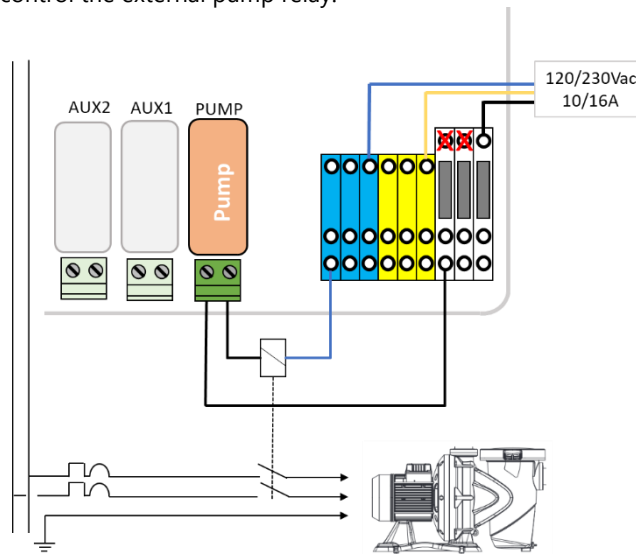

Figure 17 - Single (or Two) Phase Pump Connection.

- If connecting a **three-phase pump**, the pump must have an independent supply, and the PUMP relay K1 will be used to control the external two- or three-phase pump relay.

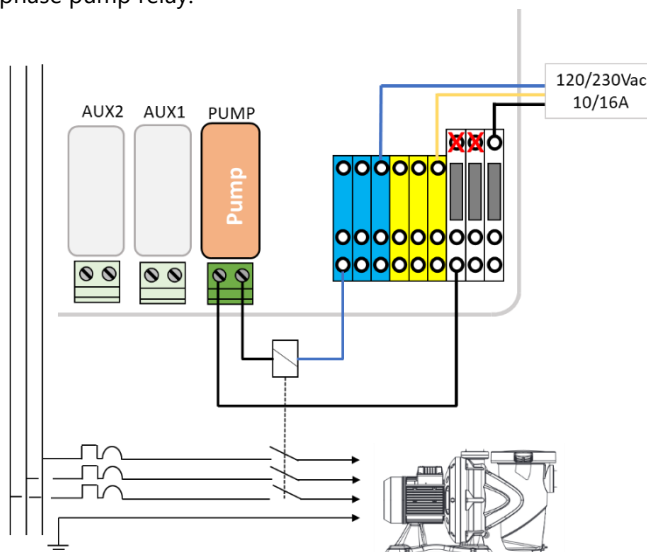

Figure 18 - Three-Phase Pump Connection.

3.4.5 Connecting a Variable Speed Pump

See the **VARIABLE SPEED PUMPS GUIDE** downloadable on our internet website www.poolcop.com in RESOURCES /DOWNLOADS section for compatibility, connection, control and programming.



WARNING:
 Never exceed the power ratings. Max Output 12VDC is 100mA. Max Output 24Vac is 450mA.
 Always conform to local installation norms and requirements.

3.4.5.1 Pentair IntelliFlo VSD/VSF (with IntelliComm or IntelliComm II drive)

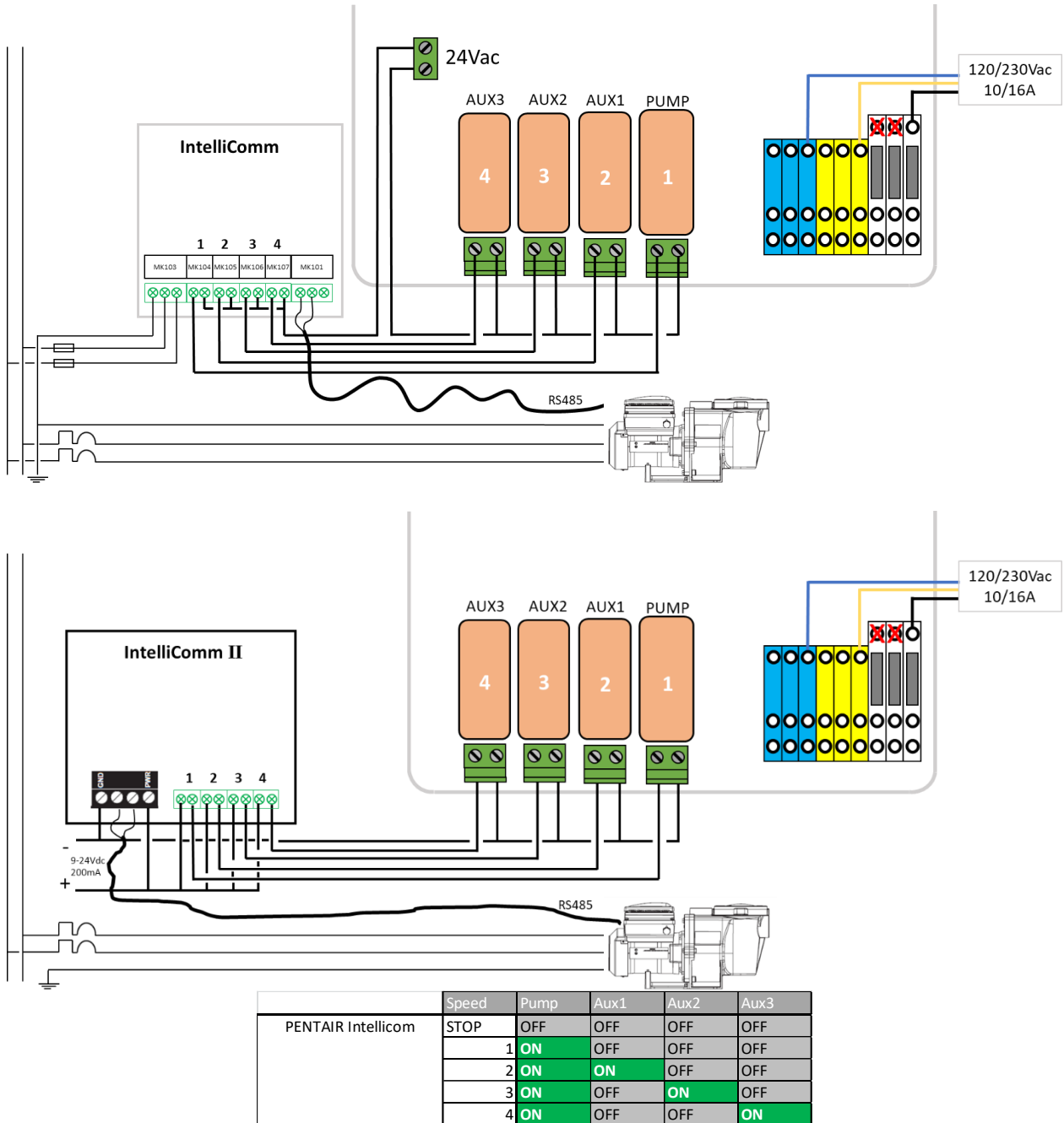
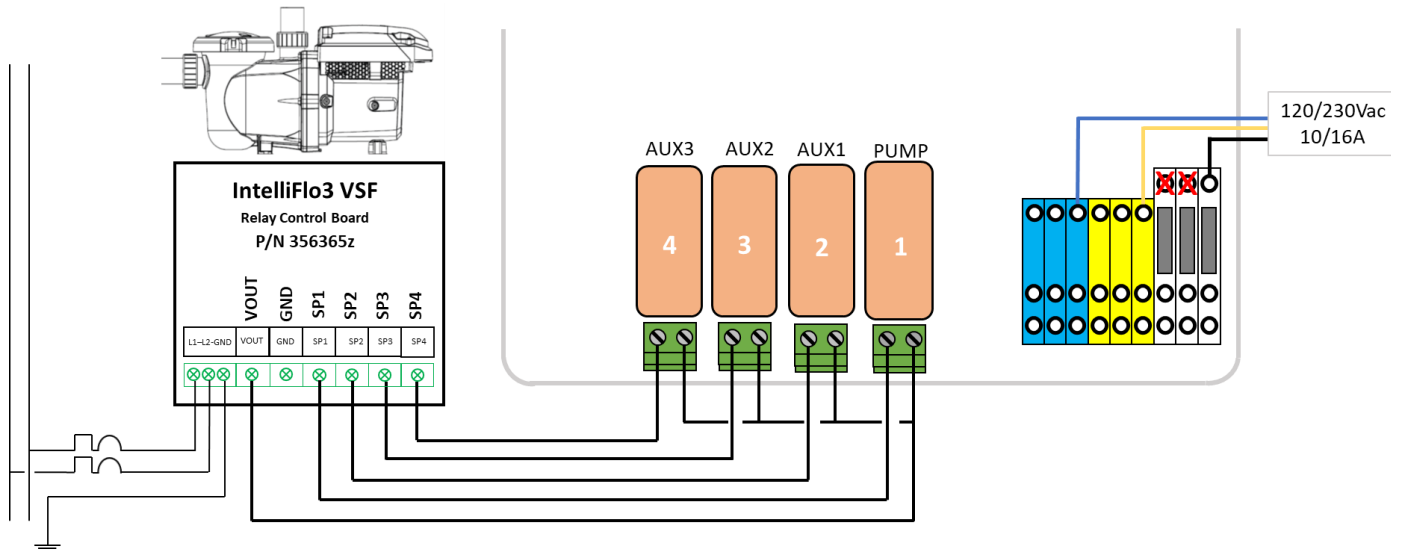

Figure 19 - Pentair IntelliFlo VSD/VSF with IntelliComm or IntelliComm II

3.4.5.2 Pentair IntelliFlo3 VSF



	Speed	Pump	Aux1	Aux2	Aux3
PENTAIR Intellicom	STOP	OFF	OFF	OFF	OFF
	1	ON	OFF	OFF	OFF
	2	ON	ON	OFF	OFF
	3	ON	OFF	ON	OFF
	4	ON	OFF	OFF	ON

Figure 20 - Pentair IntelliFlo3 VSF

3.4.5.3 Pentair SuperFlo VS/VS2

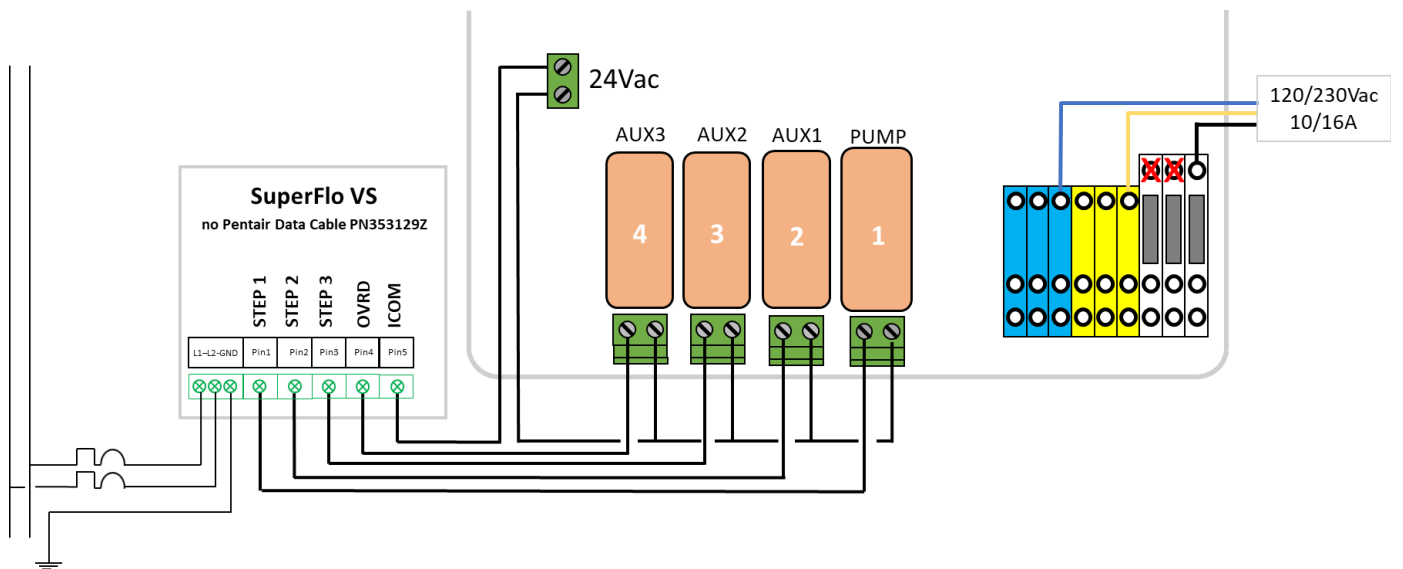

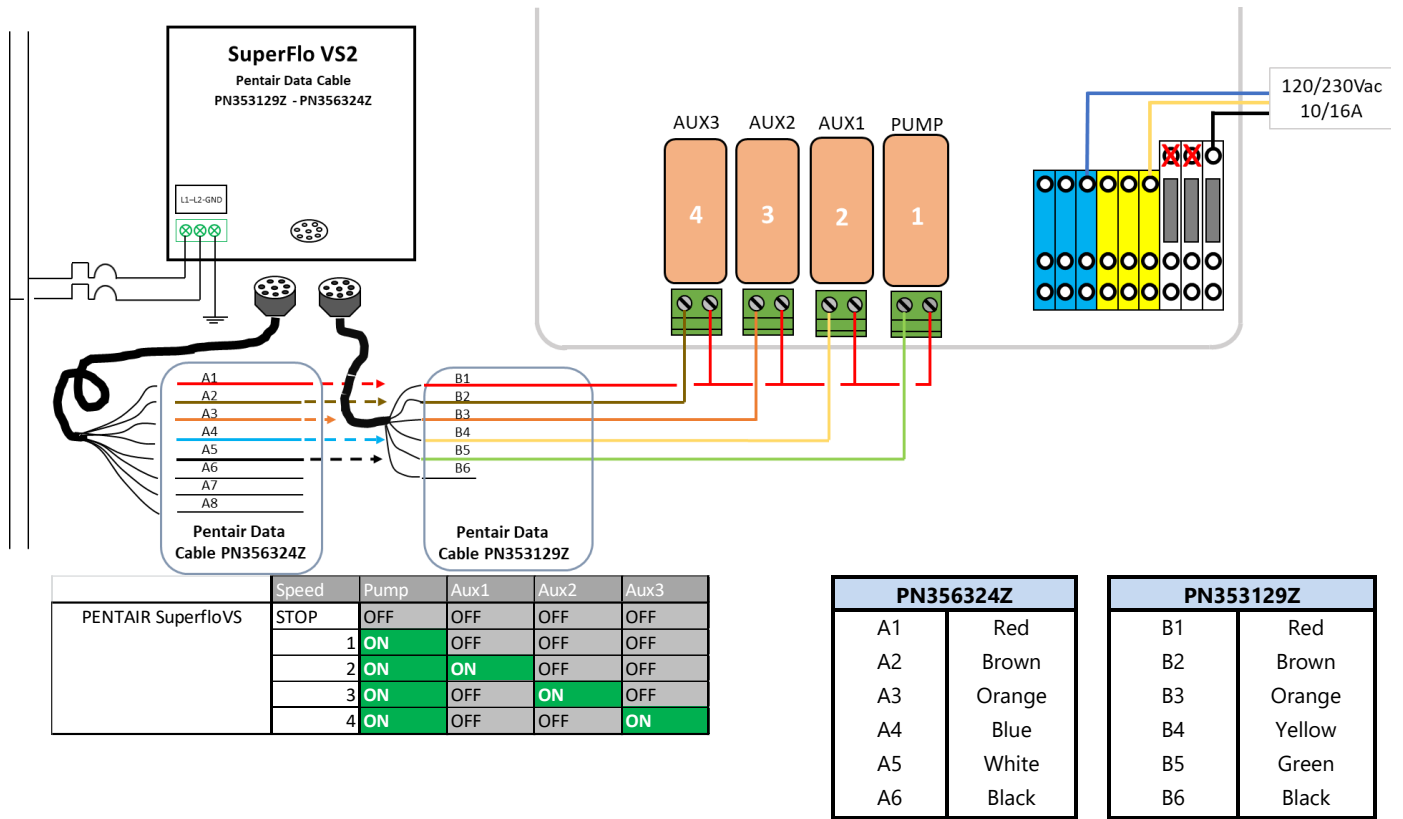

Figure 21 - Pentair SuperFlo VS/VS2

3.4.5.4 Hayward Eco Star

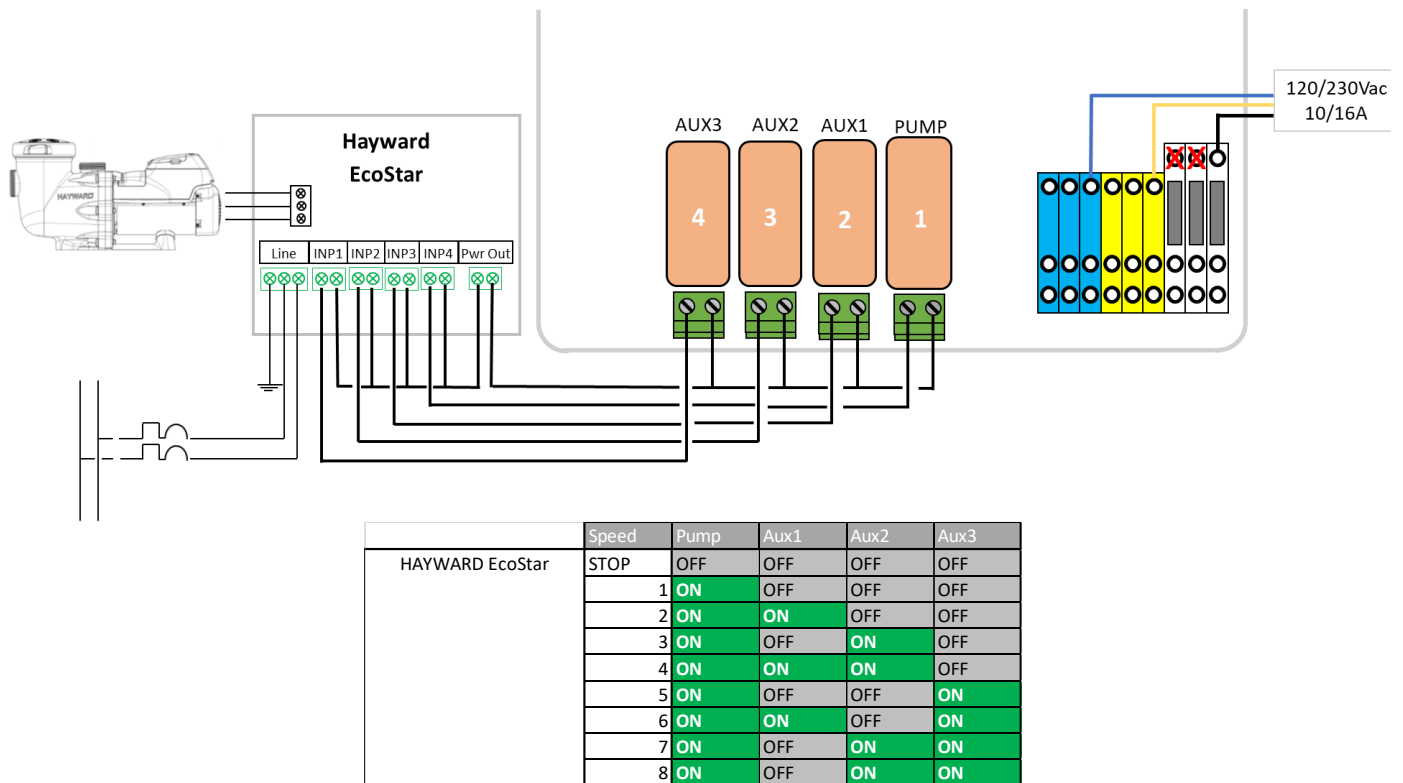

Figure 22 - Hayward Eco Star

3.4.5.5 Hayward VSTD Series

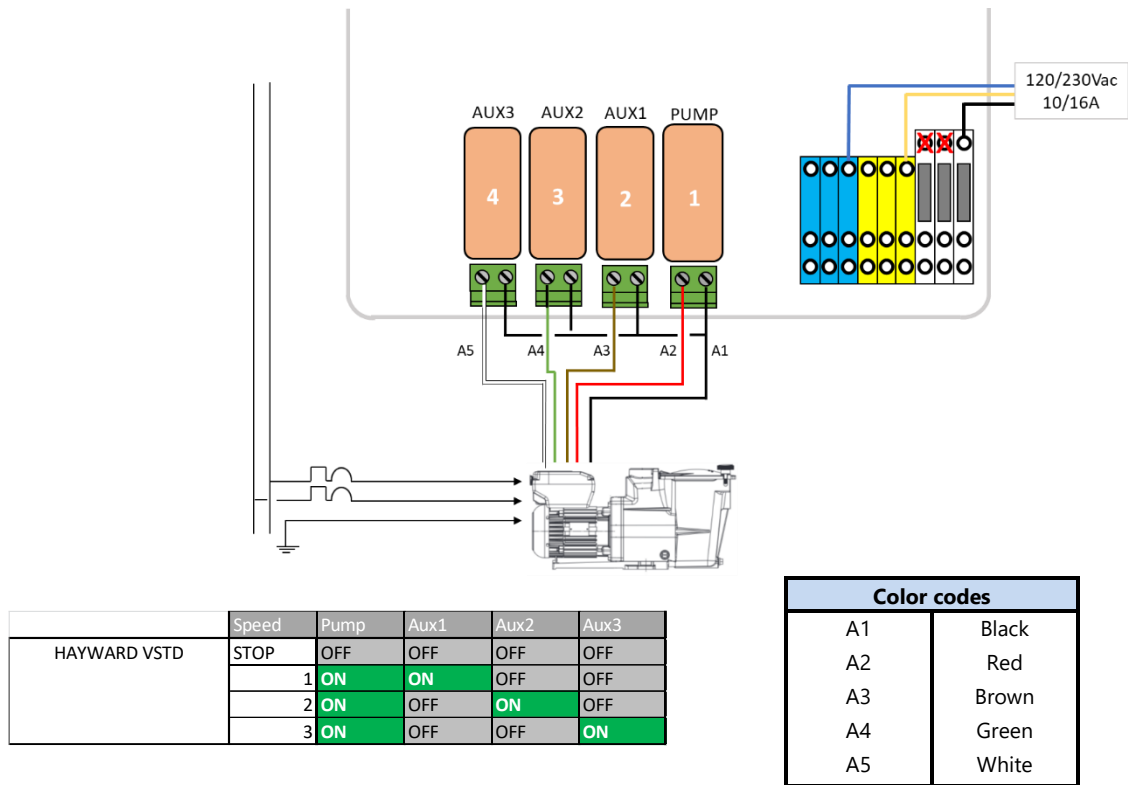

Figure 23 - Hayward VSTD Series

3.4.5.6 BADU Eco Touch-pro, ACIS VIPool MKB VS

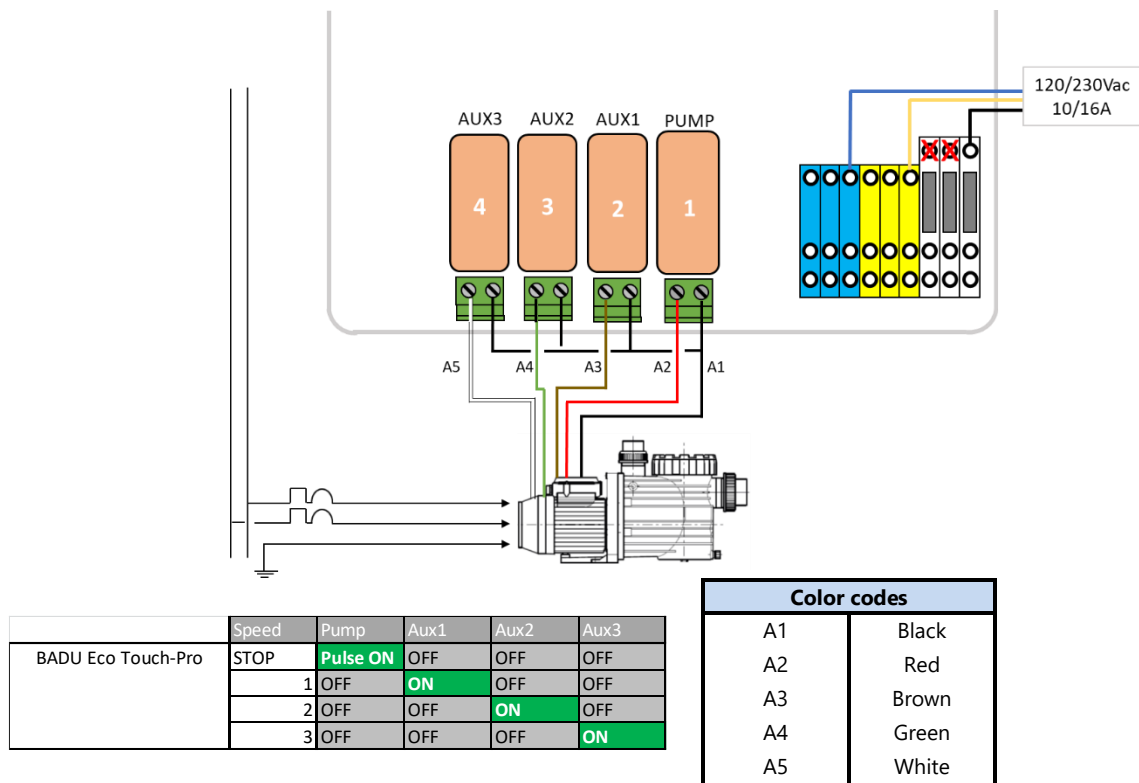

Figure 24 - BADU Eco Touch

3.4.5.7 BADU 90 Eco Motion

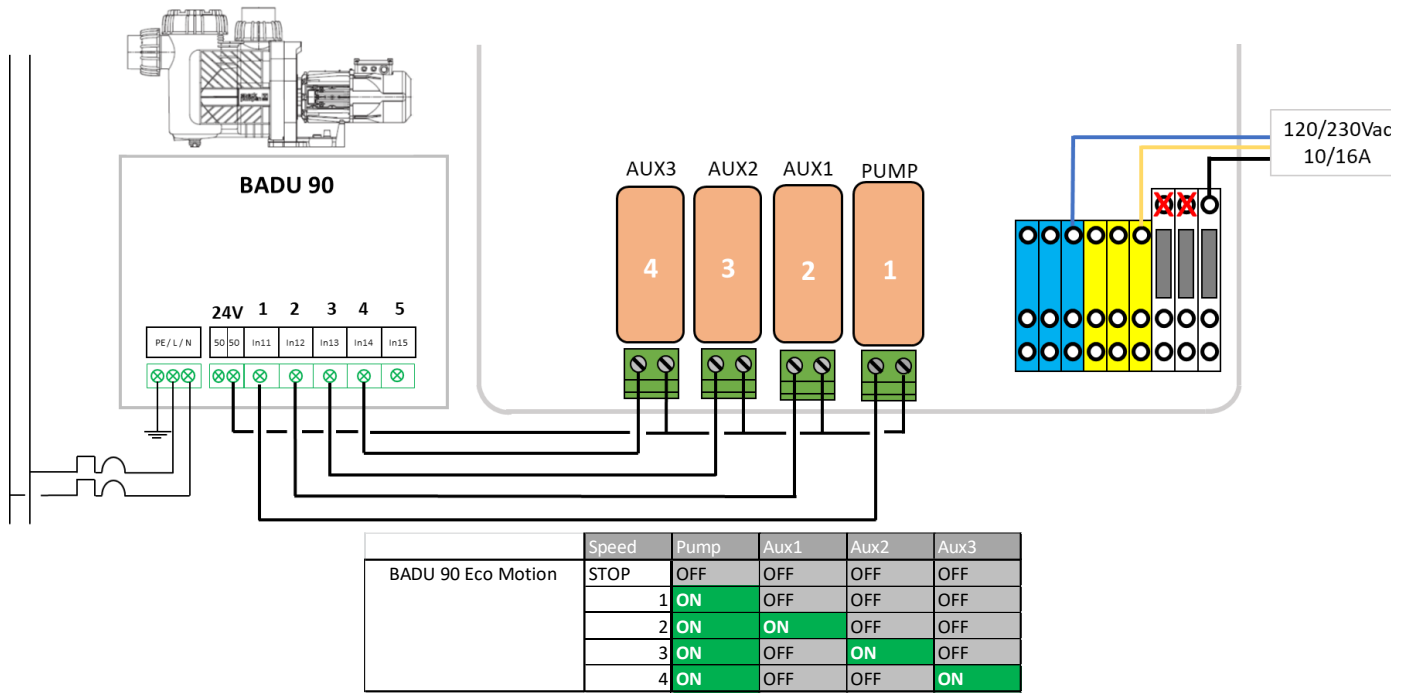

Figure 25 - Speck Badu Eco Motion

3.4.5.8 Zodiac FloPro VS

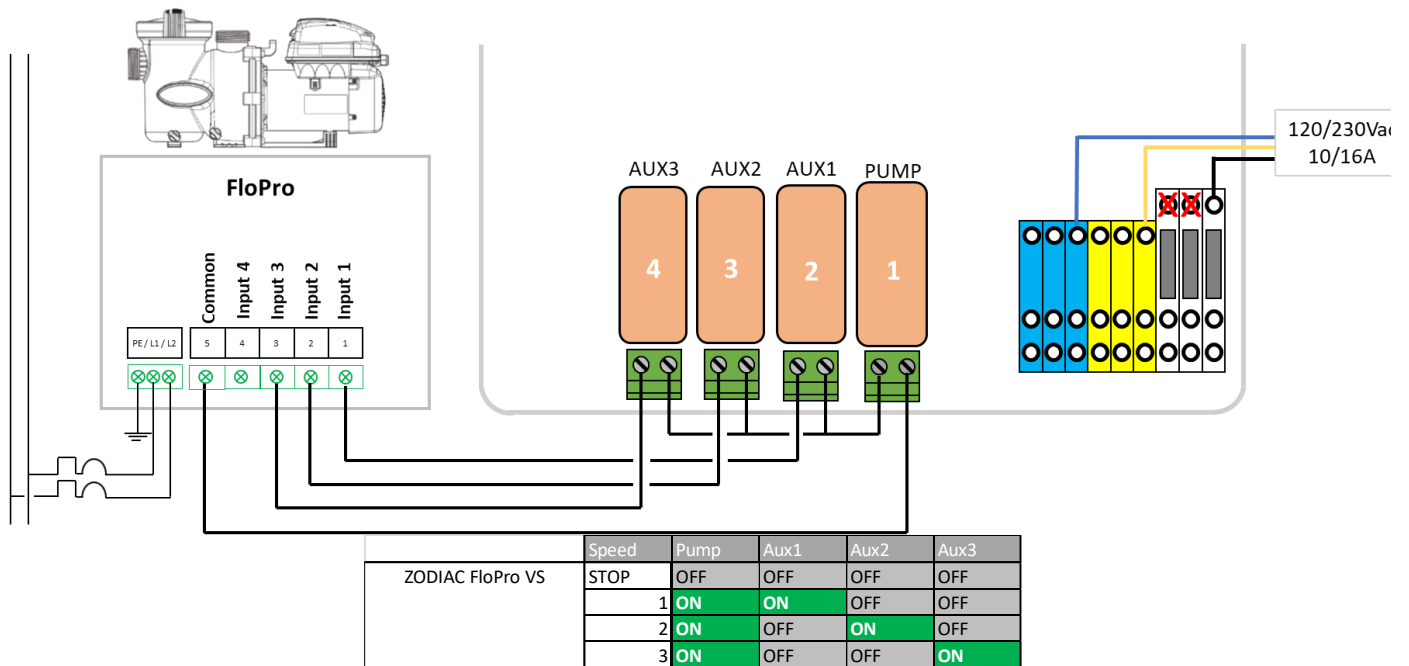
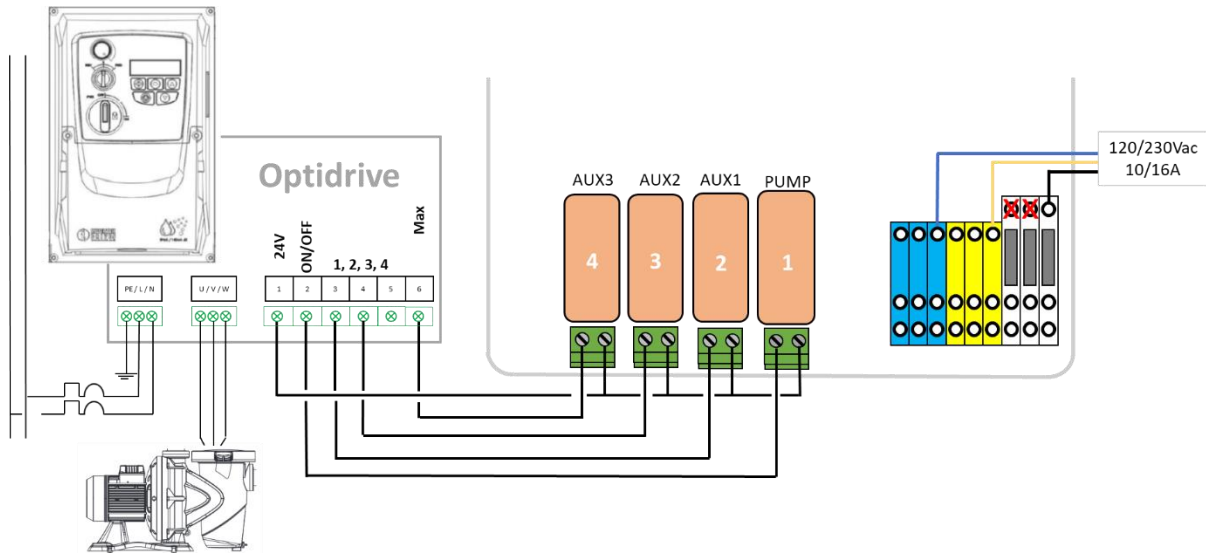

Figure 26 - Zodiac FloPro VS

3.4.5.9 Invertek Optidrive e² Inverter



	Speed	Pump	Aux1	Aux2	Aux3
INVERTEK OPTIDRIVE	STOP	OFF	OFF	OFF	OFF
	1	ON	OFF	OFF	OFF
	2	ON	ON	OFF	OFF
	3	ON	OFF	ON	OFF
	4	ON	ON	ON	OFF
	5	ON	OFF	OFF	ON

Figure 27 - Intertek Optidrive e2 Inverter

3.4.5.10 Binary Combination

This option is not related to a specific pump but can be used to control several mono speed pumps.

	Speed	Pump	Aux1	Aux2	Aux3
Binary Combination	STOP	OFF	OFF	OFF	OFF
	1	ON	OFF	OFF	OFF
	2	ON	ON	OFF	OFF
	3	ON	OFF	ON	OFF
	4	ON	ON	ON	OFF
	5	ON	OFF	OFF	ON
	6	ON	ON	OFF	ON
	7	ON	OFF	ON	ON
	8	ON	ON	ON	ON

Figure 28 - Binary Combination

3.4.5.11 Davey ProMaster VSD400

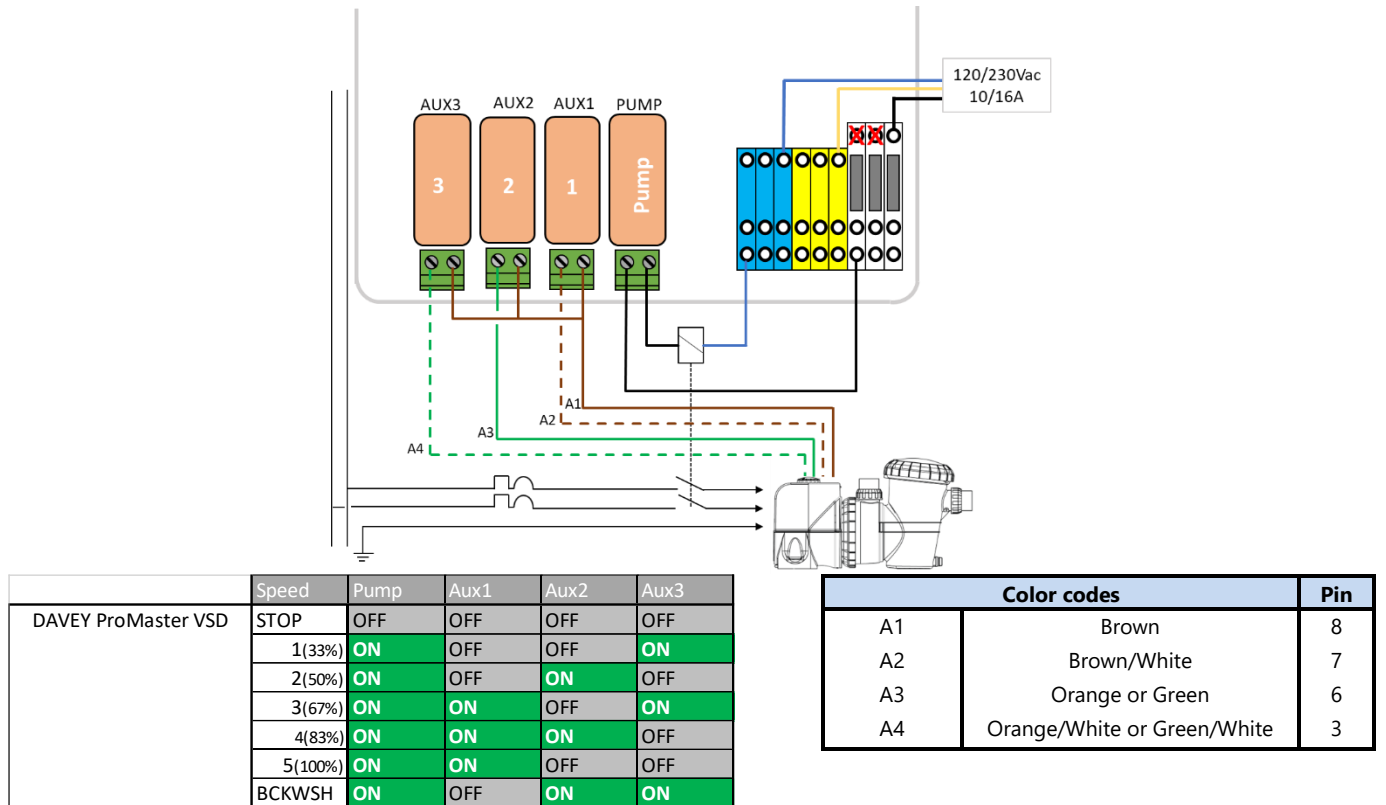

Figure 29 - Davey ProMaster VSD400

3.4.5.12 DAB E.SWIM-E.PRO

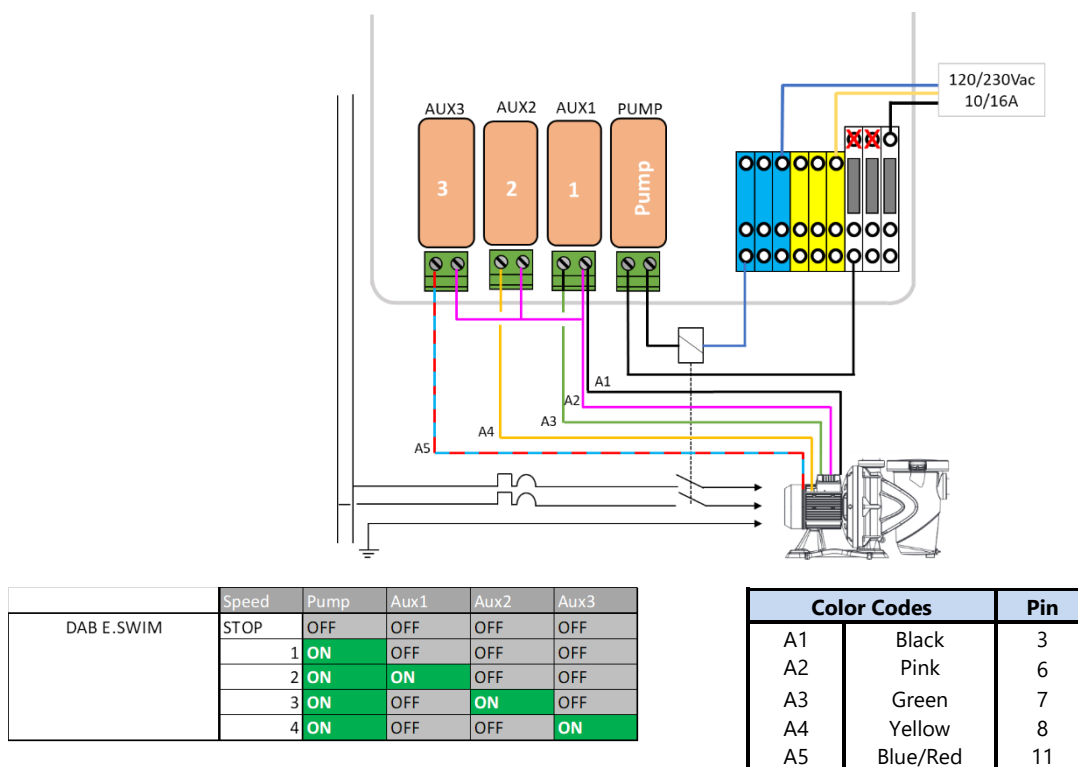

Figure 30 - DAB E.SWIM-E.PRO

3.4.5.13 AQUAGEM iSAVER+, Inverpro, Inverstar, ACIS Varipool, CF Vitalia VS

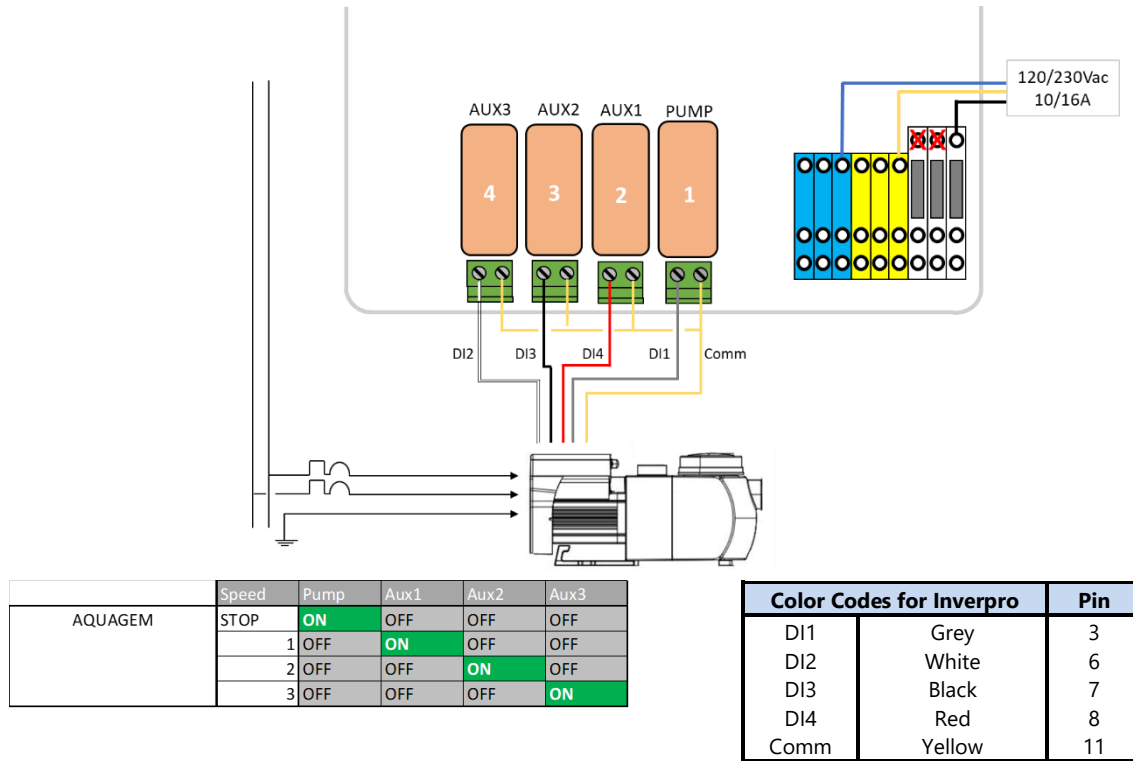

Figure 31 - AQUAGEM iSAVER+, Inverpro, Inverstar, ACIS Varipool, CF Vitalia VS

3.4.5.14 SACI [e]pool, [e]joy

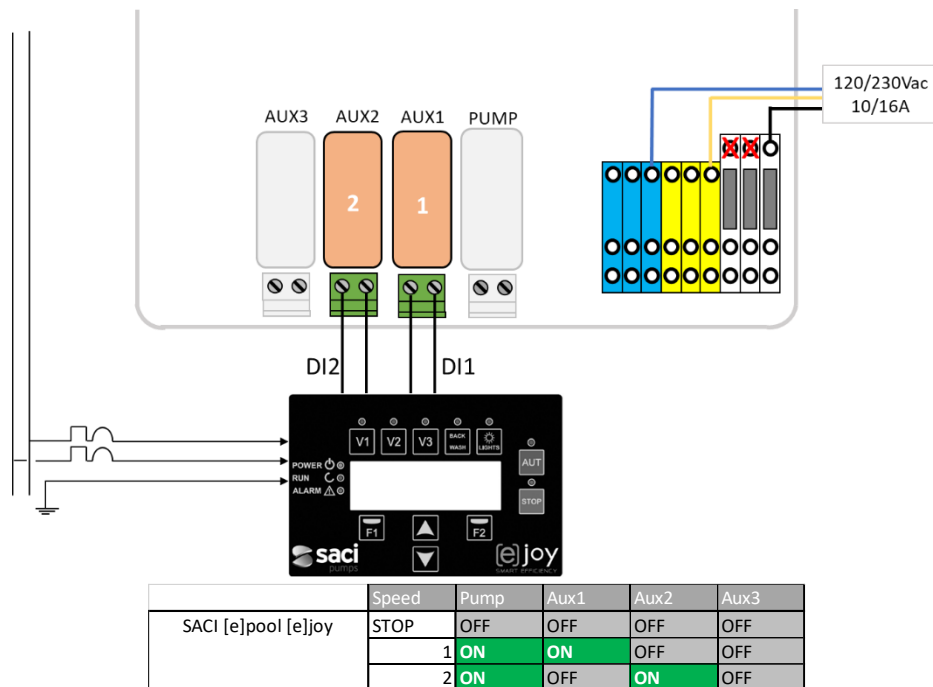
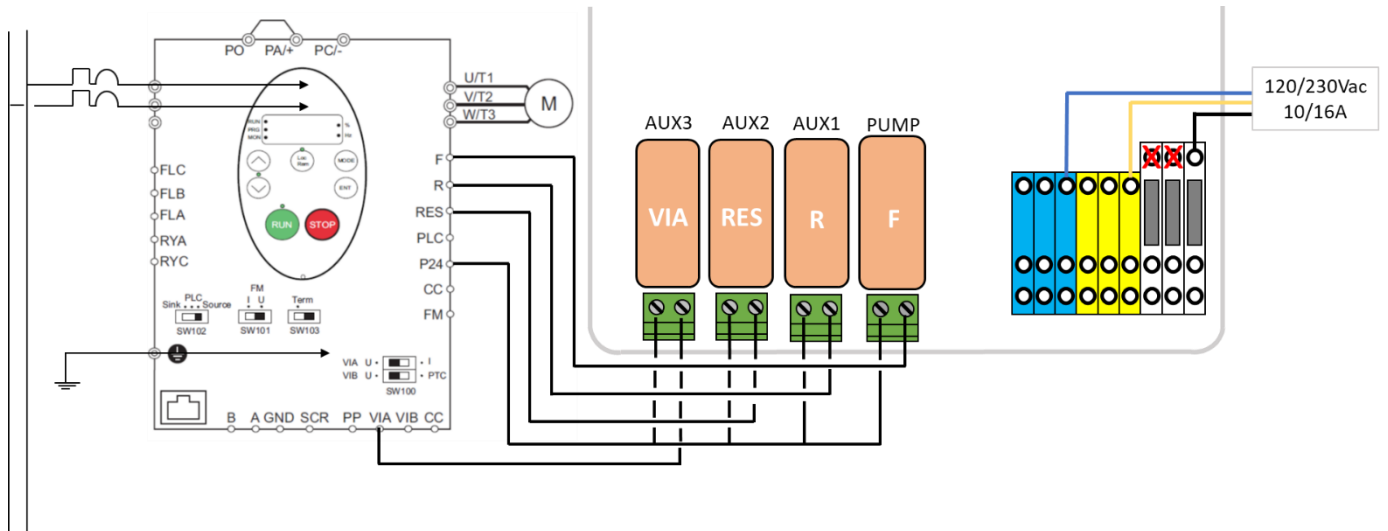

Figure 32 - SACI [e]pool, [e]joy

3.4.5.15 SCHNEIDER Altivar ATV212



	Speed	Pump	Aux1	Aux2	Aux3
SCHNEIDER ATV212	STOP	OFF	OFF	OFF	OFF
	1	ON	ON	OFF	OFF
	2	ON	OFF	ON	OFF
	3	ON	ON	ON	OFF
	4	ON	OFF	OFF	ON
	5	ON	ON	OFF	ON
	6	ON	OFF	ON	ON
	7	ON	ON	ON	ON

Figure 33 - SCHNEIDER Altivar ATV212

3.5 INSTALLING STANDARD FEATURES

3.5.1 Air Temperature Sensor

The optional Air Temperature Sensor measures outside air temperature, displays this on the screen, and is used for antifreeze protection if configured in the **POOL DATA** menu.

- Disconnect all electrical power to the pool and systems.
- Switch the equipment OFF and open the CCU.
- Route the sensor and cable via a compression gland to a location where external air temperature is representative of actual temperature to which the pool surface is exposed. Secure the sensor cable in an appropriate manner.
- Fit the Air Temperature Sensor to J27.

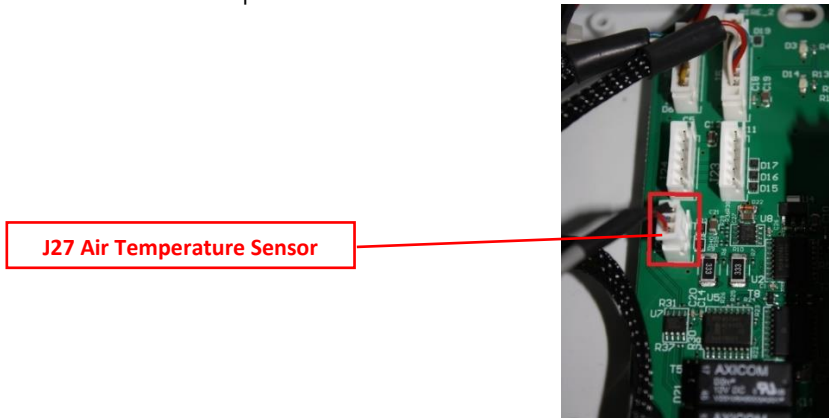

Figure 34 - Air Temperature Sensor on J27



CAUTION:

Keep a minimum distance of 10cm between the air temperature sensor cable and any 120V/230V power cable to avoid disturbance due to capacitive coupling.

- Close the CCU cover.
- Switch the equipment **ON**.
- Check the CCU main screen for air temperature display.

3.5.2 Connecting Auxiliary Relays

An auxiliary relay acts as a switch in the same way as the mechanical switch or timer:

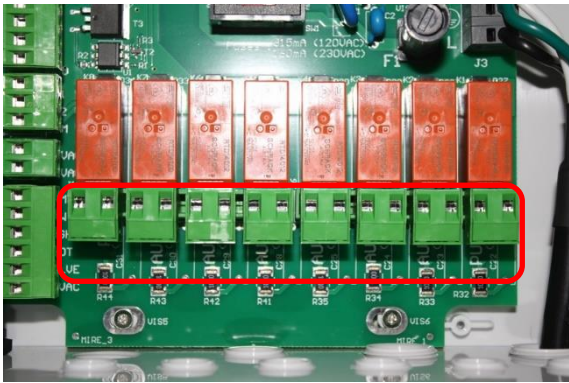

Relay Terminals in the CCU

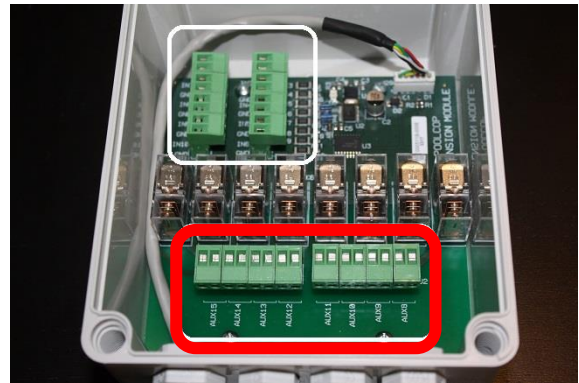

Relay Terminals in the XM8

Figure 35 - Auxiliary Relay Connection

- Auxiliary relays can control auxiliary pool equipment, such as lights, heating, pool cleaners, etc.
- Auxiliary **Aux7** is dedicated to pH Control.
- With ORP Control installed and configured, **Aux6** is dedicated to ORP Control.
- With XM8 and Pool Cover function installed, **Aux14** is dedicated to open cover, **Aux15** to close.
- With XM8 and JetStream function installed, **Aux13** is dedicated to JetStream pump control.

Each auxiliary relay has its own dedicated timer, programmed in the PoolCop **AUXILIARIES MENU**. Auxiliary relays can be given a default name or a custom name from the list available. Relays can be slaved to the pump.

3.5.2.1 Connection Instructions



WARNING:
Never exceed the power ratings.
Max Output 12VDC is 100mA. Max Output 24Vac is 450mA.
Always conform to local installation norms and requirements.

- Use multi-core cable to connect the auxiliary circuits to the auxiliary relays (Aux1 to Aux6) in the CCU.
- The auxiliary relay functions in the same manner as a mechanical timer.
- The wires should be connected in the applicable slots on connectors J6/J19 (CCU) or J1/J2(XM8) (Figure 35 - Auxiliary Relay Connection)

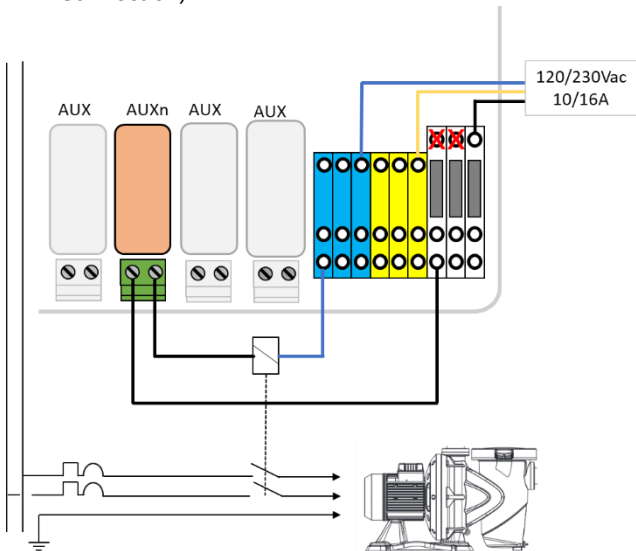

Figure 36 - Single Phase Auxiliary

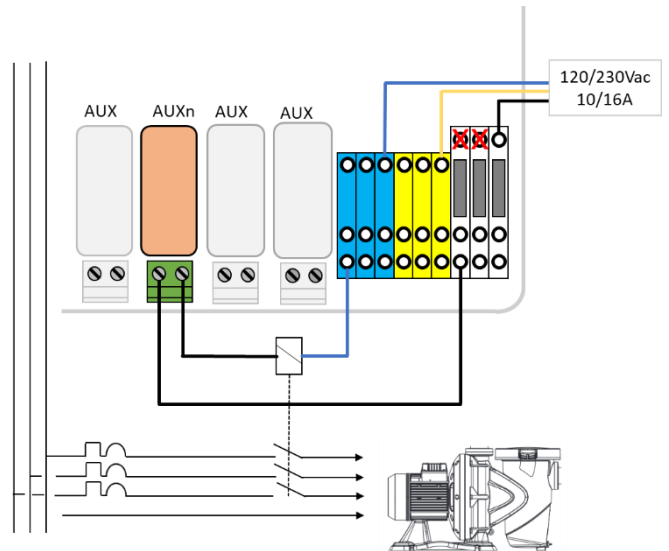

Figure 37 - Three-Phase Auxiliary Connection,

3.5.2.2 Relay Timer Programming

Each auxiliary relay can be programmed with one daily timer cycle. Auxiliary relays can be slaved to run only if filtration is running (see 5.3 Auxiliaries Menu)

3.5.3 Connecting Inputs

Several types of sensors and equipment can be connected to add functionality and trigger alerts. Inputs must be connected between the chosen input channel and the GND.



CAUTION:
Inputs are polarized with 5VDC.
Ensure that the signal connected to each input is potential free to avoid damage.

The Input can be assigned to any predefined functions with direct action (action when the contact is closed) or reverse action (action when the contact is open). Inputs must be potential free contacts. The configuration menu lets you select the role and direction of action of each entry.

The inputs are situated:

- In the CCU and are labelled IN1 and IN2; see Figure 38 - Connecting Inputs in .
- In the XM8 and are labelled IN3 to IN10; see Figure 39 - Connecting Inputs in XM8.

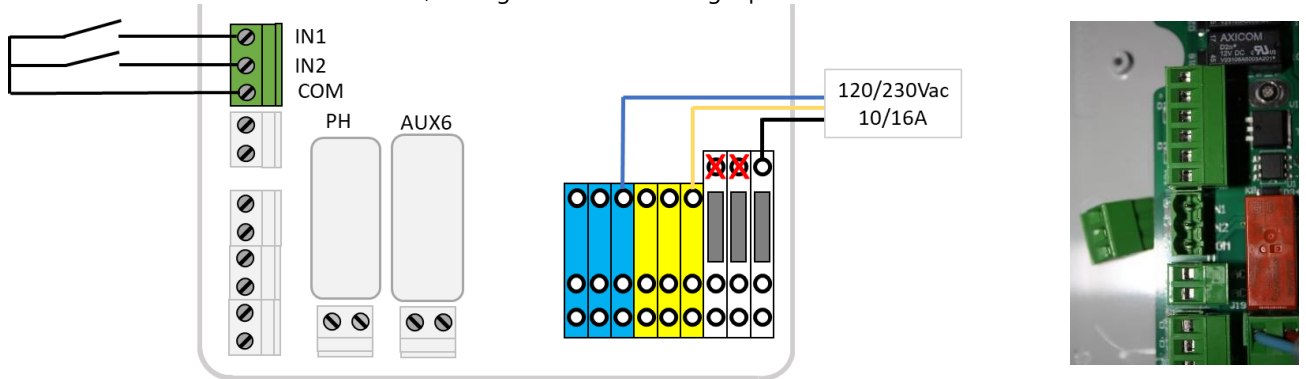

Figure 38 - Connecting Inputs in CCU

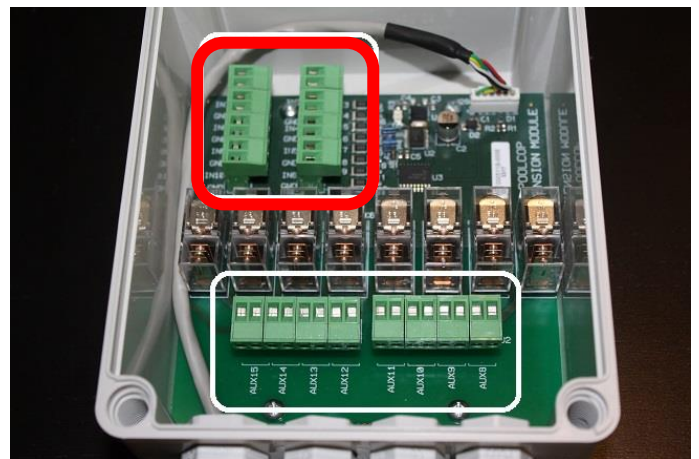
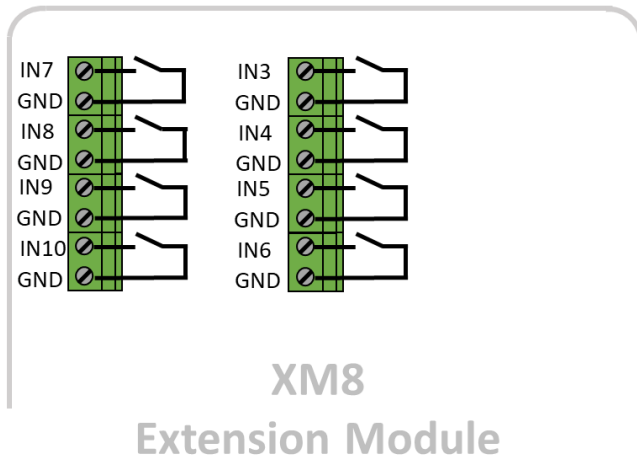

Figure 39 - Connecting Inputs in XM8

3.5.3.1 External Thermostat



NOTE:
An external thermostat is not required if the Air Temperature Sensor is installed.

Freezing risk can be detected by means of a properly installed and configured external thermostat if installing the Air Temperature Sensor is not possible. Generally, the temperature setting is in the range -5°C to +5°C (23 to 41°F), depending on location of the sensor. See the instruction manual for the thermostat for full details. The thermostat is connected to the selected input and to the GND. An Open or Closed circuit indicates a freezing risk; contact action is configured in programming.



Figure 40 - External Thermostat

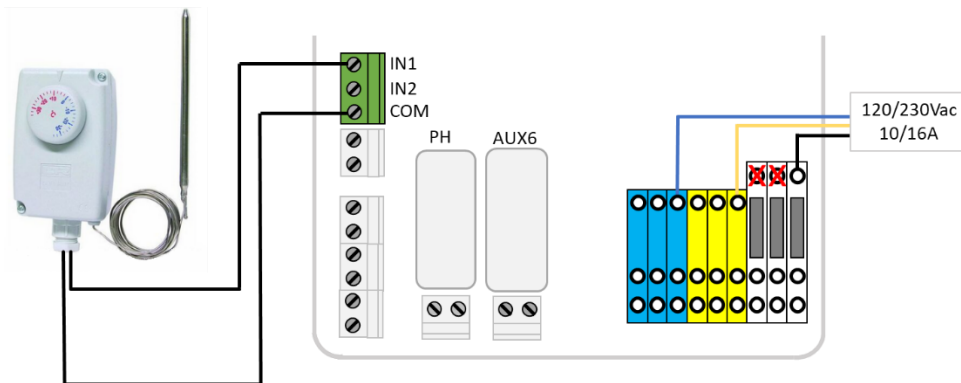

Figure 41 - Thermostat Connection



CAUTION:
The thermostat **does not guarantee** the prevention of freezing under all conditions. It may be necessary to protect equipment in the case of deep freezing and very low temperatures.

3.5.3.2 Detection of Low Consumables Level

Connected to an Input in the CCU and correctly configured, the detection indicates consumables level low, triggering an Alert. Set the low-level switch according to the manufacturer’s instructions.

Multiple suction wands or low-level sensors (or other low consumable detection circuits) for different consumables, can be connected in series. Any detector at low level will trigger the alert.



Figure 42 - Chemical Low Level Detection

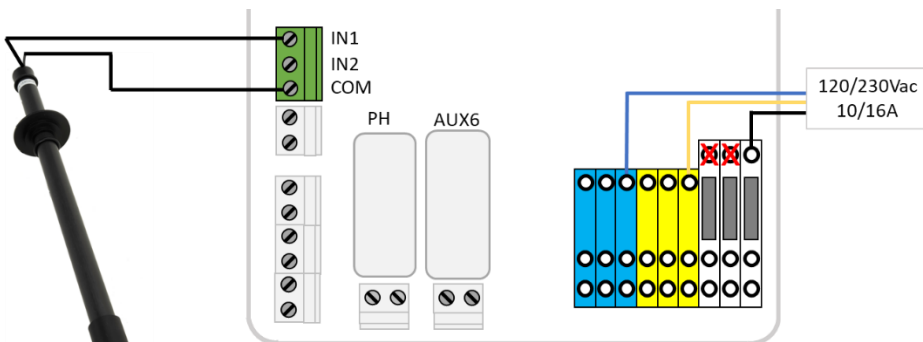

Figure 43 - Consumables Low Level Detection Connection

3.5.3.3 Pool Cover Detection

An external Pool Cover sensor can be connected to an Input to inform PoolCOP that the cover is in the closed position. Programming in the Pool Data menu then allows for adjustment of filtration duration and water treatments.

3.5.3.4 Salt System Attention Needed

A compatible saltwater chlorination system can use this Input configuration to alert conditions requiring intervention.

3.6 INSTALLING WATER TREATMENT

3.6.1 General

The equipment is compatible with all water treatments. There are no specific restrictions on use of any legally permitted swimming pool water treatment with equipment. Follow all manufacturer recommended guidelines to ensure safety, correct dosing and equipment life.

There are two types of sensors available, the sensors have the same dimensions and fit the same housing:

Treatment Option	Sensor Required	Sensor Reference
pH + liquid chlorine injection; chlorine or bromine tablets	pH+ORP Pt Sensor kit	SO4902
pH + saltwater system	pH+ORP Au Sensor kit	SO4903



WARNING

A flow sensing device should be properly installed and configured to secure chemicals dosing. If the flow sensing device is not added or not correctly configured and pipe is blocked, chemicals may build up in the pipes. Releasing the flow may create unsafe water chemistry conditions locally in the pool and may harm people.



WARNING:

Certain precautions must be taken **PRIOR** to installation of the sensor to ensure correct measurement and to prevent the possibility of damage: Install and test an electrical earth bonding in accordance with local regulations. Test the water for presence of metals (iron, zinc, copper) and use a metal sequesterate treatment in any case.

3.6.2 Installing the Water Condition Sensor

The water condition sensor has a supplied housing. Installation of the different type of pH+ORP sensors is identical.



Figure 44 - pH+ORP Sensor with Transport Cap



Figure 45 - pH+ORP Sensor and Housing



Figure 46 - Sensor Housing plug



Figure 47 - Sensor connection

- Verify that the pump circuit breaker is **OFF**, and/or use **SERVICE MODE**, and/or set all pump timers to 00:00 in **FILTRATION MODES** menu, with filtration timer mode to **STOPPED**.
- Close all valves; ensure that all possible water supply is cut off and depressurize the circuit.



CAUTION:

Removing the sensor from piping whilst there is pressure or a head of water in the circuit can cause water to flood and damage equipment.

- Remove the blanking plug in the sensor housing.
- Fit the sensor housing, with O-Ring.
- Remove the liquid filled transport cap from the sensor.



CAUTION:

The transport cap must be removed prior to fitting the sensor. Fitting the sensor without removing the transport cap will result in erroneous pH and ORP readings and chemical regulation.

- Check/adjust the grab ring, the grab ring must be between 25-30mm (0.98-1.18") from the sensor shoulder.

- The blue (SO4902) or white (SO4903) band ensures spacing between the securing nut and the sensor shoulder.



Figure 48 - SO4902 Spacing, Grab Ring Adjustment



Figure 49 - SO4903 Spacing, Grab Ring Adjustment

- Check/adjust compression ring and O-Ring accordingly.
- Fully insert the sensor into the housing, and secure with the nut.
- Finger tighten the securing nut.



CAUTION:

**Do not over-tighten as the electrode is a sensitive device.
Ensure that the cap is sufficiently secure to retain the sensor in place under water pressure.**

- Remove the plastic cover from the PCB's.
Connect the sensor wire plug to JP6 onto the Connection SE Data PCB.

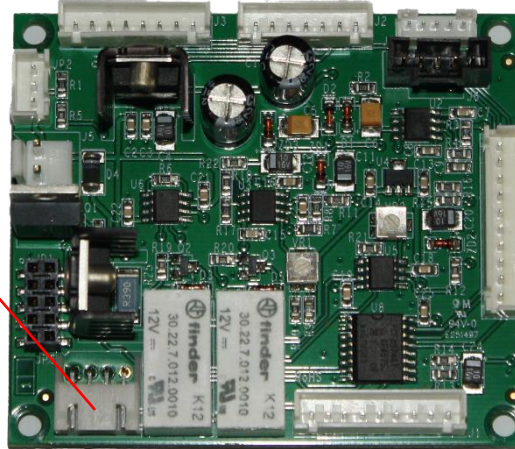

Figure 50 - Connecting pH/ORP Sensor

- Replace and secure the plastic cover.
- Open valves and reconnect water supply, whilst checking for leaks.
- Reconnect the pump circuit breaker.
- Reset the filtration timers and mode as required.
- Start the pump from **MANUAL CONTROL** menu and check for leaks.
- Leave the pump running or switch the pump from **MANUAL CONTROL** menu, as required.

3.6.3 pH Control



WEAR HAND PROTECTION:

Always wear correct chemical resistant hand protection when handling chemicals.



EYE PROTECTION:

Always wear correct eye protection when handling chemicals.

pH control requires the pH+ORP sensor.

When filtration cycles are used (all filtration modes except **24/24** use daily cycles), pH is automatically measured 15 minutes after the end of each filtration cycle. The updated pH is displayed immediately. If only one filtration cycle is set, the pH is measured automatically once per day; if both filtration timers are set, pH is measured automatically twice per day.

When filtration runs in **24/24** filtration mode, pH is controlled every hour when disinfection is in observation phase.

pH can be measured at any time by first stopping the filtration pump, and then selecting **MEASURE PH** in **MAINTENANCE** menu.

pH information is used for pH control functions and Alerts. However, independent pH control systems can be installed with the equipment. In this case equipment can be used to measure pH and trigger Alerts if the pH is out of the normal range.

3.6.3.1 pH Sensor Calibration

The sensor can be calibrated using pH buffer fluids or liquids of known pH-

3.6.3.2 Information and Guidance

The equipment has proportional- integral pH Control. An ON/OFF feeder pump (peristaltic or electromagnetic) and installation kit is required. pH Control logic and safety:

- With filtration cycles:
 - The dosing is executed once at the beginning of each filtration. It is recommended to program two daily filtration cycles, to enable two dosing periods per day. **Filtration should be stopped for at least 30minutes between 2 filtration cycles to allow pH algorithm to work properly.**
 - Whatever are the settings, maximum dosing time is **30 minutes per filtration** cycle (60 minutes per day if the recommendation for two cycles is respected).
- In **24/24** filtration mode:
 - The reading is done **every hour**, when disinfection is in observation phase.
 - The dosing is executed just after reading. **Duration is limited to 15 minutes** maximum per injection.
 - Whatever are the settings, maximum dosing time is **240 minutes per day.**
- Proportional-integral control logic allows for very safe operations and avoids risks of overdosing.
- Setting the maximum dosing time is a way to adjust control power. Maximum dosing must be adjusted in accordance with pool volume, water alkalinity and the feeder pump flow rate to provide best results.
- The pH Control relay AUX 7 is protected, and injection will be stopped in the case of loss of flow, loss of pressure, pump off securities, etc. for safety.
- An alert will be generated if pH is not in the defined range. pH control will continue to operate normally.
- An alert will be generated if pH does not change after 5 successive injections to indicate that the control is ineffective.
- As a security, if the measured pH is out of limits (lower than 6.0 or higher than 9.5), pH control is stopped. An Alert message is displayed prompting for water balance.



NOTE:

As a security, if the measured pH is out of limits pH control is stopped.

- As soon as the pH re-enters the range 6.0 to 9.5, injection may restart.

3.6.3.3 Installing the Feeder Pump

- Install the feeder pump, associated suction and injection pipes and connectors as per the feeder pump installation manual.
- Ensure that the correct liquid consumable pH- or pH+ is installed and secured.
- Route the power supply for the feeder pump via an external Contactor.
- The contactor will be operated by AUX 7 in the CCU.
- Connect the feeder pump to the mains power supply as per the pump installation manual, ensuring electrical protection and conformity.

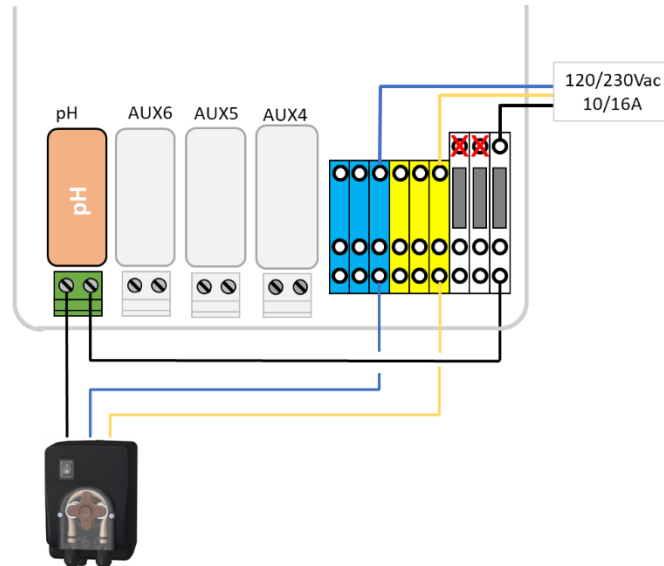

Figure 51 – 230Vac pH Feeder Pump Connection

- Test and prime the feeder pump:
In **WATER AND TREATMENT, PH CONTROL**, select priming **ON**.

3.6.3.4 pH Control Programming

- See 5.4.2.

3.6.3.5 Activating pH Control

- In the **MAINTENANCE** menu, command the equipment to **MEASURE PH**.

3.6.4 Disinfection



WEAR HAND PROTECTION:

Always wear correct chemical resistant hand protection when handling chemicals.



EYE PROTECTION:

Always wear correct eye protection when handling chemicals.

The equipment is compatible with all types of water disinfection. Disinfection can be with or without chemicals.

3.6.4.1 Disinfection Control

3.6.4.1.1 Controlled by ORP

ORP control is available for controlled disinfection. A sensor is required to perform the control. The water condition sensor type varies, depending on the chemical method used for treatment.

Treatment Option	Sensor Required	Sensor Reference
pH + liquid chlorine injection; chlorine or bromine tablets	pH+ORP Pt Sensor kit	SO4902
pH + salt water system	pH+ORP Au Sensor kit	SO4903



NOTE:

ORP measurement and control is not compatible with copper/silver ionization.

- pH+ORP sensor is required, correctly installed as per 3.6.2 Installing the Water Condition Sensor.
- Dosing is only commanded during programmed filtration cycles. Dosing will start 30 minutes after start of a filtration cycle.
- Proportional-integral control logic allows for very safe operations and avoids risks of overdosing.
- If "chlorine" or "bromine" disinfection algorithm is chosen, maximum possible time assuming filtration is running continuously will be **11 hours 50 minutes**.
- If "salt" (for saltwater chlorinator) disinfection algorithm is chosen, maximum possible time assuming filtration is running continuously will be **19 hours 40 minutes**.
- The relay AUX 6 is protected and injection will be stopped in case of loss of flow, loss of pressure, pump off securities, etc. for safety.
- If required, disinfection can be stopped due to low water temperature (useful to ensure chlorinator cell life).
- An alert that the control is inefficient will be generated if:
 - ORP does not increase after 20 successive injections (algorithm "Chlorine" or "Bromine").
 - ORP does not increase after 5 successive production cycles (algorithm "Salt").



NOTE:

As a security, if the measured ORP is out of limits (lower than 100mV or higher than 990mV) for more than approximately 40 minutes, ORP control is stopped and an Alert is displayed.

- As soon as the ORP re-enters the range 100mV to 990mV, injection may restart.
- Configure ORP control in the **WATER AND TREATMENT** menu, program **ORP CONTROL** (See 5.4.3).

3.6.4.1.2 Dosage controlled by volume and temperature

- This function adjusts disinfectant volume injected based on:
 - Dosing pump flow rate.
 - Pool volume.
 - Water temperature.
- Targeted dosage is 6ml/m³/day.
- Dosage is progressively increased to twice the initial amount as water temperature rises from 22°C to 30°C (71.6°F to 86°F).
- An extra setting will allow to reduce by 50% or increase by 50% to take pool environment into account.
- The dosing relay is protected (pump off securities, etc.) for safety. For example, in case of priming loss, injection will be stopped.
- Configure Remnant control in the **WATER AND TREATMENT** menu, program **REMNANT INJECTION** (See 5.4.4).

3.6.4.2 Means of Disinfection

3.6.4.2.1 Chemical Injection by Feeder Pump or Other Equipment

- Install the feeder pump or other equipment, associated suction and injection pipes and connectors as per the equipment installation manual.
- Ensure that the correct consumable is installed and secured.
- Route the power supply for the equipment via an external contactor. The contactor will be operated by the chosen auxiliary output in the CCU.
- Connect the equipment to the mains power supply as per the equipment installation manual, ensuring adequate electrical protection and conformity.



NOTE:

If injection is controlled by ORP sensor, the feeder pump must be controlled by Aux 6.



NOTE:

If injection is controlled by temperature / volume (remnant) any available Aux can be used.

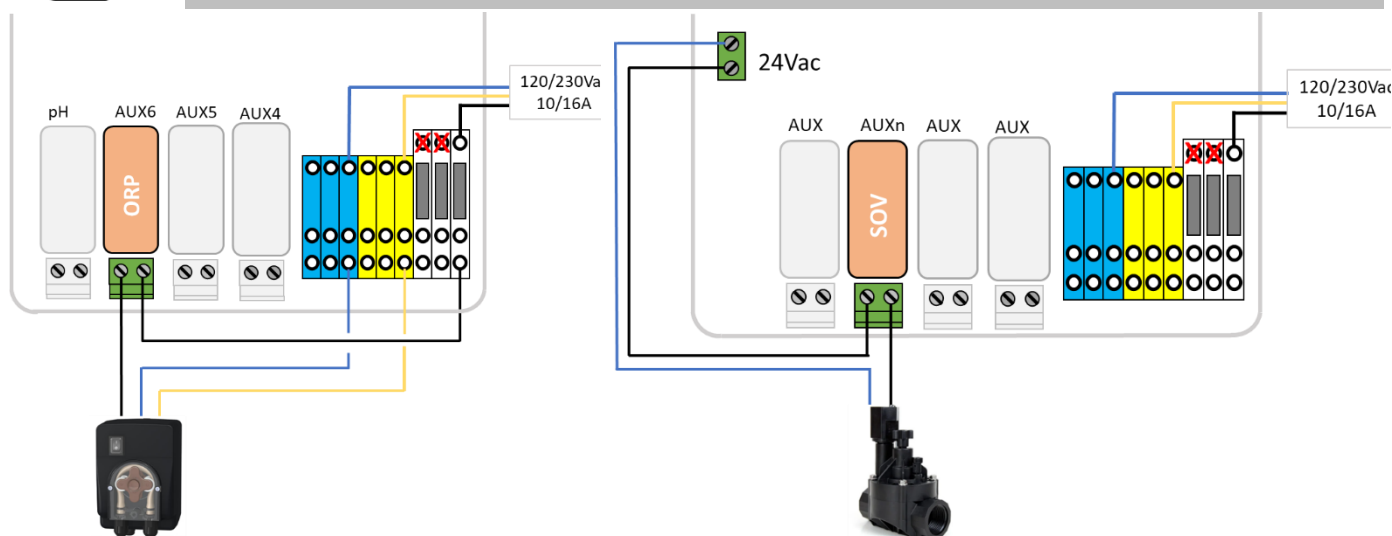

Figure 52 - Connecting 230Vac Feeder Pump or 24Vac solenoid valve for disinfection

- Test and prime the feeder pump, if applicable:
 - In **MANUAL CONTROL** menu, select the respective **AUX** to **ON**; the equipment or pump must run.
 - Or in **WATER AND TREATMENT, ORP CONTROL**, select priming **ON**.

3.6.4.2.2 Salt Water Chlorination

A correctly specified saltwater chlorination system and installation kit is required. When saltwater chlorination is used for treatment, regular water analysis will be carried out to ensure that salt consumables and free chlorine levels remain within the required limits. See the manufacturer's guidelines and instructions for use.

- Install the saltwater chlorinator and associated plumbing as per the manufacturer's instruction and installation manual.
- Ensure that the correct quantity of salt consumable is added in the correct manner to the pool water.
- Route the power supply for the salt chlorinator via a via an external Contactor. The contactor will be operated by the AUX 6 in the CCU.
- Connect the salt chlorinator to the mains power supply as per the manufacturer's installation manual, ensuring adequate electrical protection and conformity.
- If the chlorinator is compatible, an Input can be used for LOW SALT and other messages (see 3.5.3).

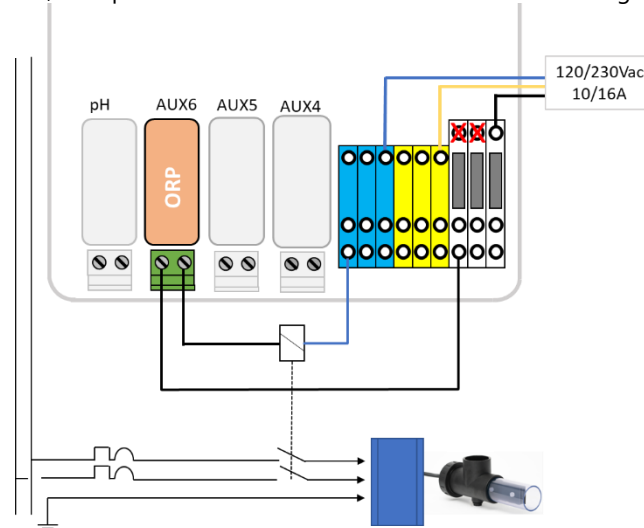

Figure 53 - Salt System Connection,

- Testing the saltwater chlorinator power supply:
 - Select the filtration to **ON** (the saltwater chlorinator requires water flow for proper operation).
 - Set the water supply valves as per the saltwater chlorinator operating instructions.
 - In **WATER AND TREATMENT, ORP CONTROL**, select priming **ON**.
 - The chlorinator must be powered.

See the saltwater chlorinator instruction manual for correct settings and running time for the pool.

3.6.4.2.3 Salt Water Chlorination with PoolCOP Ocean

PoolCOP Ocean is a dedicated saltwater Chlorinator optimized and controlled by PoolCOP.

When saltwater chlorination is used for treatment, regular water analysis will be carried out to ensure that salt consumables and free chlorine levels remain within the required limits.

See the **PoolCOP Ocean Guide** for information and guidance.

- Install the saltwater chlorinator and associated plumbing as per installation manual.
- Ensure that the correct quantity of salt consumable is added in the correct manner to the pool water.
- Connect the salt chlorinator to PoolCOP as per installation guide.
- Testing the PoolCOP Ocean control:
 - Turn power **ON** on PoolCOP Ocean.
 - Select the filtration to **ON** (the saltwater chlorinator requires water flow for proper operation).
 - Set the water supply valves as per the saltwater chlorinator operating instructions.
 - In **WATER AND TREATMENT, ORP CONTROL**, select **Disinfection=Ocean**.
 - In **WATER AND TREATMENT, ORP CONTROL**, select priming **ON**.
 - The chlorinator must produce.

3.6.5 Free Available Chlorine Sensor

The sensor allows to get the Free Available Chlorine value from the water sample going through the sampling chamber.

Free Available Chlorine values in ppm will be reported on the FAC Data menu, and Low and High Alerts can be set.

See the **Free Available Chlorine Sensor Installer and User Manual** for information and guidance.

3.7 INSTALLING OPTIONS

Various equipment options are available. These serve to increase autonomy and enhance functionality.

3.7.1 Water Level Control

Automatic water level control functionality is integrated. In order to benefit from this feature, the optional water level sensor and valve kit is required. After installation, configure Water Level Control in the Configuration menu (see 5.4.1).

When filtration cycles are used, water level is checked and controlled only when **filtration pump is stopped**. Refill will start when level is below setpoint and stop at setpoint or if maximum adjustable refill time is reached.

When using **24/24** filtration mode, level is checked and control every 20 minutes outside disinfection dosing periods. Water refill may start immediately but refill will be paused after 30 minutes. If water level is not at setpoint at this moment, refill will restart in the next 20 minutes. Several refill periods may be used to get to the setpoint. The maximum adjustable refill time is still in place to protect against leaks.

At the end of a filter cleaning, the water level is checked and readjusted (if refill is possible). To take into account overflow pools and possible level fluctuations in the buffer tank, the refill action can be repeated up to 20 times, leaving a 20-second delay between each level measurement. Repetitions stop as soon as the level stays at its set point.

When ready to commence the installation, the installer must:

- Disconnect all electrical power to the pool and systems.
- Close all valves, and if necessary, block all inlets to and outlets to/from the pool.

3.7.1.1 Installing the Water Line Version, with 4 Terminals

- Secure the water level sensor (using stainless steel self-tapping screws, or appropriate adhesive) at the correct height on the inside of the skimmer or on the waterline.
- If the level sensor is fitted in the skimmer, make sure that the skimmer basket and lid can easily be removed and replaced without damaging the sensor or cable.
- Normal water level must be between WL (HIGH) and WL (LOW).
- WL (HIGH) **must be below pool overflow level** and at an appropriate level with regards to the skimmer.
- WL (PROT) is the **V.HIGH** level, at maximum pool water level.

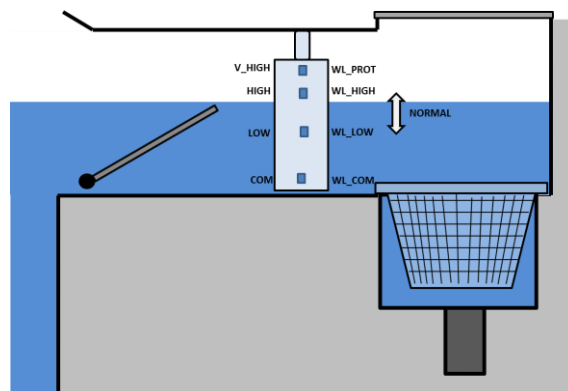

Figure 54 - Water Line Level Sensor

<u>PCB Label</u>	<u>TYPICAL Color</u>	<u>ACTUAL Color</u>
COM	Yellow	
LOW	Blue	
HIGH	Red	
PROT	Green	

Table 2 Water Line Version 4 Terminals, Cable and Connection

3.7.1.2 Installing the Buffer Tank Version, with 4 Sensors (Infinity Pools)

The 4 sensors are identical, with the same color cable.
Add tags/labels prior to installation to identify the correct cable and sensor.

- Check that the pool water level is correct and that the buffer tank level is correct.
- Secure the 4 water level sensors at the correct respective heights in the buffer tank.
- Normal tank level must be between WL (HIGH) and WL (LOW)
- WL (HIGH) **must be below tank overflow level.**
- WL (PROT) is the **V.HIGH** level, at maximum tank water level.

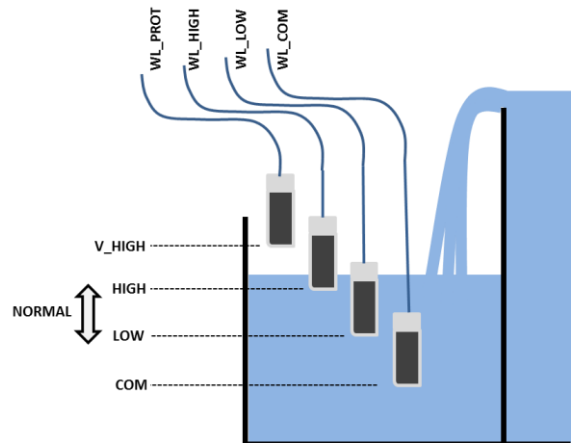

Figure 55 - Buffer Tank Water Level Sensors

PCB Label	Cable Color	Tag on Sensor
COM	Blue	
LOW	Blue	
HIGH	Blue	
PROT	Blue	

Table 3 Buffer Tank Version, with 4 sensors

3.7.1.3 Connecting the Water Level Sensors

- Before installing the water level sensor, check the colors corresponding to each terminal using a multi-meter.
- Ensure that the terminals are clean and free of any insulating film or grease.
- Route the wire from the level sensor to the CCU. A conduit will be used to protect the cable.
- Switch the CCU **OFF** and open the CCU.
- Feed the cable through a compression gland into the CCU.
- Connect the 4 cores to the connector on J20 (see Figure 56 - Connecting Water Level).

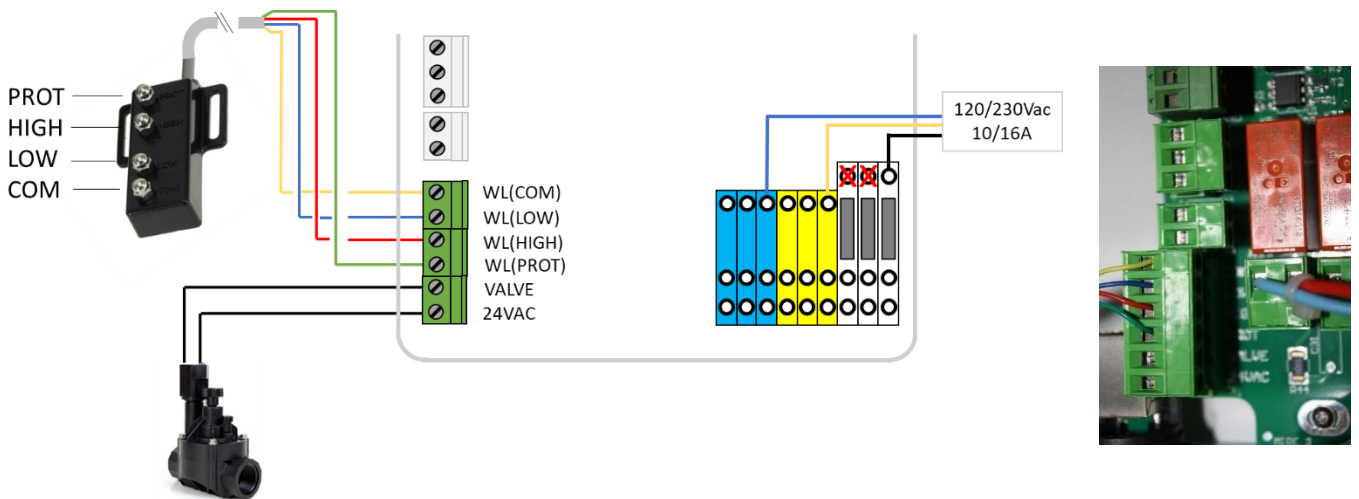

Figure 56 - Connecting Water Level



CAUTION:
Cable core colors may differ for different sensor manufacturing batches.
See notes to ensure correct wiring connections are made.

3.7.1.4 Water Supply



CAUTION:

Install the collar in a location such that the flow of water to the pool **cannot be isolated** by a manual valve.



CAUTION:

According to norms and regulations in place and depending on the origin of top up water, supply of fresh water in the pool must be done in a disconnecting overflow tank so that pool water cannot flow back in the supply network.

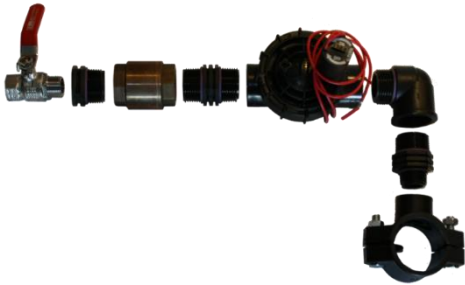

Figure 57 - Refill Valve and Fittings

- Fit a saddle onto the pool return pipe.
- Drill an appropriately sized hole through the return pipe.
- Fit the non-return valve and the solenoid valve.
- Verify that both valves are orientated correctly.
- Fit a stop valve, to shut off the main water supply when required.
- Use appropriate pipe to connect the main water supply to the solenoid valve.
- If buried, the pipe should be buried to a depth of at least 250mm.
- If not buried, secure the pipe in a neat and adequate manner.
- Once all piping and joints have been completed, open the main supply.
- Verify that the solenoid valve closes and seals correctly. Remove and replace if necessary.
- Verify all piping, joints, and connections for leaks. Repair all leaks before continuing.
- If necessary, extend the 2-core wire of the electrical solenoid.
- Feed the cable through a compression gland into the CCU.
- Connect the 2-core wire from the valve solenoid to the connector on J20 marked (VALVE) according to Figure 56 - Connecting Water Level. Polarity is not important.
- Reconnect electrical power supply to the PoolCop CCU.
- Switch the CCU **ON**.

3.7.2 Installing XM8

Read before starting electrical connection.

The electric standard applicable is **IEC 60364-7-702**. It is obligatory that your installation adheres to the criteria of this standard.

The XM8 provides 8 extras digital multipurpose inputs and 8 extras digital outputs (relays).

Relay usage will be defined in **AUXILIARIES** menu (see 5.3).

Input usage will be defined in **INPUTS** menu (see 5.6.4).

The XM8 enclosure is provided with compression glands size PG7 (for external diameter 3.5mm to 8mm), PG9 (for external diameter 3.5mm to 8mm) and PG11 (for external diameter 4mm to 10mm). The cables must pass through the appropriate compression gland size according to their diameter and the compression gland must be tightened to secure the cable.

Cables selection:

- ❑ For pump and auxiliary control: **H03VV or H05VV** with section **2x0.75**.
- ❑ Smaller sections and multiple conductor cables can be used depending on amperage (ex **JZ-602 12G0.5**).
- ❑ Cable selection and type must conform with local regulation.

Installing:

- ❑ Mount the XM8 in a weather-proof location close to the CCU. Ensure the unit is secured. The Unit is provided with 4 screws and 4 anchors for concrete. Make sure the wall material is compliant with these kinds of anchor or use the correct anchor.



NOTE:
The connection cable between CCU and XM8 is 1 meter long.
Make sure these modules are close enough to route the connection cable properly.

Connecting:

- ❑ Shut the CCU power down.
- ❑ Open the CCU cover and the XM8 cover with a screwdriver.
- ❑ Pass the cable for the XM8 through a compression gland of the CCU and secure it.
- ❑ Connect the cable extremity to J23 or J24.
- ❑ The XM8 will be powered by 12VDC provided by CCU. No need for an external power supply.

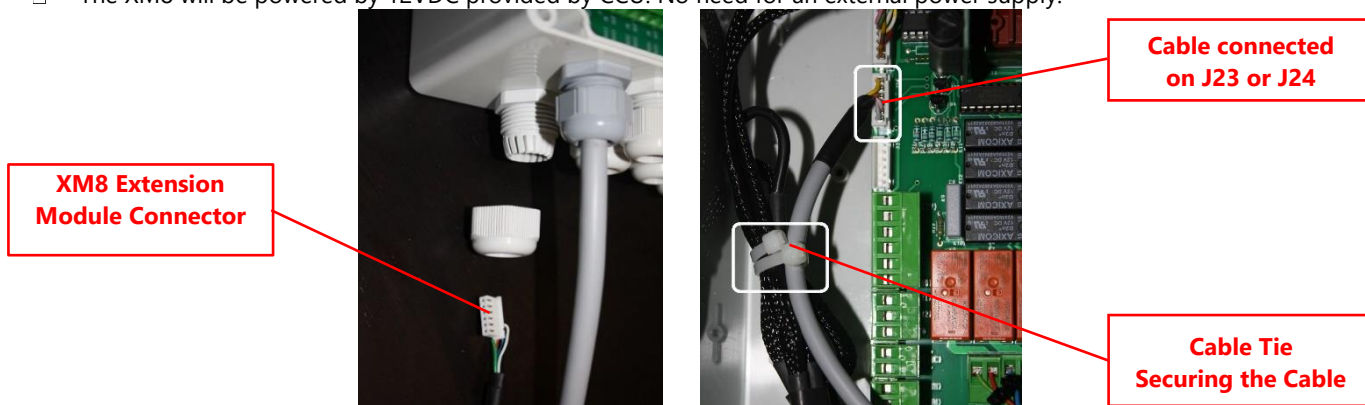

Figure 58 - Cables Entries

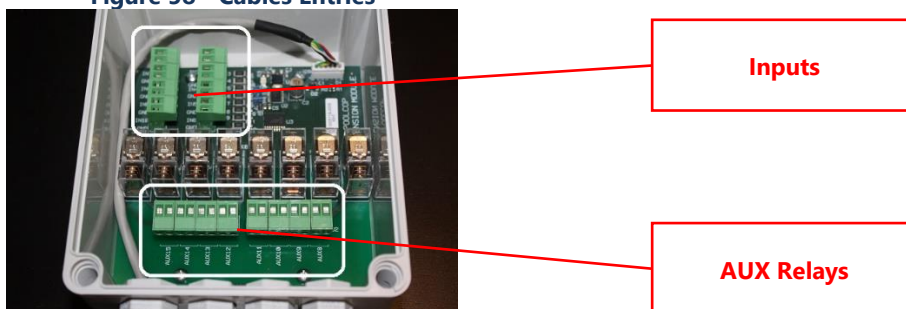

Figure 59 - Terminals

- ❑ See the appropriate section of this manual for connection details.
- ❑ Feed auxiliary equipment supply cables through a compression gland into the XM8.
- ❑ Switch the CCU **ON**.

Function	Relay Label	Relay ID	Connector	Rating	Examples of possible use
AUX	AUX8	K1	J2	6A/230V	Pool Heating, Booster Pump, Garden Lighting, Irrigation, Etc.
AUX	AUX9	K2	J2	6A/230V	Pool Heating, Booster Pump, Garden Lighting, Irrigation, Etc.

AUX	AUX10	K3	J2	6A/230V	Pool Heating, Booster Pump, Garden Lighting, Irrigation, Etc.
AUX	AUX11	K4	J2	6A/230V	Pool Heating, Booster Pump, Garden Lighting, Irrigation, Etc.
AUX	AUX12	K5	J1	6A/230V	Pool Heating, Booster Pump, Garden Lighting, Irrigation, Etc.
AUX	AUX13	K6	J1	6A/230V	JetStream *, Pool Heating, Booster Pump, Garden Lighting, Irrigation, Etc.
AUX	AUX14	K7	J1	6A/230V	Pool Cover OPEN Command *, Pool Heating, Booster Pump, Garden Lighting, Irrigation, Etc.
AUX	AUX15	K8	J1	6A/230V	Pool Cover CLOSE Command *, Pool Heating, Booster Pump, Garden Lighting, Irrigation, Etc.

* See extras functionalities in 3.7.6

Table 4 Relays and Power Ratings



WARNING:

**Never exceed the power ratings.
Always conform to local installation norms and requirements.**



CAUTION:

If you are unsure of the applicable wattage rating, contact the distributor of the auxiliary apparatus to confirm prior to connection.

Inputs table:

Function	Input Label	Connector	Examples of possible use
INPUT	IN3-GND	J11	Consumables Low, Pump Start, Pump Stop, Pool Cover, Etc.
INPUT	IN4-GND	J11	Consumables Low, Pump Start, Pump Stop, Pool Cover, Etc.
INPUT	IN5-GND	J11	Consumables Low, Pump Start, Pump Stop, Pool Cover, Etc.
INPUT	IN6-GND	J11	Consumables Low, Pump Start, Pump Stop, Pool Cover, Etc.
INPUT	IN7-GND	J12	Consumables Low, Pump Start, Pump Stop, Pool Cover, Etc.
INPUT	IN8-GND	J12	Consumables Low, Pump Start, Pump Stop, Pool Cover, Etc.
INPUT	IN9-GND	J12	JetStream Control * Consumables Low, Pump Start, Pump Stop, Pool Cover, Etc.
INPUT	IN10-GND	J12	Consumables Low, Pump Start, Pump Stop, Pool Cover *, Etc.

* See extras functionalities in 3.7.6

Table 5 Inputs Table



CAUTION:

**Inputs are self-powered with low voltage.
Only use potential free signal without any external power supply.**

3.7.3 Connecting BESGO 3 for pump suction

A BESGO 3 ways can be installed to select pump suction:

- Either via skimmers (or buffer tank)
- Either via the bottom of the pool

The valve must be controlled via the AUX4 relay and must be appropriately programmed (see 5.6.3 Filter Data).



CAUTION:
Use only a 3 ways valve.

- Valve installation on filter: please follow BESGO manual instructions.
- Electrical connection: SOV can be only powered with 230Vac.

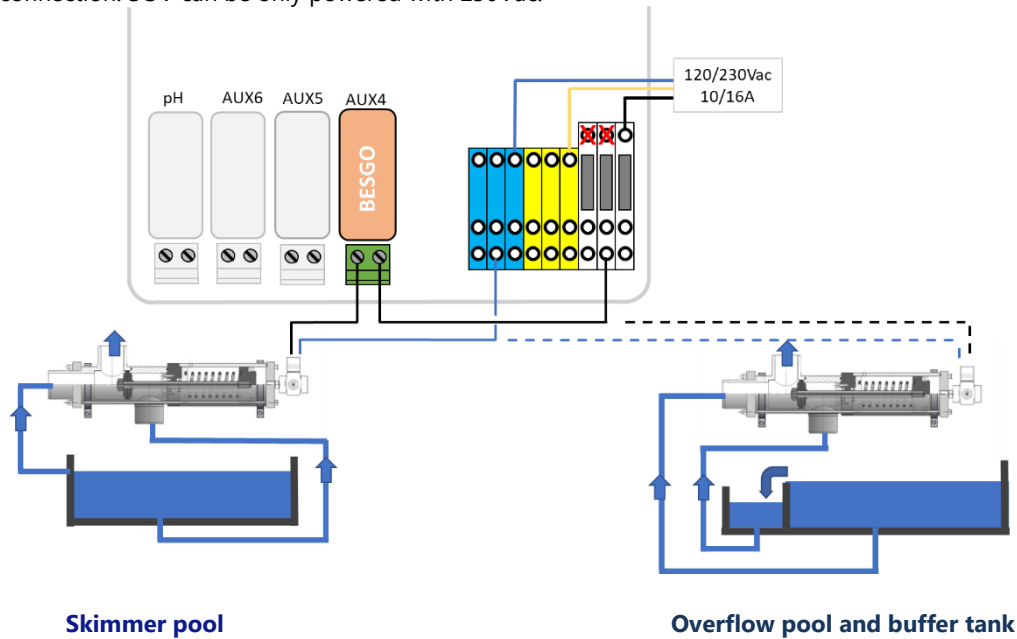

Figure 60 – Connecting BESGO for pump suction in 230Vac

3.7.3.1 Suction Programming

See 5.6.3 Filter Data

3.7.3.2 Testing

- Disconnect power to the solenoid and verify that:
 - Suction is done by the skimmers on a skimmer pool (type=Skimmer in "Pool Data").
 - Suction is done from the bottom of an overflow pool (type=Overflow.A or Overflow.B in "Pool Data").
- Restore power to the solenoid.
- Once the valve has been programmed, go to the **MANUAL CONTROL** menu.
- Initiate a filter cleaning from CLEAN **FILTER** menu. Suction during filter cleaning will be done either by the bottom of the swimming pool, or by the surface (skimmer or buffer tank) according to the programming.

3.7.4 Connecting an Automatic Valve on Waste Line

An external valve can be added to the waste line to avoid loss of water when the multiport valve is rotating. This can be especially useful when the pump house is above the water line. The valve must be controlled via the AUX5 relay and must be appropriately programmed in the 'Filter data' section.

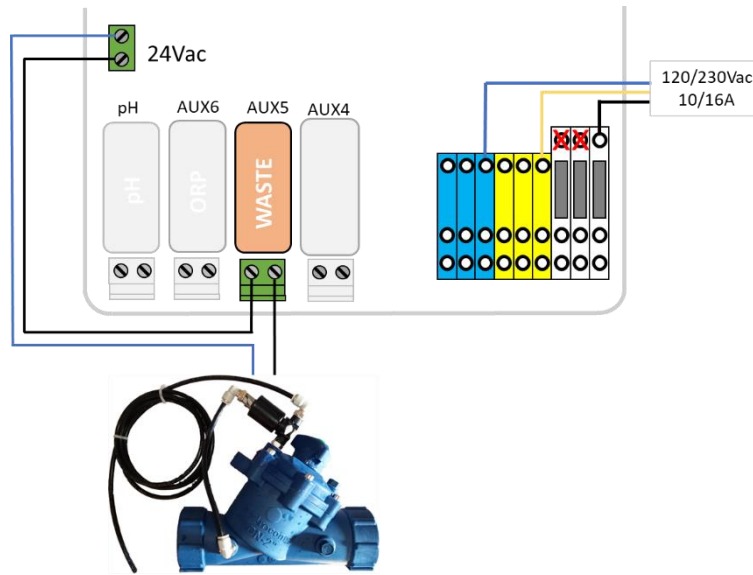

Figure 61 – Connecting Waste Valve

3.7.5 Using Modbus Hub connectors to connect Modbus devices.

The following devices use a Modbus communication protocol with PoolCOP:

- Space Hydrolysis system
- Free Available Chlorine Sensor (FAC)
- Energy Meters (EM).

To ease the connection of these devices, each one is provided with a cable terminated with a 6 pins quick connector. A Modbus Hub, installed inside the DCCU, provides four 6 pins IP67 sockets to receive Modbus devices.



Figure 62 – Four Modbus IP67 sockets.

Ensure that the following rules are respected when using the Modbus Hub:

- Devices can be connected to any unused socket by removing the plug.
- When connecting a **FAC**, it is mandatory to use the **rightmost** socket.
- Make sure there is a plug on every unused socket.



Figure 63 – Only one device connected, 3 plugs.



Figure 64 – FAC on the right plus 1 device connected, 2 plugs.

3.7.6 Connecting Equipment

3.7.6.1 Connecting a Pool Cover

A Pool Cover control functionality is available in Equipment settings. To achieve remote control, a compatible Pool Cover drive unit must be connected to the XM8. Pool Cover will be operated by “pulsing” the Open command or Close command to the drive. Basically, the operating mode will be able to replace the genuine button or key operated command.



WARNING:
 Remote control of a Pool Cover can cause severe injury. The user must always have the pool in direct view when maneuvering the cover and during opening or closing operations. The pool must be monitored at all times during the operation of the Pool Cover to ensure that no person is in the pool or enters the pool. The remote control of the Pool Cover is reserved for maintenance operations carried out by an authorized installer.



NOTE:
 See the Pool Cover manufacturer wiring diagrams to wire properly the signals. Aux14 is open command, Aux 15 is close command and In10 is closed position contact.

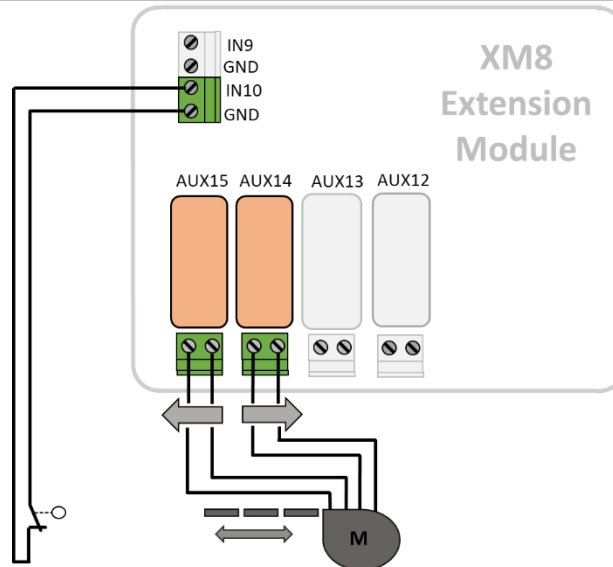

Figure 65 - Pool Cover Connection (Control and Position Indication)

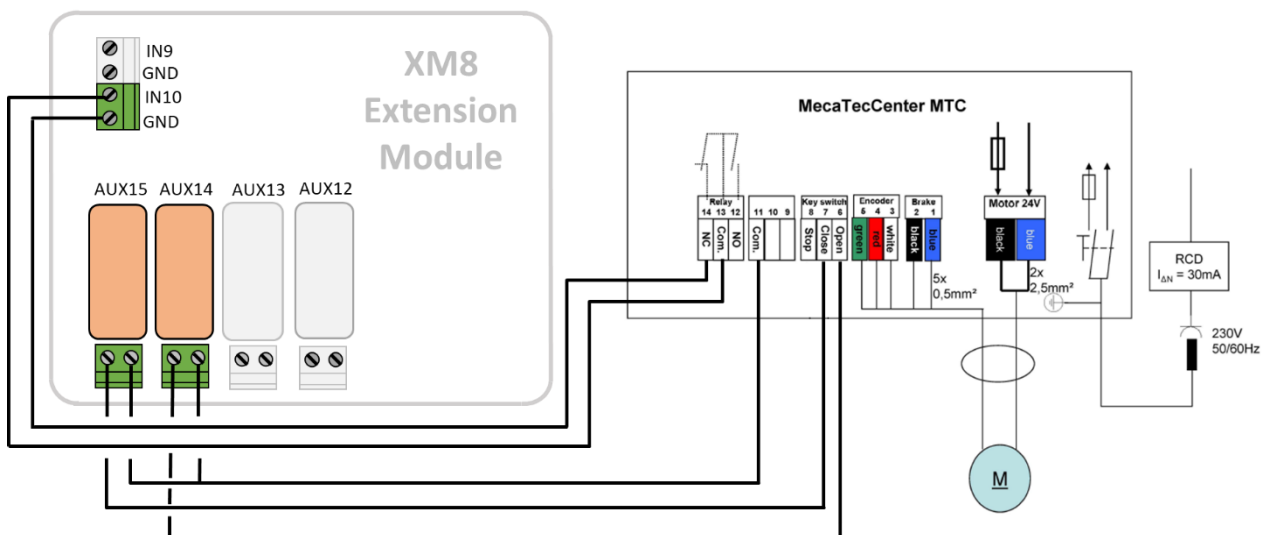

Figure 66 – Connection of MecaTecCenter cover

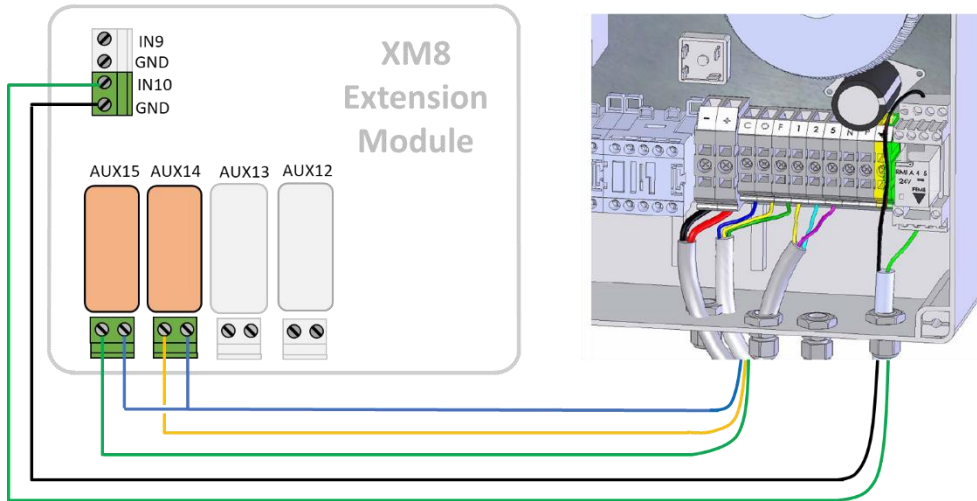

Figure 67 – Connection Astral Roussillon Cover

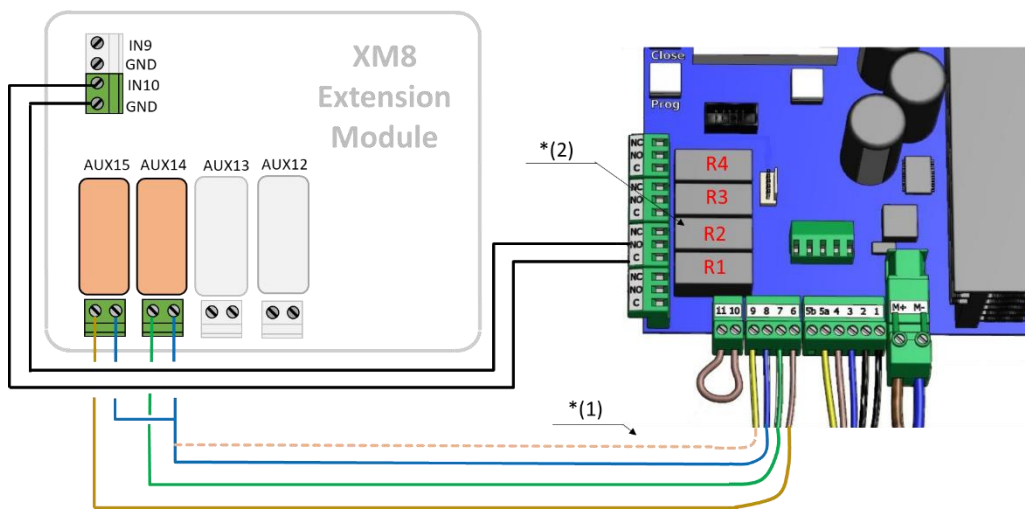

Figure 68 – Connection SWIMSAFE cover

Note * (1): If 8 and 9 are not interconnected, the cover can only be operated with the key on the local control panel. Otherwise, the key will no longer has any effect, and the control of the cover is always possible either locally either remotely.

Note * (2): In the configuration menu, assign function F1 (Open) for relay R2.

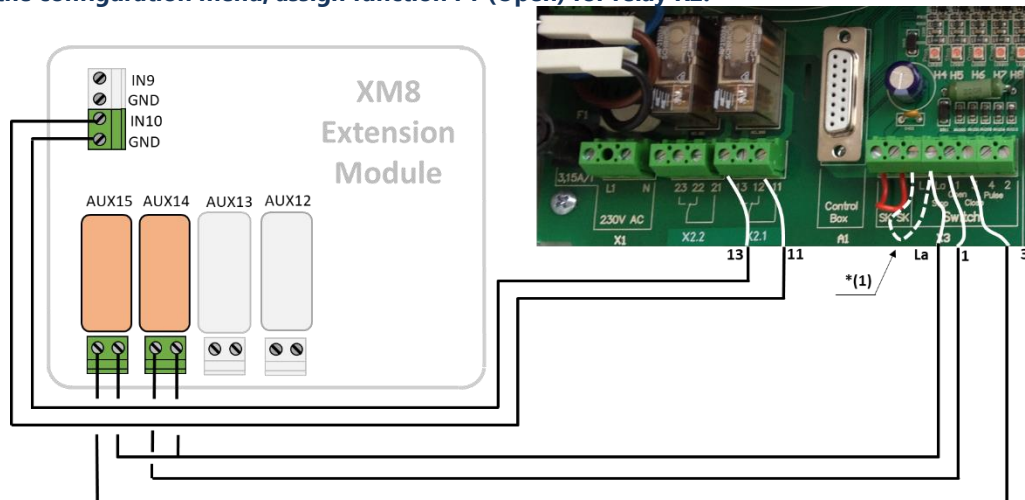

Figure 69 – Connection Aqua-Dec Cover

Note * (1): If L and La are not interconnected, the cover can only be operated with the key on the local control panel. If L and La are shortcuted, the key will no longer has any effect, and the control of the cover is always possible either locally either remotely. The deck control mode in menu 04 must be turned in "dead man" mode (Value=1).

3.7.6.2 Connecting a Jet Stream Pump

A Jet Stream pump is usually operated with a pneumatic push button in the pool. If the push button is connected to the XM8, Jet Stream will also be operable remotely and user will be able to choose a running duration (see 5.6.6 Equipment).

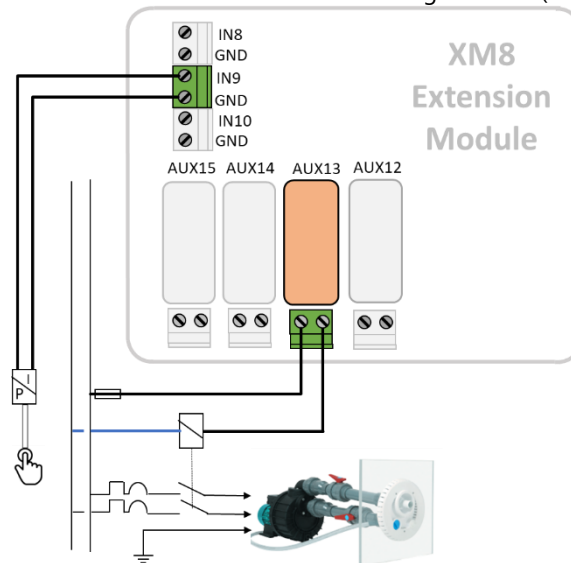

Figure 70 – Jet Stream Connection



NOTE:

Push button signal must be converted in ON/OFF contact before being connected to XM8.
This is usually done by a pneumatic switch inside the Jet Stream electric junction box.
Aux13 is Jet Stream pump command.

3.7.7 Circulation Flow Detection Sensor

A water circulation sensor may be installed to prevent chemicals from being injected when there is no flow at the injection points, where required. The water circulation sensor is installed in the return line to the pool upstream of the chemical injection points. Whenever no flow is detected, pH injection is inhibited, disinfection is inhibited, and any auxiliaries slaved to filtration pump are stopped. All these functions will restart automatically as soon as the water circulation is re-established. The installer must ensure that the sensor will react properly in case of:

- Loss of priming (no flow, no pressure).
- Pipe blockage (no flow, normal or high pressure).

The flow sensor cable must be routed through a compression gland and must be connected to one input in the CCU. Sensor is delivering a **Normally Open** potential free contact, which will close when flow is detected (see 8.4 Flow Switch for details).



WARNING:

The flow switch must be installed in a horizontal pipe section.
Never install on a vertical position.

Two models of flow sensors can be provided depending on availability:

- Flow Sensor Type 1 with a male thread, paddle length to be adjusted.
- Flow sensor Type 2 with female thread, with fixed paddle length.

3.7.7.1 Flow Sensor Type 1

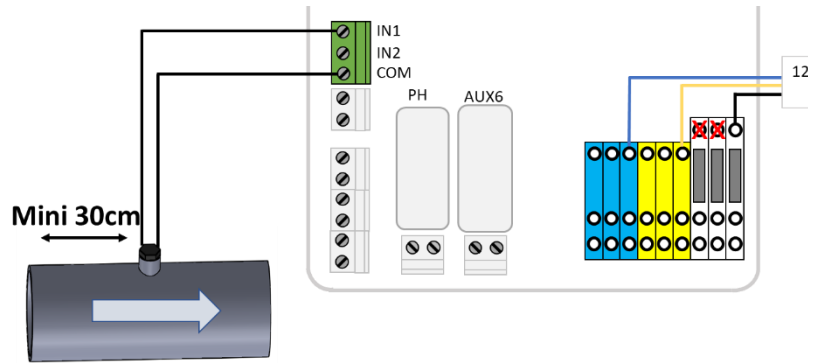

Figure 71 - Flow Switch

Figure 72 - PVC Saddle

Figure 73 - Connecting Flow Switch to Input (1)

The flow switch must be installed:

- Using a provided saddle. Two saddles are supplied, select the correct saddle according to pipe dimension (PVC Schedule 40/80, in 1.5" or 2" for example). Alternatively use a standard saddle clamp suitable for the pipe diameter, with 3/4" female thread fitting.
- In the return line to the pool, post filtration.
- After (downstream) all the pool equipment (filter, heater, solar, etc.).
- Before the chemical injection or salt cell.
- Mounted on a horizontal pipe.
- With at least a 30 cm (12") straight pipe run before (upstream) the flow switch.
- Adjusted to the correct paddle length according to the pipe diameter:
 - o The paddle can be cut at various lengths upon pipe diameter.
 - o There are cut lines numbered 1 to 6 every 5mm (0.2").
 - o There must be a 5 mm (0.2") minimum gap between end of the paddle and opposite pipe wall.
 - o Cut segment #6 for 1.5" pipe.
 - o Do not cut for 2" or larger pipe.
- Mounted with PTFE tape to ensure tightness.
- With the arrow on the switch housing aligned exactly parallel to the pipe in the direction of the water flow.

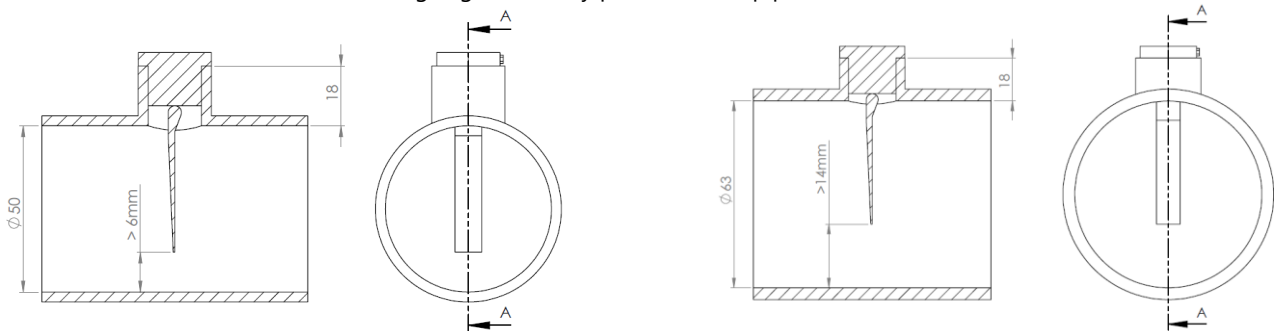

Figure 74 - Flow Switch Paddle Length Adjustment

3.7.7.2 Flow Sensor Type 2



Figure 75 - Flow Switch



Figure 76 – Drill Hole
Ø 20mm (¾")

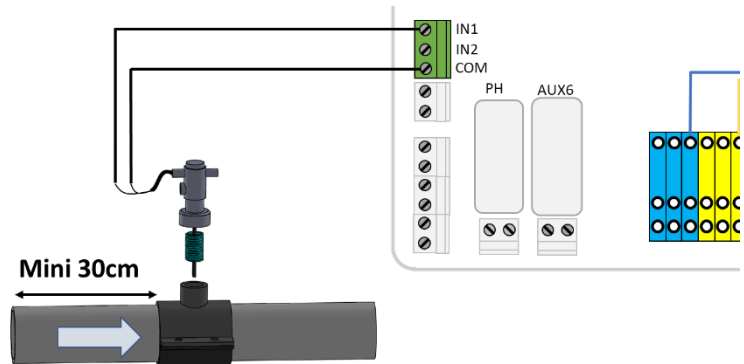

Figure 77 - Connecting Flow Switch to Input (1)

The flow switch must be installed:

- Using a standard saddle clamp (not provided) suitable for the pipe diameter, with ¾" male thread fitting. Alternatively, a standard saddle clamp suitable for the pipe diameter, with female thread fitting can be used with a suitable male-male thread adapter.
- In the return line to the pool, after filtration.
- After (downstream) all the pool equipment (filter, heater, solar, etc.).
- Before any treatment (the chemical injection point or salt system cell).
- Mounted on a horizontal pipe.
- With at least a 30 cm (12") straight pipe run before (upstream) the flow switch.
- Before placing the saddle clamp, drill a Ø 20mm (or ¾") hole on top of the pipe (see above).
- Fit the flow switch to the saddle clamp with PTFE thread tape to ensure water tightness.
- Orientate the flow switch with the arrow on the switch housing exactly parallel to the pipe and in the direction of water flow.
- Tighten the fittings to ensure water tightness. Do not overtighten.

3.7.7.3 Flow switch operational test

- Wire the cable ends to one Input with the cable routed through a compression gland.
- Test to ensure proper operation:
 - In **MANUAL CONTROL, PUMP**, start the pump, wait for priming and stable water circulation.
 - In **CONFIGURATION, INPUTS** menu, configure an input as "flow switch" and check the status of the Input. Status should be **ON**, if status is **OFF**, check the wiring and Input configuration (see 5.6.4)
 - In **MANUAL CONTROL, PUMP**, stop the pump.
 - In **CONFIGURATION, INPUTS** menu, check the status of the Input. Status should be **OFF**. If status is **ON**, check the wiring and Input configuration (see 5.6.4)

3.7.8 Connecting an Eva Optic led pool light

Eva Optic Led and PoolCOP can be associated to both control light ON/OFF and control Color.

For such a control, two AUX outputs will be necessary on PoolCOP:

- One AUX will toggle light ON and OFF (AUX nn on the drawing).
- One AUX will change color (AUX mm on the drawing). This AUX must be configured in pulse mode with a pulse duration of 2 seconds. (See 5.3 Auxiliaries Menu).
- AUX can be selected amongst any available, they don't need to be adjacent.

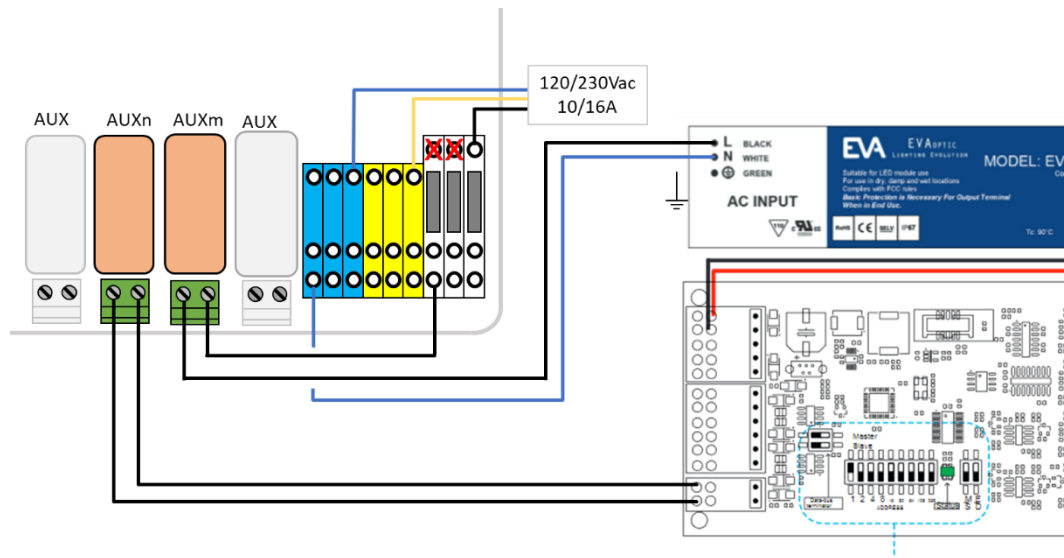

Figure 78 – Connecting Eva Optic Led Light

3.7.9 Connecting an heating system

PoolCOP provides an algorithm to heat the pool. Although any heating device can be used, most often a heat pump is used. There are 3 methods to control the heat pump:

1. The most "basic" but which works in each case:
 - Insert a contactor to supply power to the heat pump (rating of the contactor to be chosen according to the nominal power of the heat pump).
 - The AUX output dedicated to heating will energize the coil of the contactor which, in turn, will energize the heat pump.
 - When heating is requested, the heat pump will be energized.
 - When heating is not required, the energy to the heat pump is removed.
2. A little more elaborate, using the heat pump "flow switch".
 - A heat pump is always equipped with a flow switch which prevents heat production in case of lack of water flow.
 - If access to the flow switch electrical terminal block is accessible, and if changing the wiring will not void the heat pump warranty, insert the AUX output contact dedicated to the heating in serial with the flow switch.
 - When heating is requested, the signal coming from the flow switch will be enabled (security is granted).
 - When heating is not required, the flow switch signal is disabled, simulating a "no flow" situation.
3. Some Heat pumps allow a "Remote" ON/OFF control.
 - When this is the case, it is clearly described in the installer manual.
 - Most often, there is a "bridge" on a terminal block, so:
 - Disconnect the bridge.
 - Insert the AUX output contact dedicated to the heating to replace the bridge.
 - When heating is requested, the system is turned ON.
 - When heating is not required, the system is turned OFF.

Note: the temperature setpoint on the heat pump must be set higher than the desired water temperature set in PoolCOP Auxiliary setting.

3.8 COMPLETING THE INSTALLATION

- Verify that all wiring has been done according to applicable electrical norms.
- Verify that the pH+ORP electrode or blanking plug is secure, with O-Ring in place.
- Verify that the power switch on the CCU is in the **OFF** position.
- Close the CCU cover.
- Connect the circuit breakers to the CCU and associated equipment.

3.9 COMMISSIONING POOLCOP

- Switch the CCU **ON**.
 - The **Power** and **12VDC Supply** LED's must illuminate.



CAUTION:
If this equipment stays on for longer than 2 seconds, IMMEDIATELY switch OFF the CCU.
Recheck all connections.
If only the pump runs, disconnect the circuit breaker, switch ON the PoolCOP and reset factory default settings. Now reconnect the pump circuit breaker and continue with commissioning.

- The PoolCOP will display the following sequence:
 - Welcome note with firmware version (5 seconds).
 - Pump **OFF**.
 - **FILTER** position selected and valve might rotate to filter position.
 - Once filter position is confirmed, the main screen will be displayed.
- Open all appropriate valves and remove any plugs in the filtration system.



CAUTION:
If leaks are found, switch OFF the CCU.
Repair all leaks and repeat the procedure, if required.

- Switch the pump **ON** from the **MANUAL CONTROL** menu.
- With the pump and filtration running, carefully check for leaks, especially in the following places:
 - pH+ORP sensor or blanking plug.
 - Seal between Valve Data Unit base and/or 2" Adapter and the multiport valve housing.
 - Filter connectors.
 - All valves and pipe connectors.
- Verify correct functioning of auxiliaries by switching them **ON/OFF** in the **MANUAL CONTROL** menu.

3.10 POST INSTALLATION INSPECTION, DOCUMENTATION, PROCEDURES

3.10.1 Post Installation Inspection

After completing the installation, the installer will:

- Verify that all the wiring is neat and safe.
- With the system running, verify no water leaks.
- Verify that the water balance is in the acceptable range.
- Verify correct functioning of the equipment and peripherals, including the pool light.

3.10.2 Post Installation Documentation

Complete the product warranty registration card.

3.10.3 Post Installation Procedures

Ensure that the client has a broad knowledge of the installation, understands the functions of the PoolCop and the alerts:

- Introduce system and point out main components and their functions.
- Explain basic system operation, using the User Guide.
- Explain that once the water is balanced, the PoolCop takes over the filtration and other functions as installed within normal parameters.
- Remind the owner that the PoolCop is a management system, not a repair system. Events outside of the norm may require intervention and water balance.
- Show Air Temperature Sensor location (if installed)
- Show the Water Level Control (if installed):
 - Sensor location and cable routing.
 - Position and use of the water supply shut-off.
 - Pipe routing of the water supply.
- Show water treatment options and consumables (if installed).
- Show auxiliary equipment connected (if installed).
- Show inputs connected (if installed).
- Explain the water treatment options as installed, including the verification of consumables.
- Hand over completed User Guide.

Section 4 USER GUIDE

- 4.1 PoolCOP Configuration.....64
- 4.2 Keypad and Display Layout.....64
- 4.3 Menus.....65
 - 4.3.1 Manual Control.....66
 - 4.3.2 Filtration Modes.....67
 - 4.3.3 Auxiliaries.....68
 - 4.3.4 Water and Treatment.....69
 - 4.3.5 Maintenance.....70
 - 4.3.6 Configuration.....70
 - 4.3.7 PoolCOP Cloud.....71
 - 4.3.8 Set PIN Code.....71
 - 4.3.9 Circulation Mode (if suction valve is present).....71
- 4.4 Using and Settings.....72
 - 4.4.1 Illuminate the Backlight.....72
 - 4.4.2 Navigate the Menu.....72
 - 4.4.3 Return to Main Display.....72
 - 4.4.4 Filtration and Pump Control.....73
 - 4.4.5 Water Level Control.....81
 - 4.4.6 Water Treatment.....82
 - 4.4.7 Auxiliary Control.....82
 - 4.4.8 Equipment Control (requires XM8).....83
 - 4.4.9 Service Mode.....84
- 4.5 Troubleshooting and Alerts.....85
 - 4.5.1 General Troubleshooting.....85
 - 4.5.2 Electrical Power Failure.....86
 - 4.5.3 Alerts and System Messages.....86

PoolCOP has been designed to relieve much of the burden and cost of pool maintenance, whilst reducing the cost and requirement for chemical products. The pool will be a healthier swimming environment.

PoolCOP is not a repair system. Pay prompt attention to any Alerts. In the unlikely event of malfunctions call the installer. Following the guidelines in this manual and maintain the equipment in accordance with the maintenance schedule to ensure trouble free operation and an easily maintained swimming pool.

4.1 PoolCOP Configuration

The equipment will be programmed by the installer.

4.2 KEYPAD AND DISPLAY LAYOUT

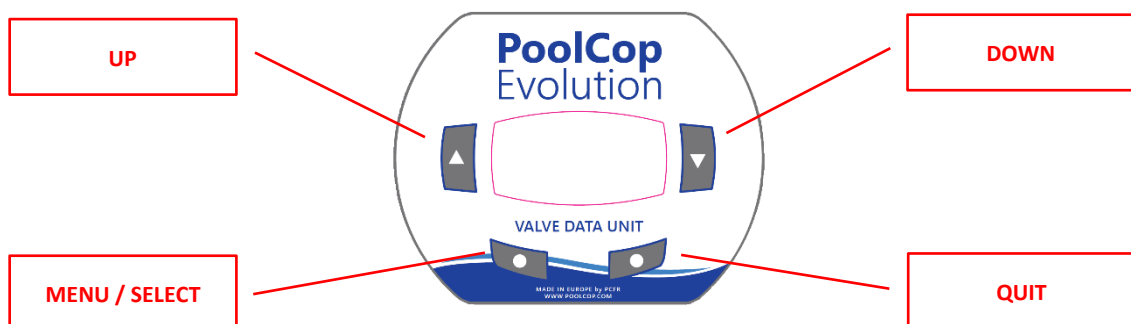
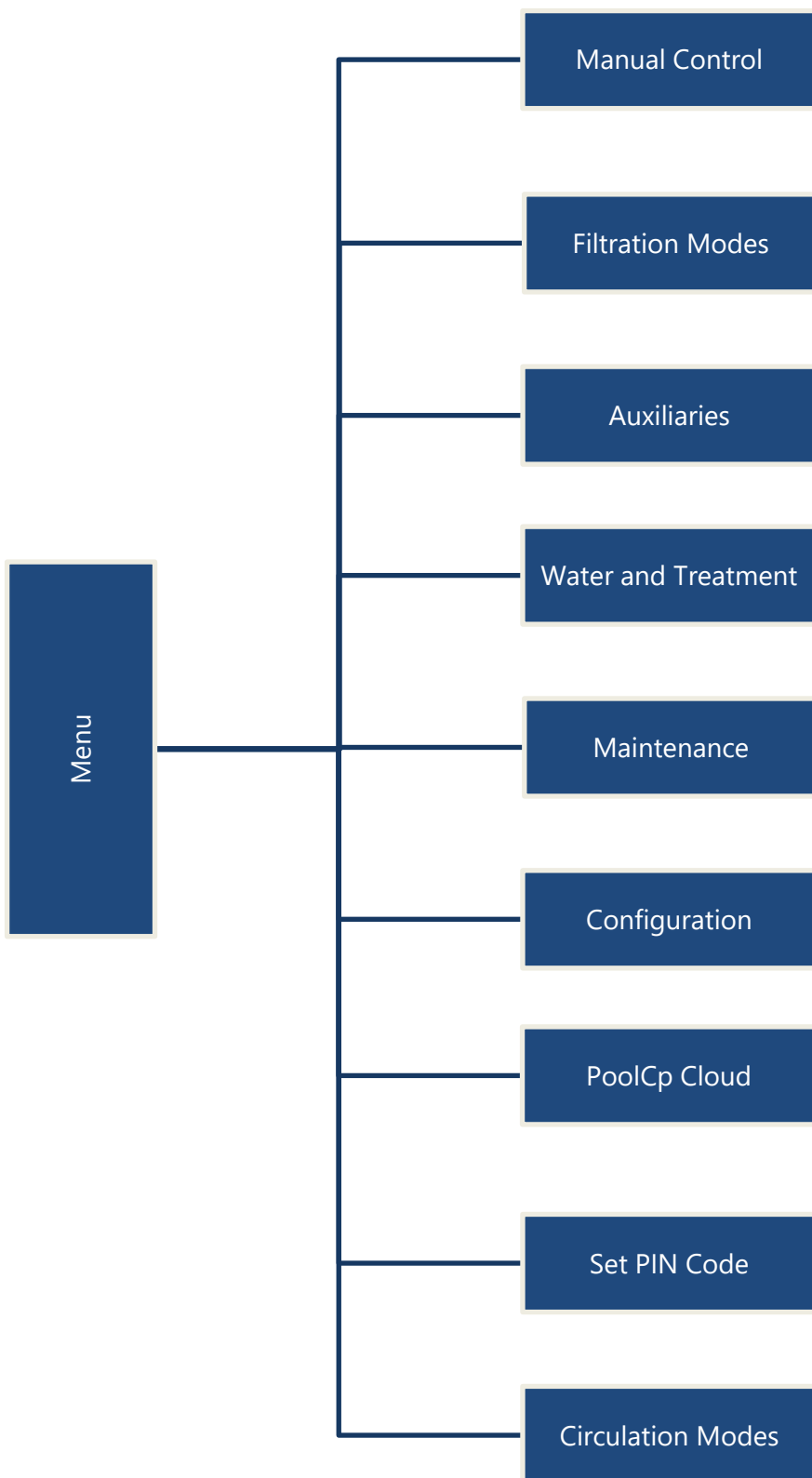
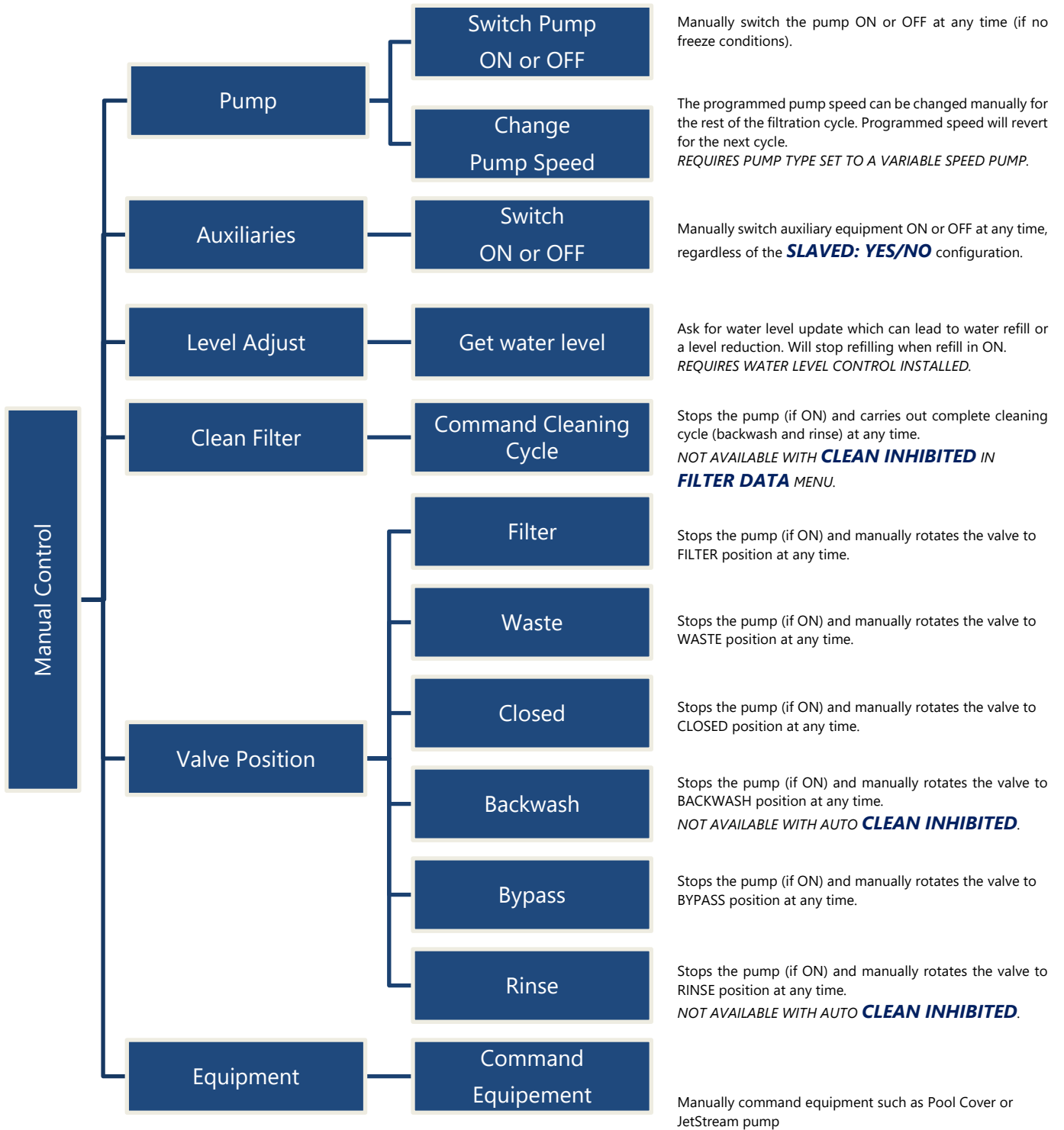

Figure 79 - CCU Display and Keypad

4.3 MENUS



4.3.1 Manual Control



4.3.2 Filtration Modes

Program filtration timers and duration, manually or in automatic modes.

Whenever quitting the **FILTRATION MODES** menu, PoolCOP checks and adjust the status of the pump and auxiliaries and switches them **ON** or **OFF** as required to match programmed run times.

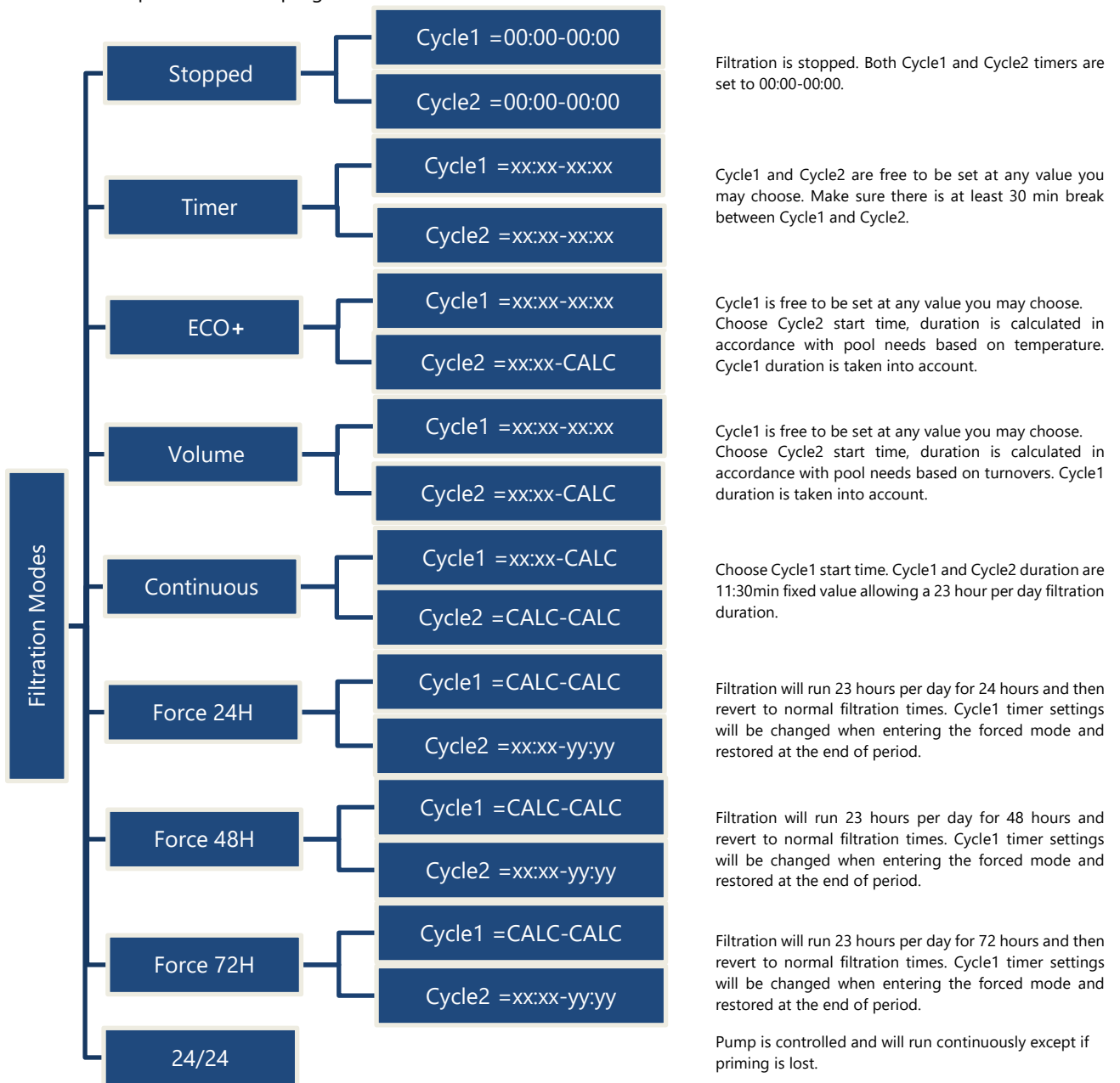

4.3.3 Auxiliaries

Program auxiliary timers and set them as slaved to run with the pump only, or on specific day.

Whenever quitting the **AUXILIARIES** menu, PoolCOP checks and adjust the status of the pump and auxiliaries and switches them **ON** or **OFF** as required to match programmed run times. AUX channels operate in the same manner, but some channels may be required for specific functions.

Note: Aux 8 to Aux 15 only available with XM8.

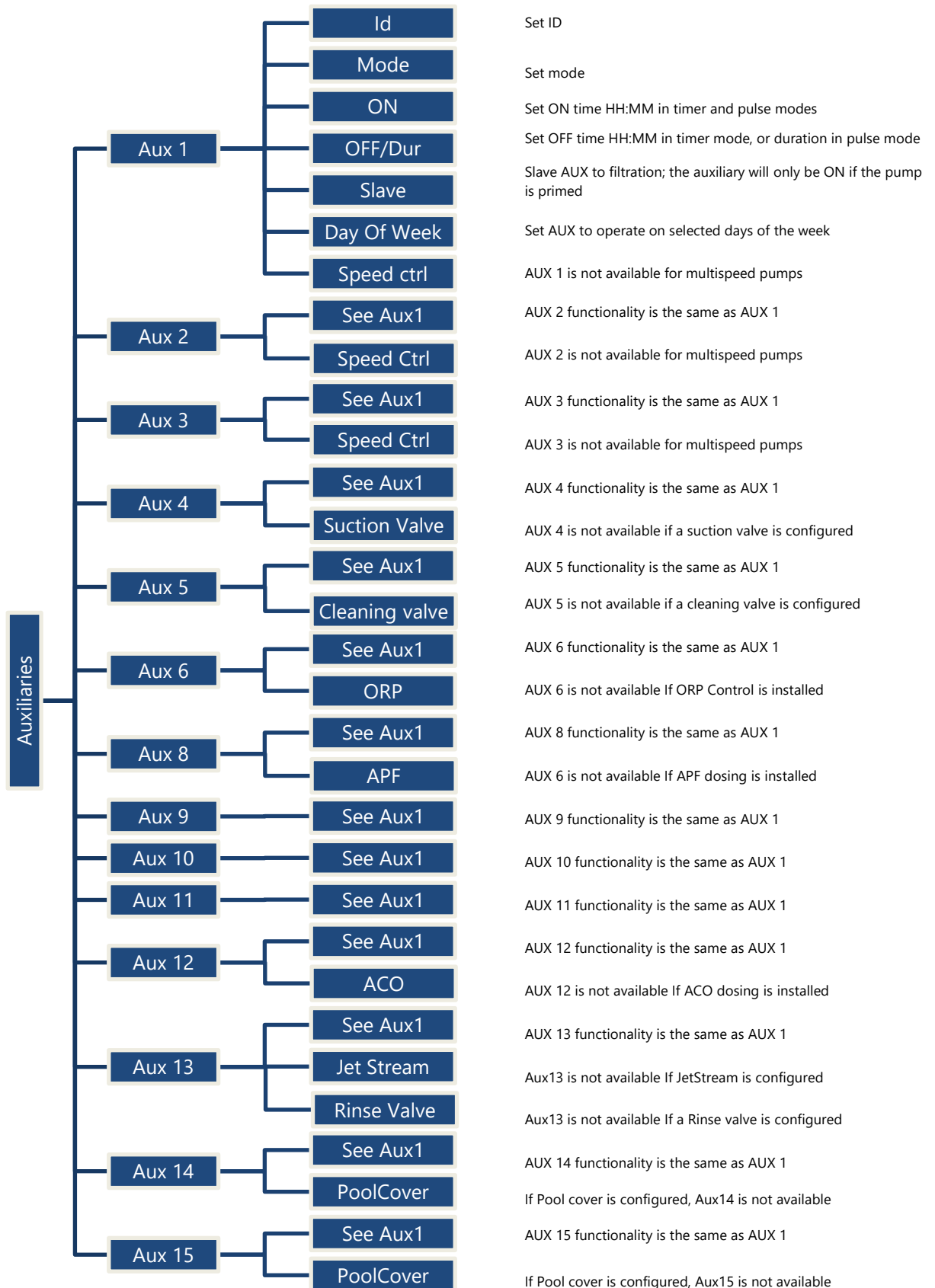

4.3.4 Water and Treatment

View and adjust various water level and treatment options available.

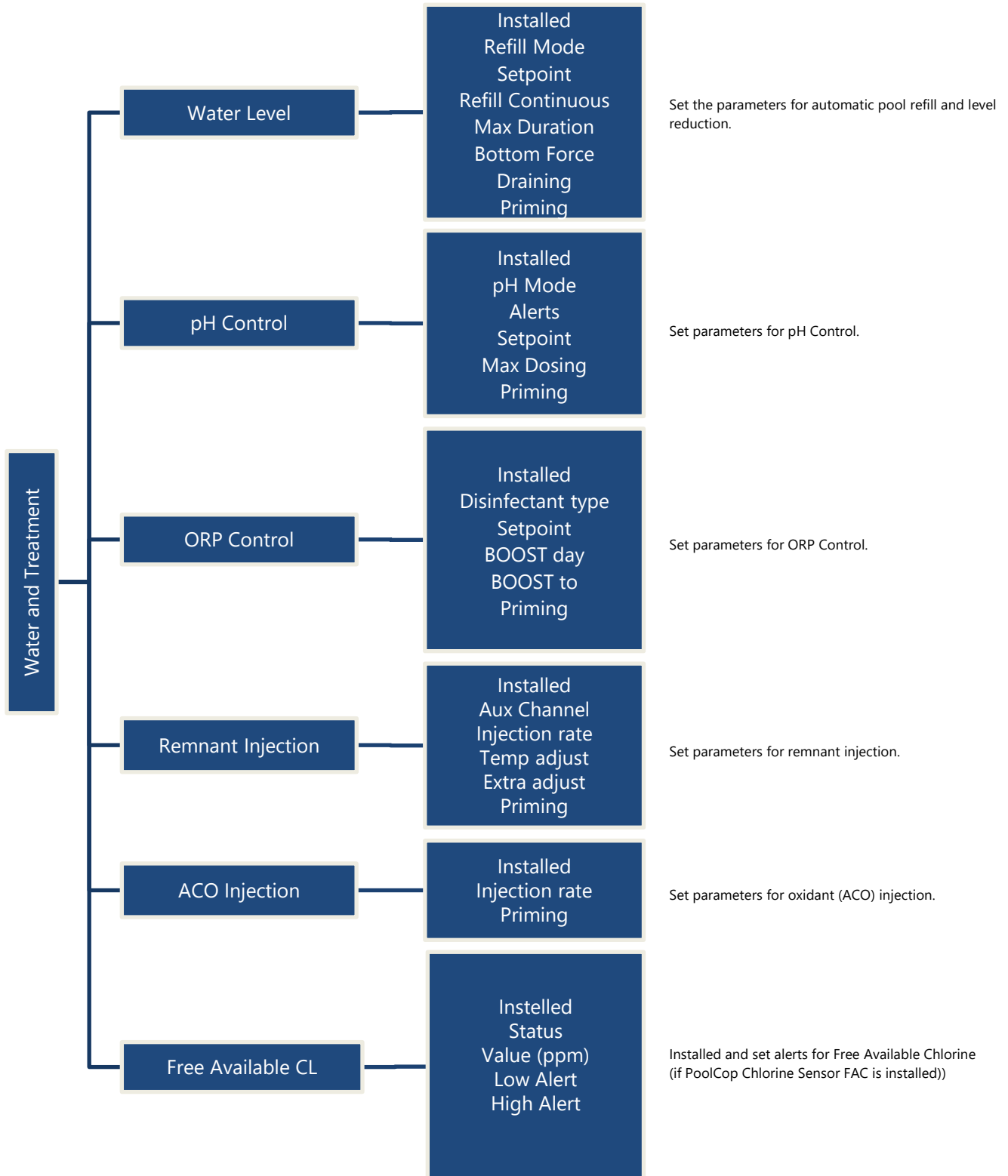

4.3.5 Maintenance

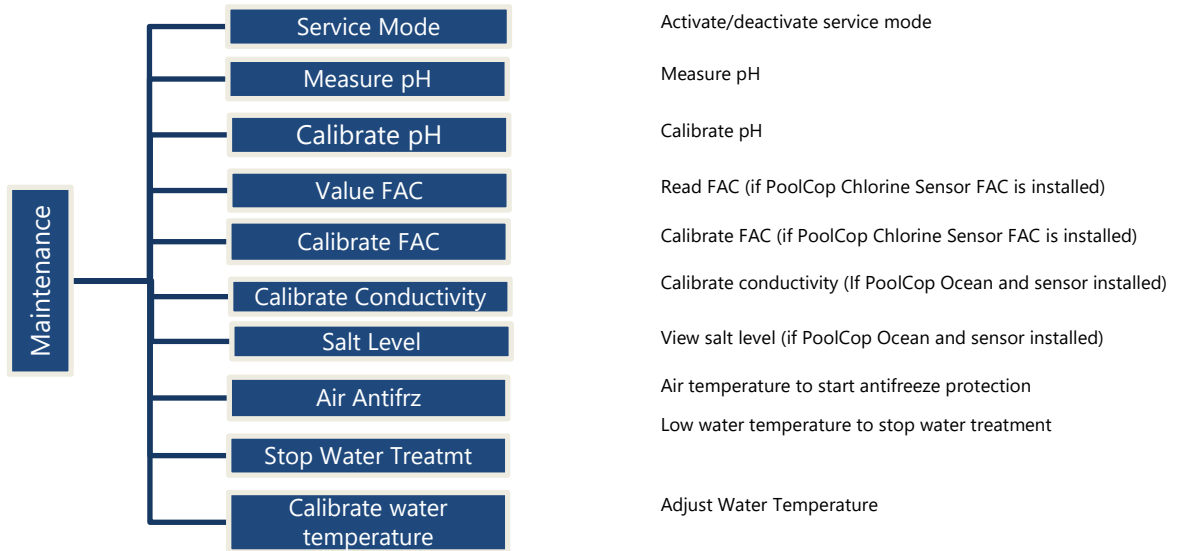

4.3.6 Configuration

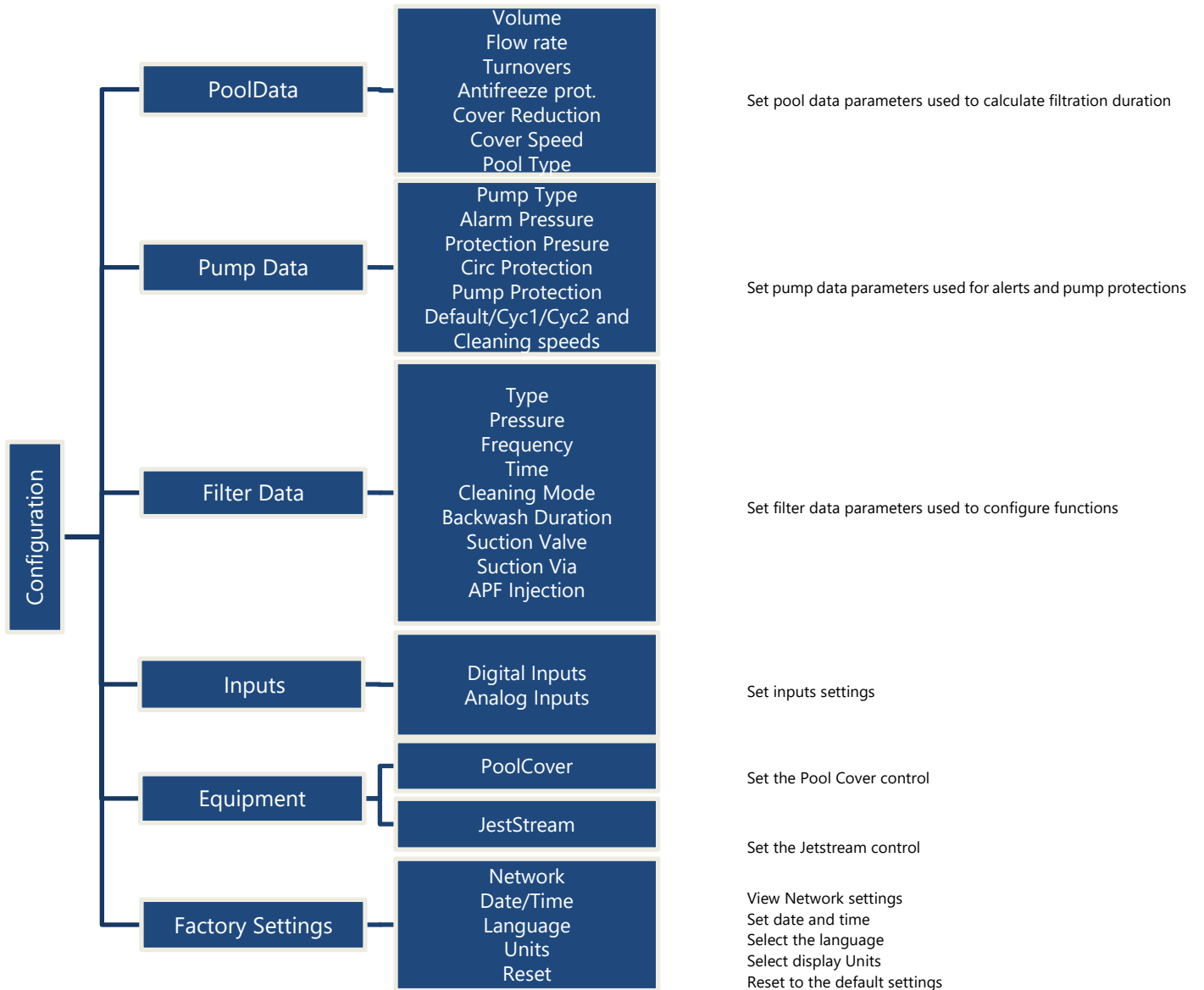

4.3.7 PoolCop Cloud

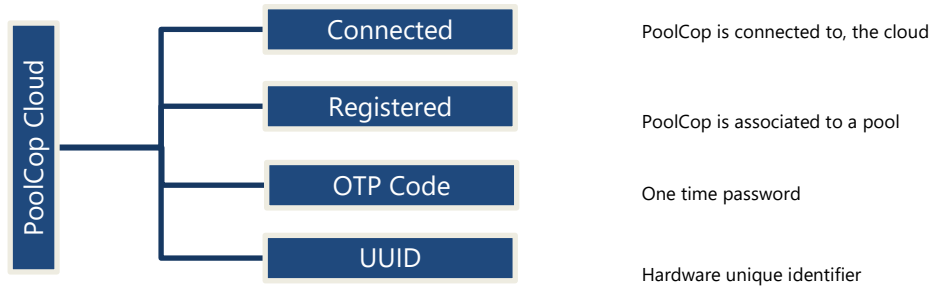

4.3.8 Set PIN Code



4.3.9 Circulation Mode (if suction valve is present)

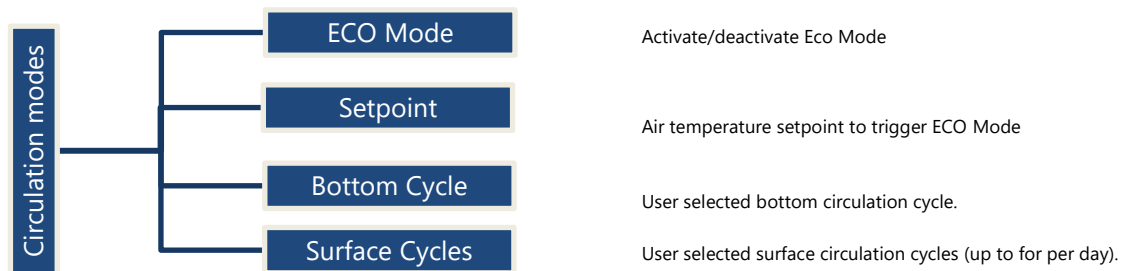

4.4 USING AND SETTINGS

4.4.1 Illuminate the Backlight

Pressing any button illuminates the backlight.
The backlight remains on for 3 minutes.

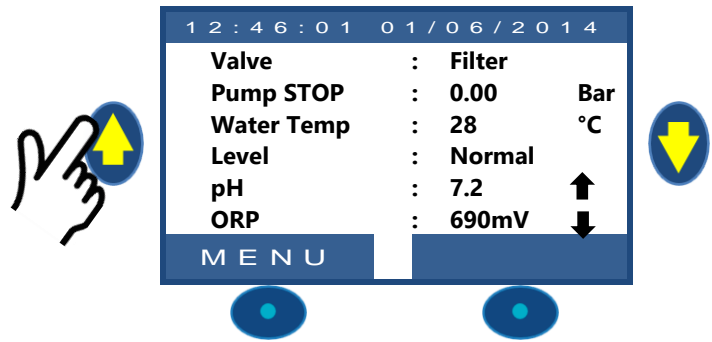

Note:

- Water temperature and air temperature are shown alternatively on the same row.
- An Up or Down steady arrow** may appear on the right of pH value: this will be the case if:
 - pH is controlled by PoolCOP (pH control is installed, and pH type is pH+ or pH-).
 - Up arrow: pH value is more than 0.1 above setpoint.
 - Down arrow: pH value is more than 0.1 below setpoint.
- Three blinking arrows** appear to the right of the 'pH' text if a dosing is in progress. Arrows oriented downwards if pH- dosage, upwards if pH+ dosage.
- An Up or Down steady arrow** may appear on the right of ORP value: this will be the case if:
 - ORP is controlled by PoolCOP (ORP control is installed and ORP type is different from "Read").
 - Up arrow: ORP value is more than 50mV above setpoint.
 - Down arrow: ORP value is more than 50mV below setpoint.
- Three flashing arrows** appear to the right of the 'ORP' text if a dosing is in progress. The arrows are oriented upwards to indicate that the assay seeks to increase the Redox value.

4.4.2 Navigate the Menu

- Press the **MENU** button.
- POOLCOP MENU** is displayed.
- Use the **UP** and **DOWN** buttons to choose the submenu (in this case Manual Control), then press **SELECT** to go to that submenu.
- Repeatedly pressing **QUIT** to return to the main display.

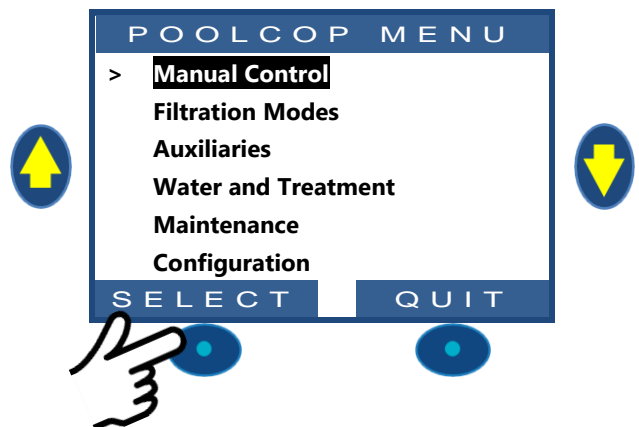

4.4.3 Return to Main Display

When viewing any menu screen:

- Press **QUIT** to go up one menu level.
- Every display has a 15 second timeout to go back to the previous menu. The display will timeout to the main display within approximately 1 minute.

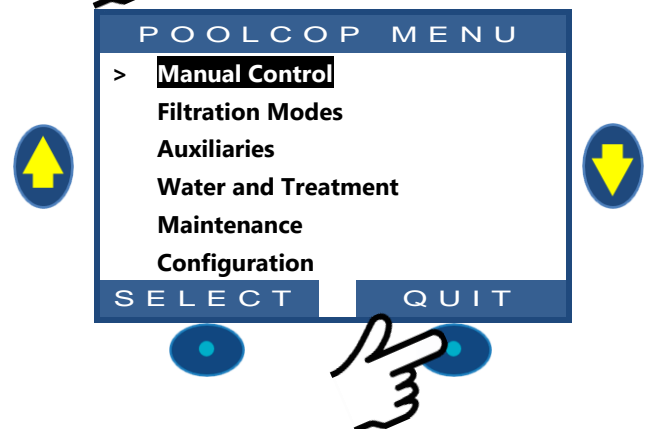

4.4.4 Filtration and Pump Control

4.4.4.1 Switch the Pump ON/OFF

4.4.4.1.1 Start the Pump

Normally, the filtration pump is controlled automatically by PoolCOP using filtration in manual timer or automatic modes. If, however you want to run the pump at another time or need to restart the pump after stopping it for any reason, this is done from **MANUAL CONTROL**.

From the main display screen:

- Press **MENU**.
- Press **SELECT** (**MANUAL CONTROL** is preselected).

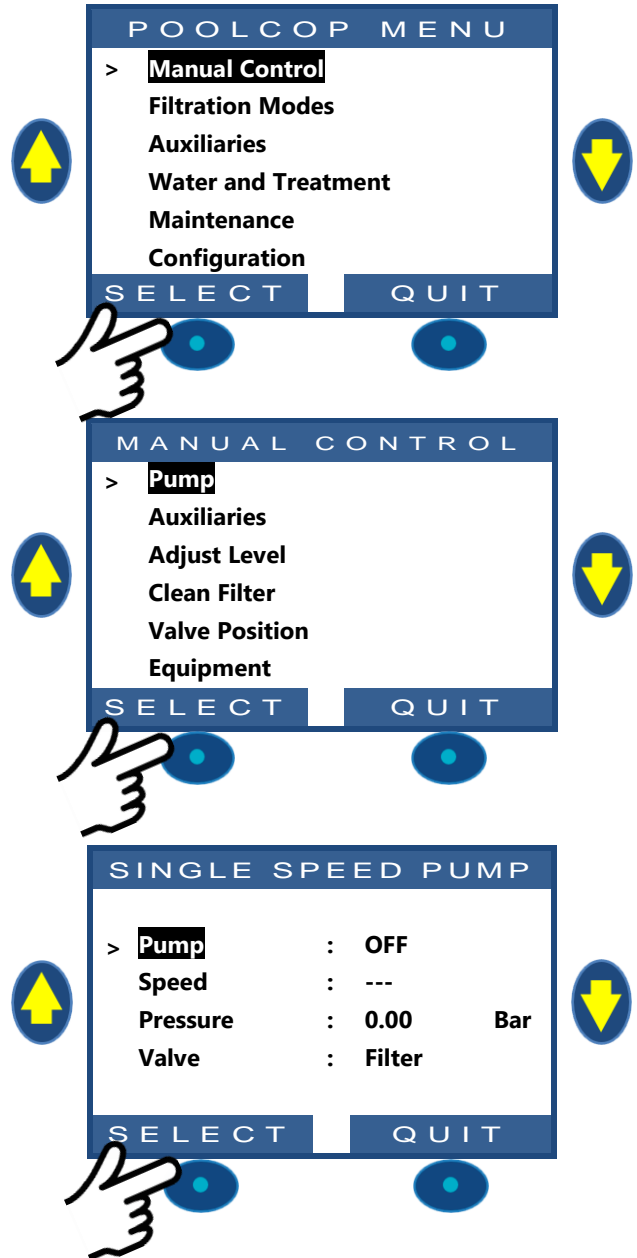

- Press **SELECT** (**PUMP** is preselected).

- Press **SELECT** (**PUMP** is preselected).
- Press **SELECT**; **PUMP: ON** will display.
- Press **SELECT**; the pump will run.
- Once the pump starts system pressure increases and this will be displayed.



CAUTION:

If the valve is in position Waste, Backwash or Rinse, pool water level will reduce.



NOTE:

If the valve is Closed, pump will not be allowed to start.

4.4.4.1.2 Stop the Pump

- Navigate to pump **MANUAL CONTROL**.
- The pump will be **ON**, and pressure will be displayed.
- Press **SELECT** (**PUMP** is preselected).
- Press **SELECT**; **PUMP: OFF** will display.
- Press **SELECT**. The pump will stop, and pressure will reduce.

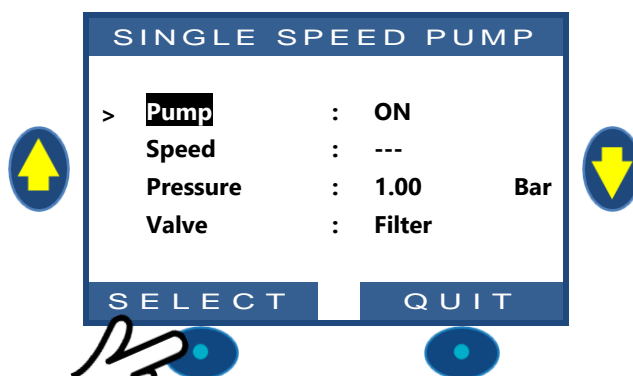

NOTE:

If the pump and filter are lower than the pool water level, head pressure will be displayed otherwise pressure will be zero.



NOTE:

When freezing risk is detected and filtration started, the pump CANNOT be stopped until the temperature detected is higher than the protection setting, or the Protection Antifreeze is switched OFF in the Pool Data menu.

4.4.4.1.3 Change the Pump Speed

This feature is available with variable speed pumps only; for configuration see the **PoolCOP Variable Speed Pump Guide**. Pump speed is linked to filtration and Filter Cleaning Cycles; the speed can be changed by the user with the pump **ON** and this speed will be maintained until the next programmed Filtration Timer cycle commences or until the next filter cleaning cycle starts.

- Navigate to **MANUAL CONTROL** (**PUMP** is pre-selected).
- Press **SELECT**; Pump Manual Control displays.
- Select **SPEED**.
- Press **SELECT** and scroll **UP** or **DOWN** to select desired speed.
- Press **SELECT** to activate the speed.

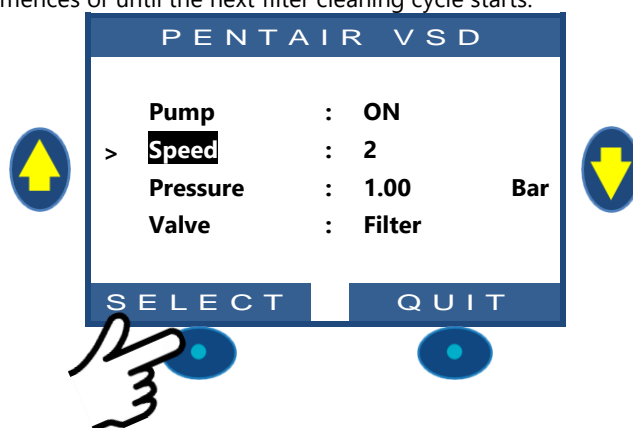

NOTE:

The number of speeds available depends on the pump specifications. PoolCOP sends the corresponding speed signal to the pump; due to pump design and features there can be a delay between selecting the speed and the pump reacting.

4.4.4.2 Manual Valve Control

Valve positions can be selected manually as required. The pump is automatically stopped when a new valve position is selected to allow valve rotation. Filtration programming always has priority over a manually selected valve position. If left in any position except filter, when the next filtration cycle is activated, the pump will stop if ON, and the valve will rotate to Filter position, and then the pump will run the programmed filtration cycle.

- ❑ Press **MENU: POOLCOP MENU** displays (Manual Control preselected).
- ❑ Press **SELECT**: Manual Control displays.
- ❑ Scroll **UP** and **DOWN**: place cursor at Valve Rotation.

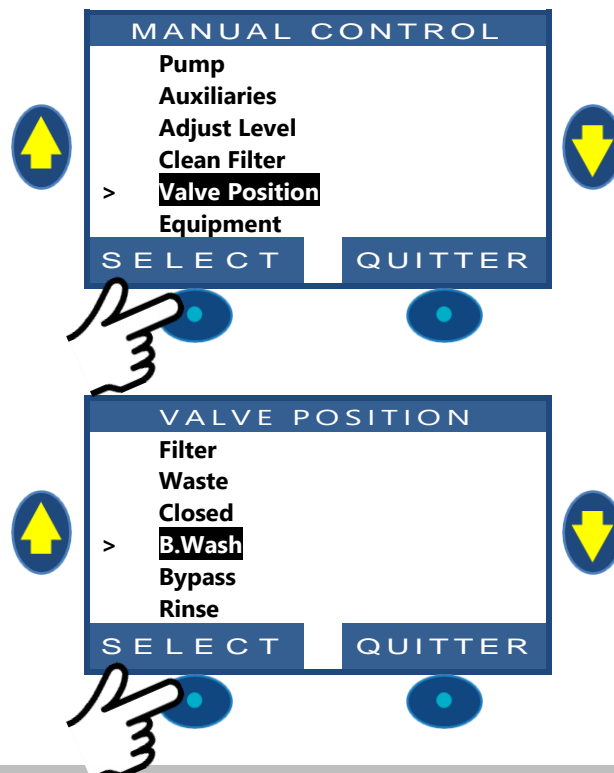

- ❑ Press **SELECT**: **VALVE POSITION** displays.
- ❑ Scroll **UP** and **DOWN**: place cursor at desired valve position.
- ❑ Press **SELECT**: the pump will stop if ON, and the valve will be rotated to the desired position.
- ❑ The pump can now be started as required from the **PUMP** menu.



WARNING:
 In positions Waste, Backwash or Rinse, pool water level will reduce. Water level will continue to reduce until the pump is stopped manually, the next filtration cycle starts or pump loose its prime. Before draining water or reducing level, establish that the quantity of water evacuated poses no risk.

4.4.4.3 Carry out a Clean Filter cycle

Proper filter cleaning ensures that the filter operates very near optimum efficiency; this ensures a clean, healthy pool and greatly reduces running costs. Properly programmed, your PoolCOP will clean the filter when it senses that the filter is getting clogged.

- ❑ To carry out additional Clean Filter cycles, navigate to **MANUAL CONTROL**.
- ❑ Scroll **UP** and **DOWN** to place cursor at **CLEAN FILTER**.
- ❑ Press **SELECT**; a confirmation screen displays.
- ❑ Press **SELECT** again, and a filter cleaning cycle will be carried out.

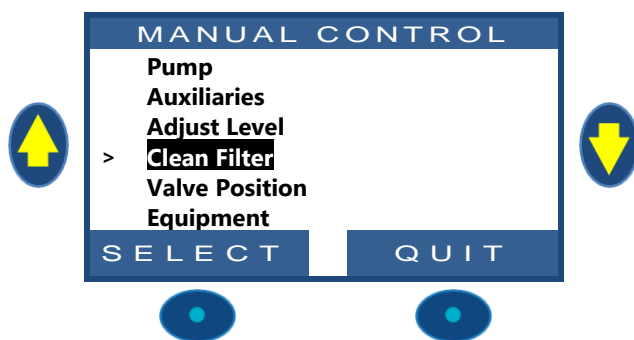

Your PoolCOP now automatically controls the pump and filter system to carry out a backwash and a rinse cycle based on settings programmed. The display will show progress and pressures as your PoolCOP cleans the filter automatically. Once the cycle is complete, the system returns to normal operation.

During the **BACKWASH** phase, to advance to **RINSE** prior to expiration of the programmed duration, press the **RINSE** button.

During the **BACKWASH** phase, the cycle can be interrupted by pressing the **QUIT** button.

During the **RINSE** phase, to terminate the cycle prior to expiration of the programmed duration, press the **QUIT** button.

If filtration was running before cleaning, the pump will automatically switch **ON** when the filter cleaning cycle completes to resume filtration cycle.

4.4.4.4 Understanding Pump Modes

On the PoolCOP main display, next to **Pump** you will see the **mode** in which the pump and filtration are running, or **OFF**. The mode that has started and/or is now causing the pump to be on will be displayed. In this example, the pump is filtering in **AUTO** (see below) and current pressure displayed.

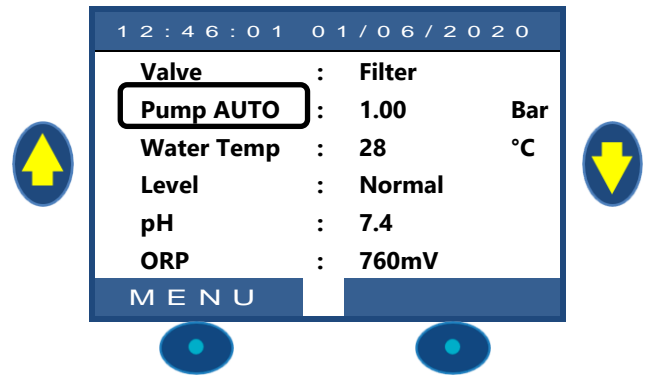

Pump Mode	What's happening now?	Water Treatment	What will happen next?
STOP	The filtration pump is OFF. No filtration cycles are defined.	OFF	The filtration will remain OFF as long as there is no filtration cycle or no manual command to start the pump.
MAN	The pump was started by the user, or by the external run pump command, and is running <u>outside</u> a programmed timer period	OFF	PoolCOP will revert to the programmed filtration cycles when the next timer starts.
TIMER	Filtration was started using user programmed timer settings in Cycle 1 and/or Cycle 2 in TIMER mode and is running inside a programmed timer period.	Active	PoolCOP will use fixed programmed timer settings to start and stop the filtration.
AUTO	Filtration was started by or has now entered the Filtration Timer cycle and is in an automatic mode.	Active	PoolCOP is optimizing the filtration duration based on measured temperature, as well as pool and pump data settings.
FORCE	Filtration is in Mode Forced, which was selected by the user in Manual Operations.	Active	Filtration will run for 23:00 per day for the duration selected (24, 48 or 72 hours). PoolCOP will then revert to the programmed filtration cycles when the next timer starts.
FRZ	Freezing risk detected, and filtration is running to use warmer water from the pool to reduce the risk of the pool or equipment freeing.	Active	30min after freezing risk has cleared, PoolCOP will revert to the programmed filtration cycles when the next timer starts.
PAUSE	Filtration is currently stopped because a filtration cycle ends or a manual command or an event stopped the pump.	OFF	Filtration will automatically restart with the next filtration cycle.
EXT	Filtration has been started because of an external request (via a configured Input).	OFF	Filtration will be running as long the external request is present, although it will respect the 2 x 1/2h pause per day.
LVL	Filtration has been started because of Very High Water level in buffer tank (infinity pools only).	OFF	Filtration will be running until a water level reduction is activated
24/24	Pump is running 24/24.	ON	Pump will run until manually ordered to stop or if priming is loss.

4.4.4.5 Filtration Duration Guidelines

Filtration is the first vital step in managing a pool. Good filtration (the filter and media in good condition and adequate filtration duration) reduces the organic matter and nutrients in the pool water and allows for stable and predictable water treatment. Poor filtration means that even high levels of chemical treatment may be unable to maintain the pool water in safe and healthy condition.



NOTE:

It is recommended to keep at least 60min of free time (no filtration) per day. This will permit pH measurement, and automatic pool refill if installed.



NOTE:

Water treatment (pH and disinfection) will only run if filtration cycles are programmed with at least one of the two filtration cycles set to an appropriate duration.



WARNING:

The filtration mode used will respect local and national code and regulations. In commercial pools 24/24 mode is typically required.

4.4.4.5.1 Filter and Media

Ensure that manufacturer guidelines are followed for the chosen filter and media. Filter and filtration media in poor condition reduce filtration efficiency and increase running cost, whilst risking health due to algae and bacterial growth. Renew or clean the filter media periodically, as recommended by the manufacturer.

4.4.4.5.2 Hydraulic Coefficient

Adequate filtration depends on the hydraulic coefficient of the filtration.

$$\text{Hydraulic Coefficient} = \text{Pool Volume} / \text{Filtration Rate Per Hour}$$

Filtration Rate per Hour is the actual rate of filtered water returning to the pool.

In a correctly designed swimming pool, the hydraulic coefficient will be 4 to 6; a coefficient lower than 4 results in increased energy costs and a coefficient over 6 can result in inadequate filtration. This coefficient can be compensated if above 6 by adding filtration duration.

When calculating filtration duration in all automatic modes, PoolCOP takes the hydraulic coefficient into account and adjusts the filtration duration accordingly.

4.4.4.5.3 Timer Based Filtration

In **TIMER** mode, filtration durations are not managed by PoolCOP but chosen by the end user who must then make sure to correctly set the duration according to pool needs. A too long duration will waste energy and a too short one may not allow to keep the pool in good conditions.

4.4.4.5.4 Temperature Based Filtration

In **ECO+** mode, PoolCOP uses measured temperature to calculate filtration duration. Duration is recalculated daily to optimize filtration:

- Significant savings are made in the off seasons by reducing filtration duration during the cooler months.
- Increased water temperature requires longer filtration time. So, during summer the filtration time is increased, which is very effective at eliminating nutrients which cause bacteria and algae to proliferate.
- Pump (and other equipment) life expectancy is extended, as use and wear is minimized.

4.4.4.5.5 Volumetric Based Filtration

The filtration duration must circulate the pool water at least once during a day.

When automatically calculating filtration duration in **VOLUME** mode, PoolCOP takes entered volumetric turnover data (Pool Volume, Flow Rate, Turnovers) into account and adjusts the filtration duration accordingly.

4.4.4.5.6 Continuous Filtration

With multi speeds pumps and especially when pump is running at low speed, it makes sense to set the filtration to 23 hours per day in such a case, the filtration is not managed by changing the duration but by adjusting pump speed. In **CONTINUOUS** mode, filtration will run 23/24.

4.4.4.5.7 Forced Filtration: 24h, 48h or 72h

PoolCOP normally runs on timers and on automatic modes, adjusting the filtration duration as required. When required however, forced running of the pump in **FILTER** can be selected. This allows a fixed length filtration duration which is useful under certain conditions.

FORCED mode changes Filtration Timer Cycle 1 times. When the forced duration is completed, previous settings for Cycle 1 are restored. This mode does not affect Cycle 2 settings.

In **FORCED** mode, the maximum daily duration is limited to 23:00; with either one or two stopped periods to allow for PoolCOP measurement functions and daily self-test to occur. Normal automatic filter cleaning may occur during **FORCED** mode. Water treatment is active during this mode.

The time remaining in Forced mode is displayed in whole hours on the pump Manual Control screen and on Filtration Mode screen. Any active forced filtration mode is deactivated when the duration has expired, and the Filtration Timer cycles will resume normal control as programmed.

Forced mode can be cancelled by stopping the pump manually or by changing the **filtration mode**.

Stop the Pump

- Navigate to **PUMP** in the **MANUAL CONTROL** menu.
- The pump will be **ON**, and pressure will be displayed.
- Press **SELECT** (**PUMP** is preselected).
- Press **SELECT** (**PUMP: OFF** will display).
- Press **SELECT**. The pump will stop, and pressure will reduce.

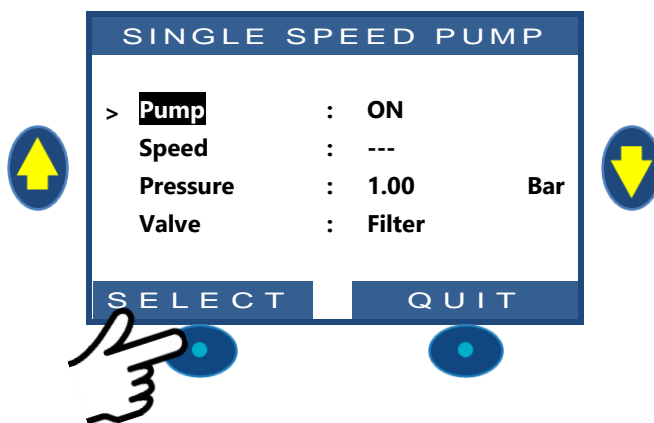

Mode Change

- Navigate to **MODE** in the **FILTRATION MODES** menu.
- The mode will be **FORCE**, remaining time (**18 Hours** in this example) and the subsequent mode (**ECO+** in this example) will be displayed.
- Press **SELECT** (**MODE** is selected).
- Use the ARROWS to change mode.
- Press **SELECT** to validate the new mode.

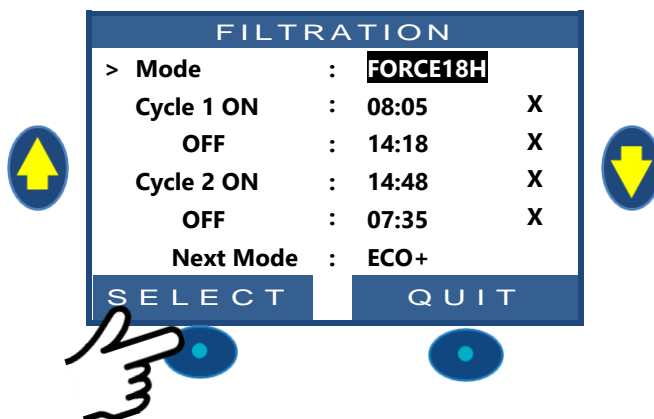

4.4.4.5.8 24/24 Filtration

In commercial pools and low speed filtration pools, filtration must run 24 hours per day due code, regulations or the application. Use the **24/24** mode.



NOTE:
24/24 Mode is required for many commercial pools according to code and regulations.

4.4.4.6 Set and Adjust Filtration

PoolCop allows you to manually or automatically control the filtration duration. See Programming Guide for more information. Whenever quitting the **FILTRATION MODES** menu, PoolCop checks and adjusts the status of the pump and auxiliaries and switches them **ON** or **OFF** as required to match programmed run times.

4.4.4.6.1 Filtration Timers and Modes

- Navigate to **FILTRATION MODES** in the POOLCOP MENU.
- Select the **MODE**.
- Use the **UP** and **DOWN** arrows to adjust the **ON** and **OFF** times.
- Use the **SELECT** button to enter the adjusted value.

Unless using **24/24** mode, it is recommended to set both filtration cycles (Cycle 1 and Cycle 2) for best results. It is recommended to leave a gap of at least 30 minutes between two timer cycles to allow PoolCop to take necessary measurements make subsequent adjustments and carry out the periodic backwash if selected.

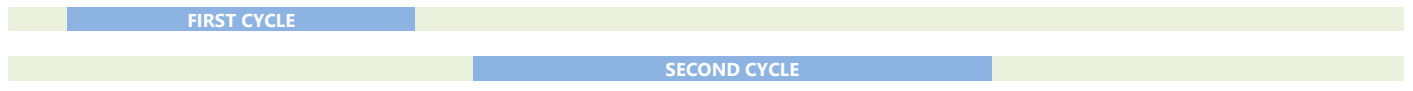
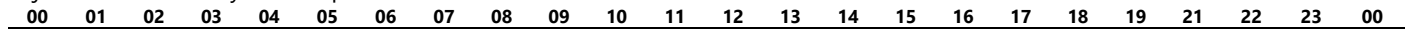

If, however the timers are set to overlap, then the total filtration time will be from the earlier cycle **ON** time until the later timer **OFF** time.

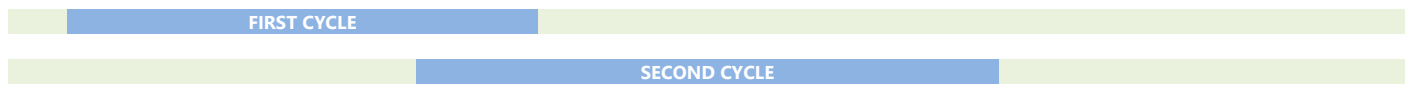

It is **recommended** to never exceed 23:00 per day, to allow PoolCop to take necessary measurements, make subsequent adjustments and carry out the periodic backwash if selected.

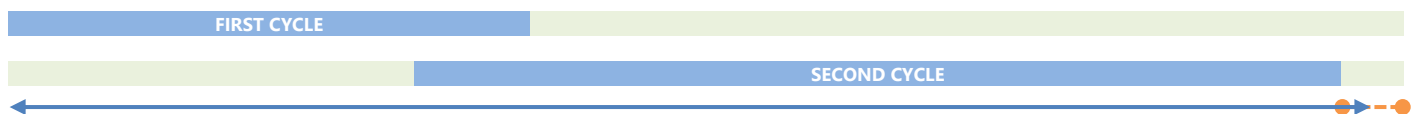

4.4.4.7 Antifreeze Protection

The internal antifreeze protection will start the filtration if low temperatures are detected.

This protects me in areas where running the pool all year round is possible and protects against short periods of cold weather.

Protection Antifreeze can be configured **ON** in the **POOL DATA** menu (the default is **ON**).

Freezing presents risks to pools and pool equipment. Expansion of the water as it moves from the liquid to the solid state can crack pipes and burst fittings, as well as the filter and the pump body.

PoolCOP has two means of detecting a freezing risk. It is recommended that BOTH freezing protections be utilized, and that freezing protection be selected **ON** in the **POOL DATA** menu throughout the year.



CAUTION:

PoolCOP freezing protections can only assist in the protection of equipment. PoolCOP cannot guarantee that damage will be avoided under all circumstances, as this depends on many factors. No responsibility will be accepted for damage caused due to freezing.



NOTE:

When freezing risk is detected and filtration is started, the pump CANNOT be stopped until the temperature detected is higher than the protection setting, or the Protection Antifreeze is switched OFF in the Pool Data menu.

4.4.4.7.1 Internal Freezing Protection (for Pool Equipment)

Internal temperature sensing detects low temperature and starts the filtration to move warmer water from the pool through the plumbing to reduce the risk of damage due to freezing, if the protection is **ON**. This protects equipment in the pump and filter area to a certain degree.

If the Water Temperature Sensor detects a temperature below 2°C (35.6°F), the Alert "**WARN: FREEZING RISK**" will display if freezing protection is **OFF**, or freezing protection will be activated if freezing protection is **ON** in **POOL DATA** menu. For all modes, the filtration will run at all times that the temperature is less than 2°C (35.6°F) and will continue for a period of 30 minutes after the temperature rises above 3°C (37.4°F).

4.4.4.7.2 External Freezing Protection (for the Pool)

There can be great differences in temperature between the pump and filter installation and the pool itself. The optional Air Temperature Sensor is highly recommended so that external air temperature can be used to alert to the risk of freezing and start filtration.

If the optional Air Temperature Sensor is fitted, measured temperature is used to trigger antifreeze protection when temperature is below the desired setting (see 5.5.7). The Alert "**WARN: FREEZE RISK**" will display if protection is **OFF**, or freezing protection will be activated if freezing protection is **ON** in **POOL DATA** menu. For all modes the filtration will run at all times that the temperature is below the threshold and will continue for a period of 30 minutes after the temperature rises above the threshold.

Alternatively, an external thermostat can be installed and connected to an input channel so that external air or water temperature can be used to alert to the risk of freezing and start filtration. When an external thermostat sensor is connected and configured on one of the inputs and detects a temperature lower than the thermostat settings, the Alert "**WARN: FREEZE RISK**" will display if protection is **OFF**, or freezing protection will be activated if freezing protection is **ON** in **POOL DATA** menu. For all modes, the filtration will run at all times that the temperature is less than the trigger temperature set on the external thermostat and will continue for a period of 30 minutes after the temperature rises above the set trigger temperature.



CAUTION:

When freezing risk is detected and filtration is started but pump DO NOT PRIME, the alert "WARN: FREEZE RISK**" will warn the situation cannot be managed by PoolCOP. This requires immediate intervention.**

4.4.5 Water Level Control

4.4.5.1 Automatic Water Level Control

The optional Water Level Kit is required for automatic water level control. The water level controller measures the level when the filtration stops. The water level will be replenished automatically when level is below setpoint (**NORMAL** or **HIGH**) provided that **REFILL MODE** is set to **REFILL** or **AUTO**. The water level controller will only replenish whilst the pump is **OFF**. When the pump starts the valve closes automatically unless continuous filling has been selected. **To allow water level measurement, and for all modes except 24/24, pump should be stop at least 30 minutes between each filtration cycle.**

The water level will be reduced automatically when above setpoint (**HIGH** or **V_HIGH**) level is detected provided that **REFILL MODE** is set to **REDUCE** or **AUTO**. With filter **CLEANING: AUTO**, cleaning cycles will be commanded to reduce the level; with cleaning **INHIBITED** or **MANUAL**, the water is sent to waste.

4.4.5.2 Refill Pool Manually

- ❑ If running, stop the pump in **MANUAL CONTROL**.
- ❑ In the **MANUAL CONTROL** menu, select **ADJUST LEVEL**.
- ❑ Press **SELECT**, then after level reading:
 - If level is below setpoint, the pool refills.
 - If level is above setpoint nothing will happen.

If level is **HIGH** or **V.HIGH** a water level reduction may occur within 15 minutes

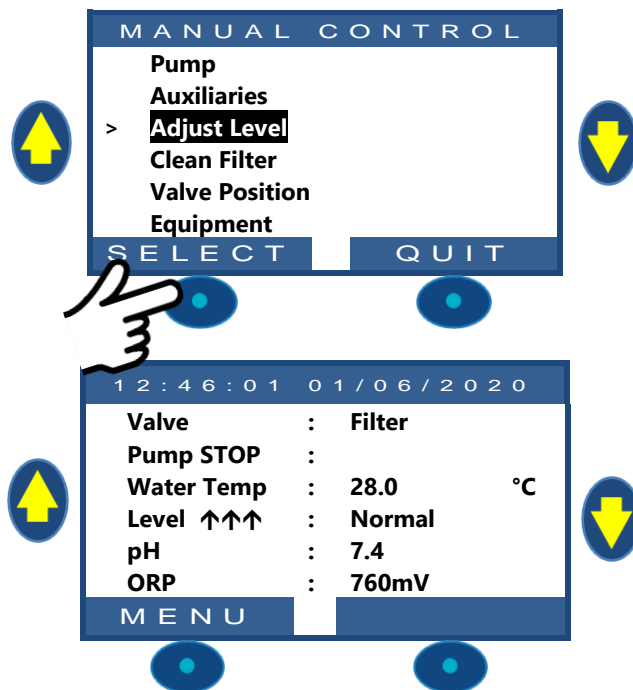

When water refill is ongoing, blinking vertical UP arrows (↑↑↑) are shown on the main screen, close to "Level" text.

If the refill is stopped manually (using Manual control/Pool refill) arrows will be change to dots (•••).

4.4.5.3 Reduce Water Level Manually



CAUTION:
 If draining the pool, remember to switch off automatic refill, and close the water supply at the shut off tap prior to draining the pool even partially. Deactivate filtration timers; deactivate periodic filter cleaning mode.

- ❑ Navigate to **MANUAL CONTROL**
- ❑ Scroll **UP** or **DOWN** to place cursor at **VALVE POSITION**.
- ❑ Press **SELECT**; **VALVE POSITION** will display
- ❑ Scroll **UP** or **DOWN** to place cursor at **WASTE**.
- ❑ Press **SELECT**; the pump will stop (if ON) and the valve will rotate to the **WASTE** position.

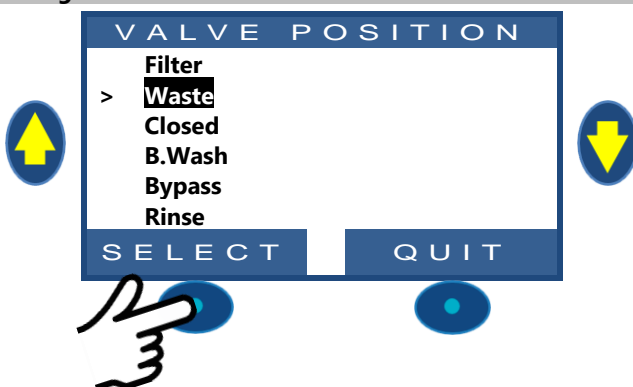

- Start the pump.
- Closely monitor water level, closing skimmers and suction points as required.
- Stop the pump when desired water level is attained.

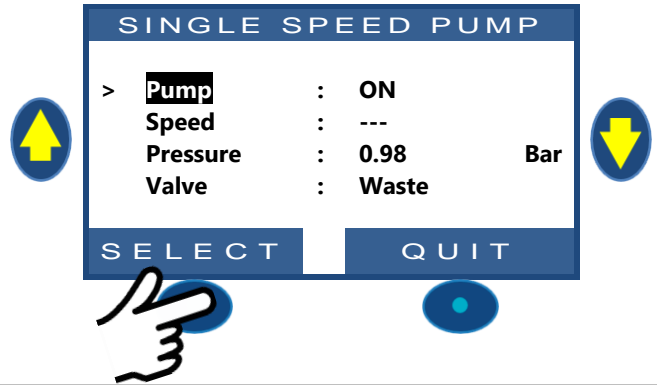

NOTE:
With filter type **Cleaning: AUTO**, it is recommended to use cleaning cycles in Manual Control to reduce water level to economize water consumption.

4.4.6 Water Treatment

See 3.6 Installing Water Treatment.

4.4.7 Auxiliary Control

Auxiliaries have one cycle in every 24-hour period.

Auxiliaries can be set to slave mode i.e. to run only when the filtration runs. It is recommended to use the slave mode for any auxiliary that depends on filtration flow rate (such as heating, cleaners, water treatment, etc.).

Auxiliaries can be set to run on certain day(s) of the week. This is done by choosing days **ON** and days **OFF** within the week.

Setting any timer to 00:00-00:00 (or any combination with same start and stop times) deactivates that timer.

Whenever quitting the **AUXILIARIES** menu, PoolCOP checks and adjusts the status of the auxiliaries and switches them **ON** or **OFF** as required to match programmed running times.

4.4.7.1 Switch Auxiliaries ON/OFF

- Navigate to **MANUAL CONTROL**.
- Scroll **UP** or **DOWN** to place cursor at **AUXILIARIES**.
- Press **SELECT**.

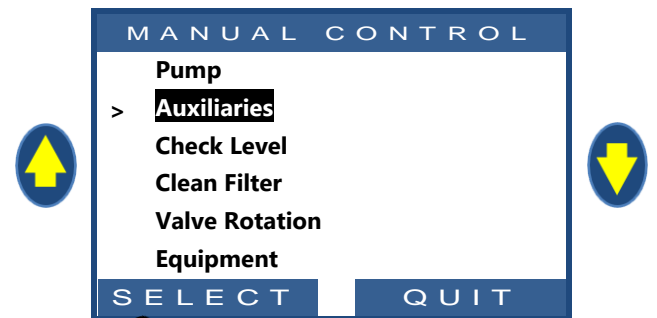

- Scroll **UP** and **DOWN**: place cursor at the desired Auxiliary.
- Press **SELECT**: the auxiliary will switch **ON** or **OFF**.

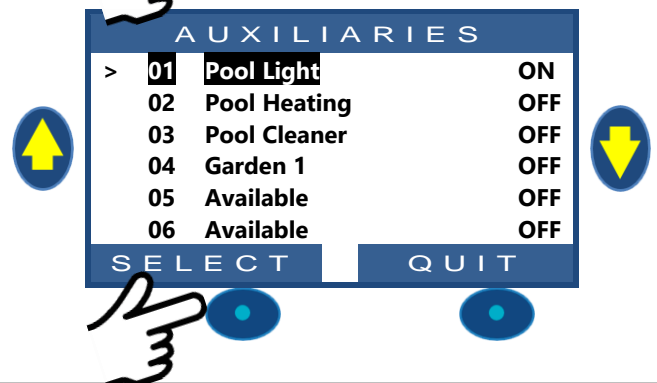

NOTE:
Undefined Auxiliaries (indicated as "Available" cannot be switched ON/OFF. To set an Auxiliary name, see 5.3 Auxiliaries Menu.



NOTE:
If the Auxiliary is slaved to filtration and the pump is not ON or not primed, you will be prompted to start the pump.

If auxiliary is slaved, the pump must be primed before switching the Aux to **ON**. Pump will be declared primed when pump is **ON**, pressure is above the protection pressure setting and flow is detected at the flow switch (if installed).

- To start the pump, press **PUMP** button to jump to the pump command page, otherwise press **QUIT**.

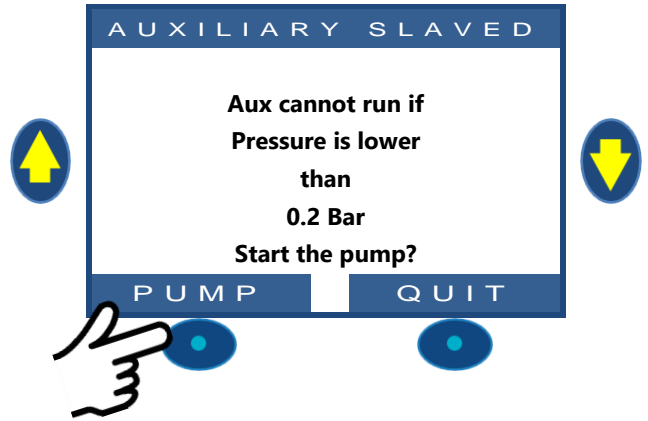

4.4.8 Equipment Control (requires XM8)

Equipment are specific devices such as Pool Cover, JetStream.

- Navigate to **MANUAL CONTROL**.
- Scroll **UP** or **DOWN** to place cursor at **EQUIPMENT**.
- Press **SELECT**.

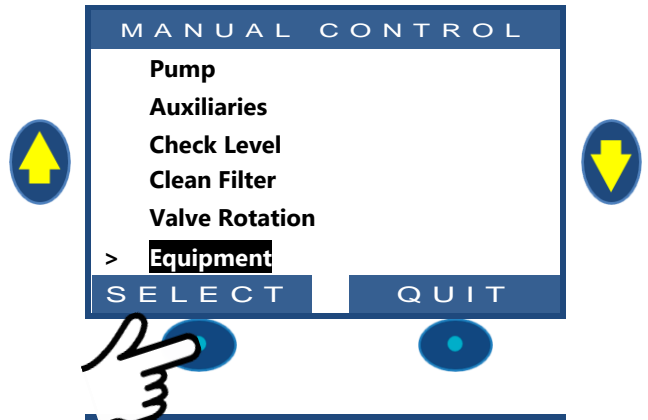

Scroll **UP** or **DOWN** to select the equipment you want to control (depending on the actual configuration)

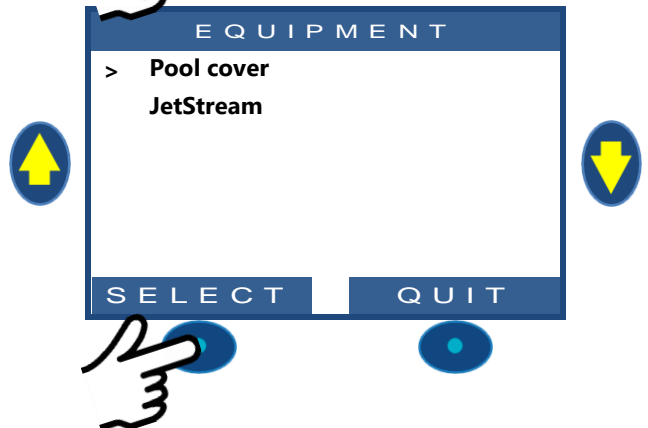

4.4.8.1 Pool Cover

- Scroll **UP** or **DOWN** to select the action to be executed.
- Press **SELECT** to launch the command.

When both commands are **OFF**, the motor is stopped. Actual cover position is shown.

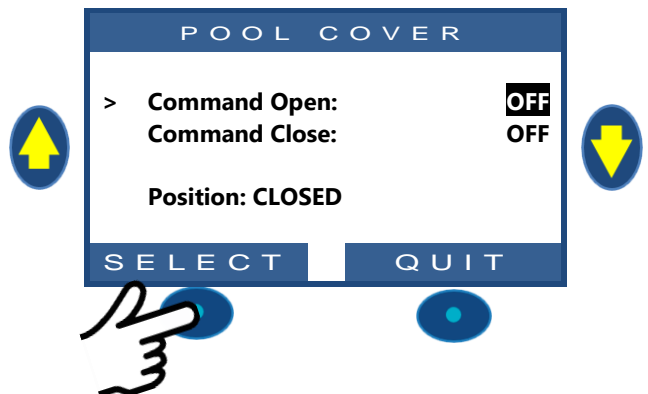

4.4.8.2 JetStream

- Command is preselected.
- Press **SELECT** to start or stop the equipment.

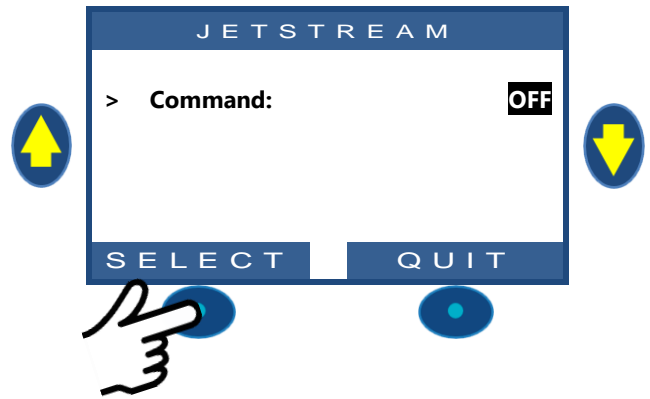

4.4.9 Service Mode

In service mode, PoolCOP stops all automatic actions.

Service mode can be activated directly from the main screen by simultaneously pressing the **UP** and **DOWN** arrows. Every simultaneous action on both arrows will toggle the service mode.

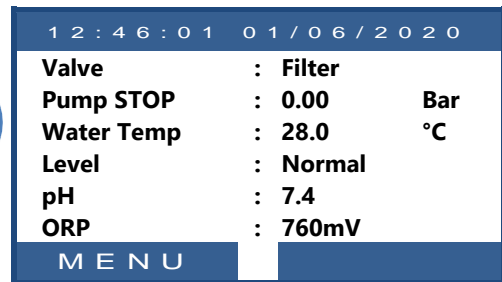

When in service mode, extra service screens are available. These screens display: Pump and Aux statuses, Inputs statuses, and water level status. To display these screens, press either **UP** or **DOWN** arrows. Display will return to main screen after 5 minutes of inactivity.

The first service screen displays pump and Aux statuses.

- Press **UP** to display Auxiliaries and pump status.
- Press **QUIT** to return to main screen

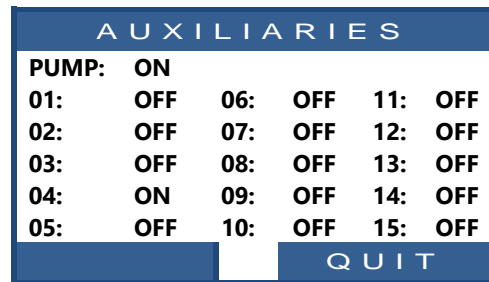

The second service screen displays inputs statuses.

- Press **UP** again to display Inputs.
- Press **QUIT** to return to main screen.

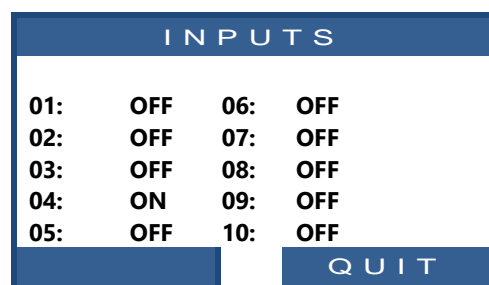

The third service screen displays water level sensor detail.

- Press **UP** again to display water level.
- Press **QUIT** to return to main screen.

Remember that the water level function requires the sensor studs to sense water level (see 3.6.2 Water Level Control). Levels are reported **ON** when they are in contact with water. **(WL) Prot** is the topmost stud. **(WL) High** is the third stud from bottom. **(WL) Low** is the second stud from bottom. **COMM** the common is the lowest stud.

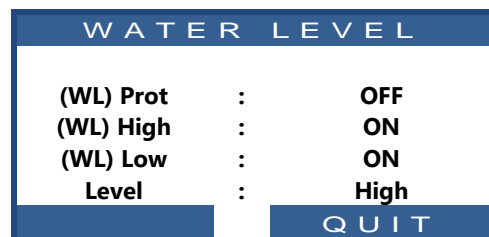

4.5 TROUBLESHOOTING AND ALERTS

4.5.1 General Troubleshooting

4.5.1.1 Pool Water Quality Not Good

- See 2.4 Routine Maintenance.
- See 3.5 Water Treatment.
- Contact the installer for assistance and advice.

4.5.1.2 PoolCOP Unresponsive

If nothing is displayed on the PoolCOP screen, check:

- PoolCOP responsive to buttons.
- Mains power supply connected and PoolCOP switched ON at CCU.
- PoolCOP CCU fuses.
- Contact the installer for assistance.

4.5.1.3 pH or ORP Measurement Unstable or Erratic

Unstable readings of pH or ORP can be caused by a number of factors. Check the following:

- Check for stray micro currents.
- Verify sensor condition and age.
- Contact the installer for assistance.

4.5.1.4 Temperature Indicating Unusually High

Temperature indicating high is caused by a short circuit in the temperature sensor.

- This could be caused by corrosion or by humidity.
- Check for water inside the VDU.
- Contact the installer for assistance.

4.5.1.5 Water Leak Inside Valve Data Unit

If water is found **INSIDE** the Valve Data Unit:

- Check for leaks from the pressure sensor tubes.
- Check for leaks from the pH sensor.
- Check for leaks from the ionizer electrodes or plugs.
- Check if temperature indication is unusually high (see above).
- Contact your installer for assistance.

4.5.1.6 Pool Water Level Low, or Pool Draining

If there is any doubt about the level of the pool water and that the pool may be draining, immediately ascertain the cause:

- Stop filtration.
- Close all valves to prevent further water loss.
- Verify valve position; if not in Filter, select Filter in Manual Operations.
- With valve indicated in position Filter, check waste pipe for water draining out.
- If a manual valve is fitted to the waste pipe, open this to check for draining water.
- If no reason was found, deactivate all timers and contact your installer for assistance.

4.5.2 Electrical Power Failure

Your PoolCop will automatically detect a mains power supply failure and revert to the safe and low power mode, powered by the backup battery.

4.5.2.1 Main AC Power Fails or is Disconnected

- All functions will be de-activated automatically.
- The valve will rotate to the safe position; this critical security function ensures that the valve will always rotate to a safe position to avoid the possibility of flooding the pump house or draining the pool, even in the event of power failure during valve rotation.
- The display on the Valve Data Unit will indicate a power failure.
- The “**Power on**” LED on the Control Connection Unit will extinguish.
- The “**Battery on**” LED remains illuminated to indicate that the battery is functioning.
- The message “AC Power Failure; **PoolCop Deactivated**” is displayed.

4.5.2.2 Main AC Power is Restored Within 5 minutes

- Your PoolCop will immediately reactivate all the functions and timers.
- All parameters will be restored, and no reprogramming of your PoolCop is required.

4.5.2.3 Main AC Power is Not Restored Within 5 minutes

- Your PoolCop will power down completely.
- The display screens will go blank, but no settings will be lost.

When your PoolCop detects that the main AC power supply has been restored:

- Your PoolCop will power up and reactivate all the functions and timers.
- All settings are restored, and no reprogramming of your PoolCop is required.
- The saved history of Clean Filter cycles and Pool Refill are reset to zero.

4.5.3 Alerts and System Messages

An Alert or a System Message is the way PoolCop notifies you of something out of the ordinary.

The **ALERT** button flashes to attract your attention. Alerts can be one of four types:

- REMIND: a task that should be done soon to prevent any deterioration of pool condition.
- WARN: an occurrence or event that needs your attention.
- ERROR: something has gone wrong, but PoolCop is functioning.
- FAILURE: PoolCop has stopped functioning.

Selecting an Alert will allow it to be reset and cancelled, if:

- The alert condition has been rectified.
- The alert condition is not currently active.

An Alert which is still active will re-appear as you leave the alert page, even if reset.

4.5.3.1 Alerts list and troubleshooting



NOTE:

The alerts list, the alerts triggers and the troubleshooting corrective guidelines are detailed in the TROUBLESHOOTING MANUAL downloadable on www.poolcop.com in resources/downloads.

4.5.3.2 View and Reset Alerts

If an alert is active, the **ALERT** button will flash, the number of actives alerts is displayed in brackets.
Pressing the **ALERT** button will display the alert.

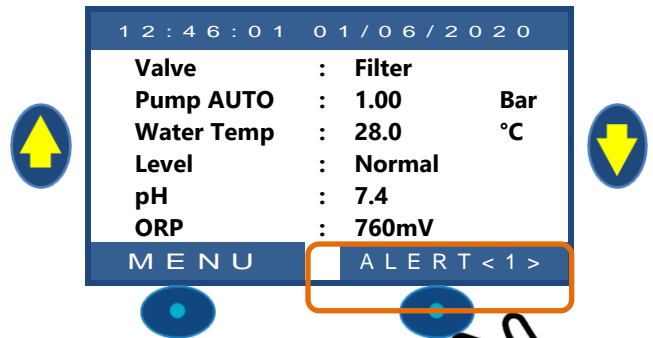

If there are multiple alerts, using the **UP** and **DOWN** arrows scrolls through the alert messages.
Pressing the **RESET** button will reset the displayed alert.

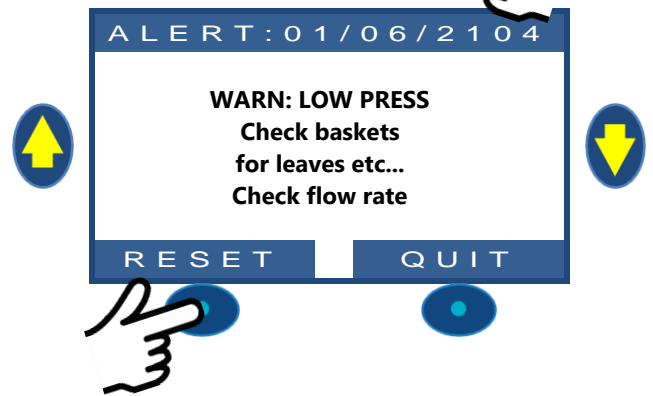

Section 5 PROGRAMMING GUIDE

5.1	Prior to Commencing Programming	89
5.1.1	Clean the Filter	89
5.1.2	Check Water Level	89
5.1.3	Test and Balance Water	89
5.1.4	Understanding Pressure Parameters	89
5.2	Filtration Mode Menu	90
5.2.1	Mode	90
5.2.2	Cycle 1 Times	91
5.2.3	Cycle 2 Times	91
5.3	Auxiliaries Menu	92
5.3.1	Auxiliary ID	92
5.3.2	"Aux" Mode	93
5.3.3	"Aux" Times (Timer Mode)	93
5.3.4	"Aux" Time and Duration (Pulse Mode)	93
5.3.5	"Aux" Heating Temperature (Filtration/Priority/Schedule Modes)	93
5.3.6	"Aux" Slave	94
5.3.7	Aux Days of the Week	94
5.4	Water and Treatment Menu	95
5.4.1	Water Level	95
5.4.2	pH Control	98
5.4.3	ORP Control	100
5.4.4	Remnant Injection	102
5.4.5	ACO Injection	103
5.4.6	Free Available CL	103
5.5	Maintenance	104
5.5.1	Service Mode	104
5.5.2	Measure pH	104
5.5.3	Calibrate pH	104
5.5.4	Value FAC	105
5.5.5	Calibrate FAC	105
5.5.6	Calibrate Conductivity)	105
5.5.7	Air Anti-Freeze	105
5.5.8	Stop Water Treatment	105
5.5.9	Adjust Water Temperature	105
5.6	Configuration Menu	106
5.6.1	Pool Data	106
5.6.2	Pump Data	108
5.6.3	Filter Data	110
5.6.4	Inputs	113
5.6.5	Energy Meter	116
5.6.6	Equipment	117
5.6.7	Factory Settings	120
5.7	PoolCOP Cloud	122
5.7.1	Connected	122
5.7.2	Registered	122
5.7.3	OTP Code	122
5.7.4	UUID	122
5.8	Set PIN Code	123
5.8.1	Activated	123
5.8.2	PIN Code	123
5.8.3	Confirm	123
5.9	Circulation Modes	124
5.9.1	ECO Mode	124
5.9.2	Setpoint	124
5.9.3	Bottom cycle	124

5.1 PRIOR TO COMMENCING PROGRAMMING

5.1.1 Clean the Filter

Ensure that the filter media is properly maintained and cleaned as per the manufacturer's instructions and code requirements.

5.1.2 Check Water Level

Refill the pool to the normal level, to ensure accurate pressure and other readings.

5.1.3 Test and Balance Water

It is strongly recommended that the pool water be analyzed and balanced prior to programming any water treatment features.

5.1.4 Understanding Pressure Parameters

Pressure management is used widely to control filtration management. Settings are defined in:

- Pump Data Menu (see 5.6.2 Pump Data)
- Filter Data Menu (see 5.6.3 Filter Data)

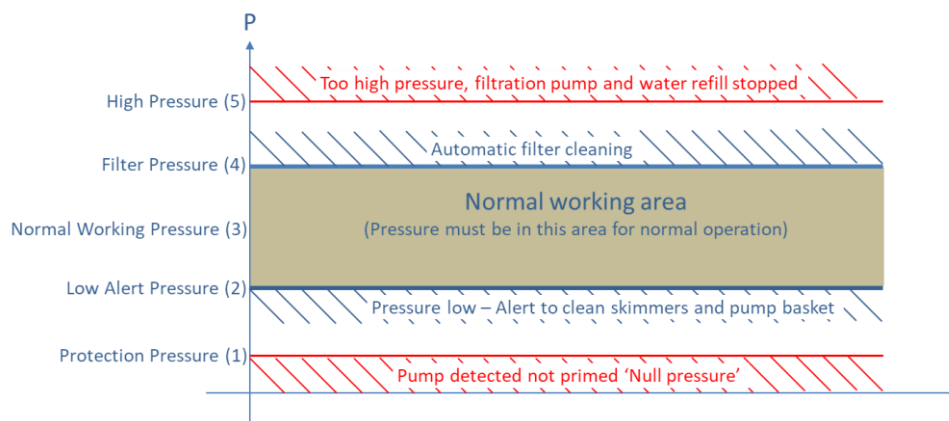

Figure 80 - Pressure setting parameters.

- **(1) Protection Pressure (Pump Data):** Determines if pump is primed or not.
 - Check if pump is primed or not. When pressure is below Protection Pressure, pump is considered not primed. Pump protection will be triggered after 8 minutes if pressure remains below Protection Pressure and if protection is set ON.
 - Allow valve rotation. Valve rotation will be inhibited or stopped if pressure is above protection pressure. It's a protection for the valve diffuser.
- **(2) Low Alert Pressure (Pump Data):**
 - Pump is considered primed but with low efficiency due low pressure/flow.
 - An alert will be triggered if pressure is below Protection Pressure when the pump is running.
 - Alert message proposes cleaning skimmer baskets and pump pre-filter strainer.
- **(3) Normal Pressure:** Determines the normal working pressure range of the pump.
 - For best results, pressure must be in this area when filtration is running.
 - With variable speed pumps, all speeds (except filter media cleaning speed) must be within this range.
- **(4) Filter Cleaning Pressure (Filter Data):** Determines the pressure at which filter media cleaning is required.
 - If pressure is at or above this value for 5 minutes continuously, an alert to clean the filter is triggered.
- **(5) High Pressure (Fixed Value):** fixed 1.9 bar (27.5 PSI) value to protect pump, filter and other equipment's in the pump house. In all modes the pump and water refill (if installed) will stop immediately, and an alert message is triggered.

5.2 FILTRATION MODE MENU

Set the duration and times for daily filtration.

The filtration timer has two cycles in any 24-hour period, Cycle 1 and Cycle 2; these cycles are pre-set or are available for any setting depending on the filtration mode selected.

When using **24/24** mode operation does not use timer cycles.

FILTRATION	
> Mode	: ECO+
Cycle 1 ON	: 02:30
OFF	: 06:45
Cycle 2 ON	: 12:00
OFF	18:43 X
SELECT QUIT	



NOTE:

When using filtration cycles, it is recommended to keep at least 30min of time OFF between cycles. This will permit pH measurement, periodic filter cleaning, and automatic pool refill if installed.

5.2.1 Mode

There are 8 modes of operation:

- In **STOP** mode, filtration timers are set to **00:00**. The filtration will never run in automatic mode.
- In **TIMER** mode, filtration Cycle 1 and Cycle 2 times are set by the user.
- In **ECO+** mode, PoolCOP adjusts filtration duration based on measured water temperature, filtration rates, and other factors. This mode allows PoolCOP to automatically adjust the filtration duration based on changing seasonal and weather conditions and thus protect water when temperature is high and save energy if temperature is low.
 - Set Cycle 1 as desired. Duration will be taken into account when calculating Cycle 2 duration.
 - Set the Cycle 2 Filtration **ON** time. PoolCOP calculates and sets the **OFF** time, with **X** indicated.
 - The duration is automatically calculated based on the average measured temperatures during filtration in the last 24-hour period.
 - Other pool data settings, including pool volume and rate, are used to correct calculated duration to ensure that adequate filtration is carried out daily.
- VOLUME** mode is based on the same model as **ECO+** Mode with a noticeable difference:
 - In **ECO+** Mode, the filtration duration is calculated is made using the pool temperature.
 - **VOLUME** Mode does not take temperature into account, but simply use the turnover rate defined in the Pool data menu to estimate the filtration time.
- In **CONTINUOUS** mode, Cycle1 and Cycle 2 have the same 11:30 duration time so that the global filtration is 23/24. The only available setting is the starting time of Cycle1.
- In **FORCE** mode (24H, 48H or 72H) filtration will run 23/24 for the selected period and will then revert back to the previous mode. Forced mode is achieved by temporarily setting Cycle 1 timer value so that, added to Cycle 2, the filtration duration is 23 hours. No timer settings are available in Forced mode.
- In **24/24** mode, pump is running continuously, assuming that the pump is correctly priming and pressure ABOVE Protection Pressure.

Text:

Default: STOP
Modes: STOP;
 TIMER;
 ECO+;
 VOLUME;
 CONTINUOUS;
 FORCE24H;
 FORCE48H;
 FORCE72H;
 24/24



NOTE:

ECO+ Mode uses the daily average water temperature to calculate filtration duration. After a Factory Reset the default filter time is approximately 8 hours, based on an assumed temperature of 20°C (68°F). An updated calculation is performed automatically at 17:00.

**NOTE:**

The first time **ECO+** mode is selected, the duration of Cycle 2 will default to 8 hours. Once the filtration has run for approximately 10 minutes an accurate measurement of pool water temperature will enable your PoolCOP to update the filtration duration.

5.2.2 Cycle 1 Times

Filtration timer Cycle 1 is used to set fixed duration filtration **ON** and **OFF** times.

If Cycle 1 **OFF** time falls within Cycle 2 duration, the filtration will not stop but continue until the end of Cycle 2.

Text:	Cycle 1
Default:	00:00-00:00
Entries:	00:00-23:59

5.2.3 Cycle 2 Times

Filtration timer Cycle 2 is used to set fixed duration filtration **ON** and **OFF** times.

If Cycle 2 **OFF** time falls within Cycle 2 duration, the filtration will not stop but continue until the end of Cycle 1.

Text:	Cycle 2
Default:	00:00-00:00
Entries:	00:00-23:59

5.3 AUXILIARIES MENU

Operation Modes of auxiliaries are related to auxiliary names. Auxiliary timers have one cycle in any 24-hour period. When quitting the **AUXILIARIES** menu, PoolCOP checks the status of the auxiliaries, and switches them **ON** or **OFF** as required to match programmed running times.

AUX01: Pool Cleaner	
> Mode	: Timer
ON	: 02:30
OFF	: 06:45
Slave	: NO
Weekday	: xxx✓✓✓✓
SELECT QUIT	

5.3.1 Auxiliary ID

The default auxiliary ID is the **Aux** number. The following 15 pre-set names are available for auxiliaries.

Text:	AUX
Default:	Available
Entries:	Available; Pool Light; Pool Cleaner; Pool Heating; Disinfection; Salt; Remnant; Transfer pmp; UV; Spa; Fountain; Bore Hole; Pool House; Garden 1; Garden 2; Garden 3



NOTE:
On "rimflow" pools (see 5.6.1.6 Pool Type), an auxiliary whose identifier is "Transfer Pump" is considered to be a means of moving the water from the buffer tank to the pool. The pump controlled by this auxiliary will be set ON automatically during the water level control phases in order to produce a change on the water level in the buffer tank.



NOTE:
To change the auxiliary Id, use the up arrow to place the cursor in the title area, then press select to open the scroll list. Use up and down arrow to select the Id label and pre-set select to validate.



NOTE:
Each auxiliary can be renamed on the web application for ease of use and identification via remote interfaces. The name is unchanged on PoolCOP.

5.3.2 "Aux" Mode

Manual mode allows manual **ON/OFF** commands only. No automatic function will apply.

Timer mode allows to define a start time and a stop time.

Pulse mode allows to manage the **ON** duration. When the Aux is set **ON** (manually or automatically) it will revert to **OFF** after the defined duration.

When auxiliary is set as heating, 3 additional modes are available:

In **Filtration** mode, the heater can only operate during programmed filtration hours.

In **Priority** mode, the filtration pump is forced on for priority heating which will accelerate the increase of water temperature.

In **Schedule** the operation of the heater is limited within the period defined by its own timers. Heating will then only be possible within the defined **ON/OFF** time range and if the filtration is running.

Text:	Mode
Default:	Manual
Entries:	Manual; Timer; Pulse; Filtration; Priority; Schedule;

The table below summarizes the available modes according to the auxiliary's identifier:

	Available	Pool Light	Pool cleaner	Pool Heating	Disinfection	Salt System	Remnant	Transfer Pump	UV	Spa	Fountain	Bore Hole	Pool House	Garden 1	Garden 2	Garden 3
Manual		X	X	X	X	X	X	X	X	X	X	X	X	X	X	X
Timer		X	X		X	X	X	X	X	X	X	X	X	X	X	X
Pulse		X	X		X		X			X	X	X	X	X	X	X
Filtration				X												
Priority				X												
Schedule				X												

5.3.3 "Aux" Times (Timer Mode)

In **Timer** mode, set fixed duration with **ON** and **OFF** times.

Setting any timer to 00:00-00:00 deactivates that timer.

Text:	ON/OFF
Default:	00:00-00:00
Entries:	00:00-23:59

5.3.4 "Aux" Time and Duration (Pulse Mode)

In **Pulse** mode, define the ON time.

ON time set to 00:00 suppresses automatic pulse generation. Aux must be set **ON** manually and will fall back to **OFF** automatically after pulse duration.

When in **Pulse** mode, define the duration, up to 99 minutes and 59 seconds.

Text:	ON
Default:	00:00-00:00
Entries:	00:00-23:59
Text:	Duration
Default:	00:00:00
Entries:	00:00:00-00:99:59

5.3.5 "Aux" Heating Temperature (Filtration/Priority/Schedule Modes)

Set the desired temperature of water.

The temperature will be maintained ± 0.1 °C (± 0.18 °F) of the set point.

Text:	Temp
Default:	25°C (77°F)
Entries:	2°C - 40°C (35.6°F - 104°F)

5.3.6 "Aux" Slave

Auxiliaries can be set to run only if:

- The pump is primed (**SLAVE: PUMP**). This is essential for equipment requiring a water flow, such as a robot, water treatment, etc.
- The cover is open (**SLAVE: COVER**). This function only applies to the pool light.

Text:	Slave
Default:	No
Entries:	No; Pump; Cover



NOTE:

When an auxiliary used for-heating it is automatically configured as slave.

5.3.7 Aux Days of the Week

Auxiliaries can be set to run only on selected days of the week.

This is ideal for equipment such as pool cleaners and irrigation, which can be run on specific days of the week.

Text:	Weekday
Default:	ON (ALL)
Entries:	Mon; Tue; Wed; Thu; Fri; Sat; Sun

5.4 WATER AND TREATMENT MENU

Water level, pH and disinfection and other treatment settings.



5.4.1 Water Level

Set water level control parameters. PoolCOP can be configured to automatically refill water level.

When measuring the water level, the last known value blinks on the screen. No action will be taken until the level is refreshed (displayed level value will stop blinking).

An update is performed every 15 minutes when the pump is stopped and if pump is controlled by filtration cycles.

When using 24/24 mode, water level is checked every hour

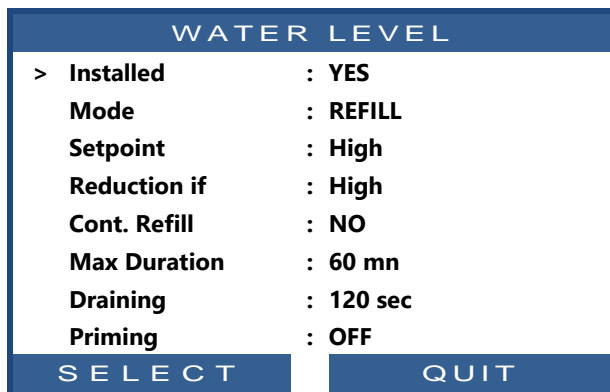

NOTE:
 When using filtration cycles ensure at least 30 minutes between cycles.
 When using 24/24 mode, water level is checked every hour.

5.4.1.1 Installed

With **INSTALLED: YES** the menu options display and alerts are activated.

Text:	Installed
Default:	NO
Entries:	YES; NO

5.4.1.2 Water Level Control Modes

With mode: **READ**, PoolCOP will indicate the water level on the screen but will not take any action to control it. Should the level be **LOW** or above setpoint, an alert will be displayed.

With mode: **REFILL**, if the level is below the setpoint, the refill system commands the supply valve to open to refill the pool until the setpoint (**NORMAL** or **HIGH**) is detected. If the level is above setpoint, an alert will be displayed but the level will not be reduced.

When using filtration cycles, if the pump starts during refill, the valve will close, and refilling will be postponed until the next pump **OFF** period unless **CONT. REFILL: YES**, in which case pool refilling will continue with the pump running.

With mode: **REDUCE**, level will be automatically reduced if above setpoint (**HIGH** or **V_HIGH**). If the level is below setpoint, an alert will be displayed but pool will not be refilled.

With mode: **AUTO**, control combines **REFILL** and **REDUCE** functionalities.

When using 24/24 mode, water level is checked every hour. Refill may start immediately but will be paused after 30 min, to allow for treatment, and will then continue after completed.

Text:	Mode
Default:	Read
Entries:	Read; Refill; Reduce; Auto

5.4.1.3 Setpoint

Define the targeted level during refill.

- Normal:** the second slot of the sensor is targeted.

Text:	Setpoint
Default:	High

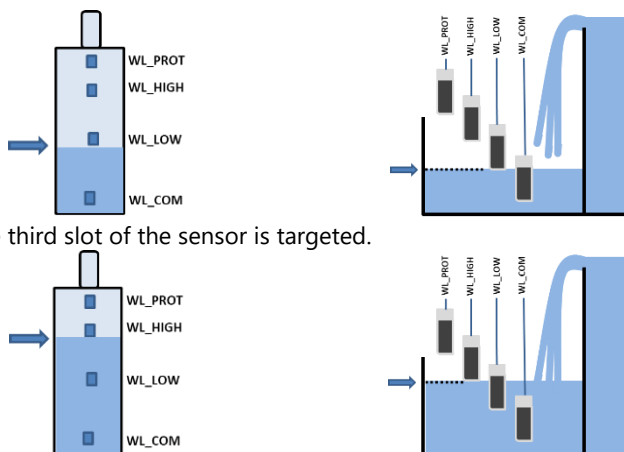

□ **High:** the third slot of the sensor is targeted.

Entries:	High; Normal
-----------------	-------------------------

5.4.1.4 Réduction if

Appears only when the setpoint is set to "Normal" and for "Reduce" or "Auto" control modes.

Selects whether reduction is activated at "high" or "very high" level.

When the setpoint is "High", reduction is activated at "Very High".

Text:	Reduction if
Default:	High
Entries:	High; V.High

5.4.1.5 Continuous Refill

This setting is displayed if mode: **REFILL OR AUTO**.

To avoid pool water flowing back in the water supply circuit, pool refill is normally inhibited when the pump is running. During pool refill if the pump is started manually or with a timer or mode, pool refill is suspended until pump is stopped again. With **CONT. REFILL: OFF** water refill stops whenever the pump starts.

In some installations (such as with low flow rate filtration) pump running time does not allow enough free time to adequately refill the pool. In such cases, **CONT. REFILL** allows refilling whilst the pump is running. With **CONT. REFILL: YES** once started the refill will continue until the water level is **HIGH**, even if the pumps start.

Text:	Cont. Refill
Default:	NO
Entries:	YES; NO



WARNING:

With **REFILL CONT: YES** a poor installation or a defective non-return valve could allow pool water to enter the water supply. This poses a health risk and may only be used if the house water supply is separate from the pool water supply.



NOTE:

When using **24/24** mode Continuous Refill mode is used.

5.4.1.6 Maximum Duration

This setting is displayed if mode: **REFILL**.

Use the **MAX DURATION** parameter to limit the time (and hence water volume) added to the pool during a refill operation. This protects against excessive water consumption in case of significant pool leaks.

The **MAX DURATION** is a daily timeout for pool refill. If reaching the maximum duration during a 24-hour period, refill stops until the following day and an alert is sent advising of this condition. Check for possible leaks or low water supply pressure. The Alert is reset at midnight and another refill can be commanded the following day.

If this situation occurs **on 3 consecutive days**, refill will be **inhibited** until the alert is cleared manually.

Text:	Max Duration
Default:	60min
Entries:	10 - 720min

5.4.1.7 Bottom Force

This setting is displayed for Skimmers pools with suction valve only. Define how long the water circulation is forced via the bottom drain after a backwash. This setting is important with slim skimmers to avoid loss of pump priming, allowing the pool to refill before turning the suction from skimmers.

Text:	Bottom Force
Default:	10min
Entries:	10 to 120min

5.4.1.8 Draining

This setting is displayed if mode: **REDUCE, AUTO**. Set the duration for the water reduction cycle; If the level is detected above setpoint, then PoolCOP will reduce water level following this logic:

- With skimmers pools, reduction will be launched if level sustains above setpoint for 15 minutes.
- With rimflow pools, pump will be started immediately when level is detected above setpoint and will run until either:
 - Level returns **NORMAL**
 - Level stays above setpoint for 15 minutes, which will launch a water level reduce cycle.
 - Level stays at setpoint for 3 hours, which will also launch a water level reduce cycle.

Up to three cycles will be carried out per day.

Text:	Draining
Default:	120 seconds
Entries:	10 – 600 seconds

5.4.1.9 Priming

Ensure Solenoid valve is correctly connected and powered. Commanding priming ON will activate the SOV for 60 seconds allowing the water to flow. Priming is stopped when quitting the menu or after 60 seconds.

Text:	Priming
Default:	OFF
Entries:	ON; OFF

5.4.2 pH Control

Set pH control parameters.
Menu can scroll up and down using the arrow buttons.

pH CONTROL	
> Installed	: YES
Mode	: pH-
Low Alert	: 6.9
High Alert	: 8.2
Max Dosing	: 5 mn
SetPoint 24°	: 7.4
SetPoint 18°	: 7.5
Temp Adjust	: YES
Priming	: OFF
SELECT QUIT	



NOTE:
When using filtration cycles ensure at least 30 minutes between cycles to allow for pH dosing and measurement.
In **24/24** filtration mode pH is measured once per hour and dosing may start immediately after measurement.

5.4.2.1 Installed

If **INSTALLED: YES** PoolCOP will control the pH according to set point value. pH Control display will be activated; pH Control Alerts will be activated.
If set to **NO**, these functions are deactivated.

Text:	Installed
Default:	NO
Entries:	YES; NO

5.4.2.2 Mode

Set the pH Control to reduce or increase pH using the appropriate chemicals.

- READ:** if the pool has a standalone pH control system or if you do not want to control pH but get a reading.
- PH-:** if pH Minus liquid is used.
- PH+:** if pH Plus liquid is used.

Text:	Mode
Default:	Read
Entries:	Read; pH+; pH-

5.4.2.3 Setting Low Alert

Allows to define the value to trigger low alert message.

Text:	LOW Alert
Default:	7.1
Entries:	6.0 - 7.5

5.4.2.4 Setting High Alert

Allows to define the value to trigger high alert message.

Text:	HIGH Alert
Default:	7.7
Entries:	7.5 - 9.5

5.4.2.5 Max Dosing

MAX DOSING acts as a security to prevent inadvertent overdosing, initially calculated with pool volume, can be adjusted. This setting is higher with bigger pools, and with higher water alkalinity; this setting is lower with larger feeder pumps.
MAX DOSING is limited to 15 minutes in **24/24** and filtration mode.

Text:	Max Dosing
Default:	5+Pool Volume/4
Entries:	1 - 30 min

5.4.2.6 Setpoint

Set the desired pH value.

The ideal Setpoint varies with water treatment options, and according to refill water types.

Note: Actual Setpoint will be automatically corrected according to the actual water temperature if **TEMP ADJUST** is set to YES (see 5.4.2.8).

Text:	SetPoint 24°C (SetPoint 75.2°F)
Default:	7.4
Entries:	6.5 - 8.0



NOTE:

**Recommended pH is 7.2 to 7.6 depending on water balance.
See code and regulations for recommended setting.**

5.4.2.7 Setpoint at Current Temperature

PoolCOP can automatically adjust the actual pH Setpoint as a function of temperature to ensure year-round optimal water treatment. This adjusted Setpoint is displayed against the current water temperature if **TEMP ADJUST** is set to YES. This corrected Setpoint is the actual value of pH the PoolCOP will aim to maintain.

Text:	SetPoint xx °C (SetPoint xx °F)
Display of Data only	

5.4.2.8 Temp Adjust

pH setpoint can be auto adjusted by water temperature to respect water balance equilibrium.

If set to YES, targeted pH setpoint will be decreased by 0.1 when water temperature increases by 5°C (9°F).

If set to NO, pH setpoint will not be adjusted.

Text:	Temp Adjust
Default:	YES (EU), NO(US)
Entries:	YES; NO



NOTE:

**pH Temp Adjust will change the actual setpoint.
If code and regulation compliance is required, Temp Adjust is not recommended.**

5.4.2.9 Priming

Ensure feeder pump is connected to Aux7 and correctly powered.

Commanding priming ON will activate Aux7 for 60 seconds allowing the feeder pump to prime. Priming is stopped when quitting the menu or after 60 seconds.

Text:	Priming
Default:	OFF
Entries:	ON; OFF

5.4.3 ORP Control

Set disinfectant parameters based on ORP control.

ORP CONTROL	
> Installed	: YES
Disinfectant	: Chlor
Setpoint	: 760 mV
Boost on	: Mon
Boost to	: 760 mV
Priming	: OFF
Ocean Diag	
SELECT QUIT	

5.4.3.1 Installed

If **INSTALLED: YES**, PoolCop will control the ORP according to set point value. ORP Control display will be activated; ORP Control Alerts will be activated. If set to **NO**, these functions are deactivated.

Text:	Installed
Default:	NO
Entries:	YES; NO

5.4.3.2 Disinfectant

Set the disinfection option and algorithms used.

- READ** Read and display only; no control.
- CHLOR** Chlorine dosing.
- SALT** External Salt System control.
- BROMI** Bromine dosing.
- OCEAN** For PoolCop Ocean salt chlorinator.
- SPACE** For Dryden Aqua Space salt chlorinator.
- DA-GEN** For DA-GEN Hydrolysis system.

Text:	Disinfectant
Default:	Read
Entries:	Read; Chlor; Salt; Bromi; Ocean; Space; DA-GEN

5.4.3.3 Setpoint

Set the desired ORP value; a typical Setpoint is 650 to 760. The ideal Setpoint varies with water treatment options, and according to refill water types.

Text:	Setpoint
Default:	760mV
Entries:	300 - 990mV



NOTE:
Minimum recommended ORP is 650mV to reduce risk of sensor fouling.
See code and regulations for recommended setting.

5.4.3.4 Boost On

If hyper-chlorination is desired, set a day of the week.

Text:	Boost On
Default:	None
Entries:	Mon; Tue; Wed; Thu; Fri; Sat; Sun

5.4.3.5 Boost To

If a day of the week is set for hyper-chlorination, set the desired the ORP value. The Boost To value cannot be lower than Setpoint.

Text:	Boost To
Default:	760mV
Entries:	Setpoint - 990mV

5.4.3.6 Polarity inversion

for disinfection carried out by an OCEAN, SPACE or DA-GEN chlorinator only.
Used to define the operating time before polarity inversion on the plates. This parameter must be adjusted according to the hardness of the water to limit scaling of the plates: reduce the time for "hard" water, increase for "soft" water.

Caution: Too short durations reduce the lifespan of the plates.

Text:	Polarity Inv
Default:	240 min
Entries:	60 min; 720 min

5.4.3.7 Production

If disinfection is carried out by an OCEAN, SPACE or DA-GEN chlorinator only.

Used to adapt the production power of the chlorinator.

When there is less demand for disinfection (outside the peak season), reducing the production power increases the lifespan of the plates.

Text:	Production
Default:	100%
Entries:	10%; 100%

5.4.3.8 Priming

Ensure feeder pump is connected to Aux6 and correctly powered.

Commanding priming ON will activate Aux6 for 60 seconds allowing the feeder pump to prime. Priming is stopped when quitting the menu or after 60 seconds.

With PoolCOP Ocean , priming is progressive. Display will not go from OFF to ON but may stay for a while in '...'. This just shows that production has been requested and is ramping up. When the ramp up is achieved, display should go to 'ON'. If it is not the case, please see diagnostics below.

Text:	Priming
Default:	OFF
Entries:	ON; OFF

5.4.3.9 Diag Ocean (if PoolCOP Ocean, Space or DA-GEN Connected)

See PoolCOP Ocean Guide.

5.4.4 Remnant Injection

Set Remnant parameters.

If possible, Remnant will be injected 1 hour before the end of the latest filtration cycle of the day. If there is no filtration cycle long enough, the longer cycle will be chosen, but the volume actually injected may not fit the requirements.

When Filtration Mode is **24/24**, injection will be set so that it ends at 10PM and re-calculated each day at midnight.

REMNANT INJECTION	
> Installed	: YES
Aux Channel	: Aux2
Inj. Rate	: 1.5 l/h
Temp adjust	: YES
Extra adjust	: Med
Priming	: OFF
SELECT	QUIT

5.4.4.1 Installed

If **INSTALLED: YES**, PoolCOP will control the Remnant injection according to parameters settings.

If set to **NO**, this function is deactivated.

Text:	Installed
Default:	NO
Entries:	YES; NO

5.4.4.2 Aux Channel

Define the channel used to inject remnant.

Any available channels can be used.

Text:	Channel
Default:	Any available channel
Entries:	Aux1, etc.

5.4.4.3 Injection Rate

Set the feeder pump injection rate. Combined with pool volume (**POOL DATA** menu), the injection rate will be used to calculate the remnant injection duration.

Temperature	Volume Injected Per Day	Liquid Chlorine 12% Increase of ppm
20°C (68°F)	6 ml/m ³	+0.72 ppm
26°C (79°F)	9 ml/m ³	+1.08 ppm
30°C (86°F)	12 ml/m ³	+1.44 ppm

Text:	Inj. Rate
Default:	1.5 l/h (9.5 GPD)
Entries:	0.1 - 9.9 l/h (0.63 - 62.8 GPD)

5.4.4.4 Temperature Adjustment

Choose **YES** if the injected volume has to be corrected according to pool water temperature.

If Yes, adjustment occurs between 24°C and 30°C (75.2°F and 86°F).

At 30°C (86°F), the injected volume is 2 times higher.

Text:	Temp. Adjst
Default:	YES
Entries:	YES; NO

5.4.4.5 Extra Adjustment

Add an extra adjustment parameter applying a coefficient to the calculated volume as follow:

LOW: Coefficient is 0.5 (half the volume, for example for indoor pools)

MEDIUM: Coefficient is 1.0

HIGH: Coefficient is 1.5 (1.5 times the volume, for high consumption pools)

Text:	Extra Adjust
Default:	Med
Entries:	Low; Med; High

5.4.4.6 Priming

Ensure the feeder pump is connected to chosen Aux and correctly powered.

Commanding priming **ON** will activate the Aux channel for 60 seconds allowing the feeder pump to prime. Priming is stopped when quitting the menu or after 60 seconds.

Text:	Priming
Default:	OFF
Entries:	ON; OFF

5.4.5 ACO Injection

Set AcO parameters.

The injection takes place on Friday during the day, the time may vary depending on the filtration cycles:

- In **24/24** mode, injection will be activated at 1 p.m.
- In other modes, the injection will take place between 8 a.m. and 6 p.m. subject to a filtration period long enough to allow the injection.

ACO injection is only possible with XM8 Extension Module and is controlled by AUX 12

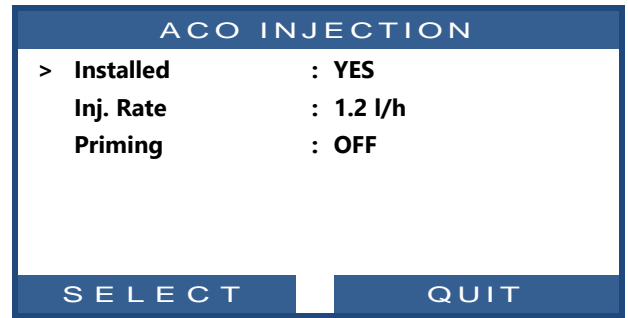

5.4.5.1 Installed

If **INSTALLED: YES**, PoolCOP will control the ACO injection according to parameters settings.

If set to **NO**, this function is deactivated.

Text:	Installed
Default:	NO
Entries:	YES; NO

5.4.5.2 Injection Rate

Set the feeder pump injection rate. Combined with pool volume (**POOL DATA** menu), the injection rate will be used to calculate the remnant injection duration based on **25 ml/m3/week**.

Text:	Inj. Rate
Default:	1.2 l/h (7.5 GPD)
Entries:	0.1 - 9.9 l/h (0.63 - 62.8 GPD)

5.4.5.3 Priming

Ensure the feeder pump is connected to chosen Aux and correctly powered.

Commanding priming **ON** will activate the Aux channel for 60 seconds allowing the feeder pump to prime. Priming is stopped when quitting the menu or after 60 seconds.

Text:	Priming
Default:	OFF
Entries:	ON; OFF

5.4.6 Free Available CL

See the **PoolCOP Chlorine Sensor FAC Installer and User Manual** for information and guidance.

5.5 MAINTENANCE

Specific parameters dedicated to pool maintainers.

MAINTENANCE	
> Service Mode	: NO
Measure pH	: 7.7
Calibrate pH	: 0.1
Value FAC	: 3.2
Calibrate FAC	: 1.2
Calibrate Conduct	: 200uS
Salt Level	: 2.5
Air AntiFrz.	: 5°C
Stop treatmnt	: 12°C
Calib T° (=)	: 28°C
SELECT	QUIT

5.5.1 Service Mode

In service mode, PoolCOP stops all its automatic actions. Every connected device (pump, Auxiliaries, water refill...) is stopped when using this mode. PoolCOP will only respond to manual command. This mode could be used for passive winterization or during maintenance actions.

Text:	Service Mode
Default:	NO
Entries:	YES;
	NO

5.5.2 Measure pH

Perform an extra pH measurement. The filtration pump must be stopped to allow measurement (except in **24/24** mode)

pH READING	
Check TAC >80 ppm	
Last pH reading:	
20:12 15-03-2020	
Press SELECT	
SELECT	QUIT

5.5.3 Calibrate pH

Calibrate pH to a known value.

CALIBRATION	
Check TAC >80 ppm	
Ref : 7.00	
Confirm Ref	
Then press	
SELECT to calibrate	
SELECT	QUIT

Text:	Calibration
Default:	7.0
Entries:	6.5;
	8.5

Carry out a calibration procedure for the pH sensor.



NOTE:
If alkalinity is NOT AT LEAST 80 ppm, pH calibration and measurement will be unreliable. Ensure that alkalinity is correct, and the body of water is adequately mixed, before calibration.



NOTE:
During the calibration process, PoolCOP compares the "offset" of the probe to the signal that would be delivered by a perfect probe. This offset is essentially related to sensor aging. If the offset is too large, calibration is not possible. It is then necessary to check that the reference pH is correct. If this is the case, the probe must be replaced.

5.5.4 Value FAC

Requests an immediate update of FAC value instead of waiting for the next polling (within 30 seconds). This menu is detailed in **PoolCOP Chlorine Sensor FAC Installer and User Manual**. Please refer to this manual for menu details.

5.5.5 Calibrate FAC

Performs a FAC calibration against a DPD1 analysis. This menu is detailed in **PoolCOP Chlorine Sensor FAC Installer and User Manual**. Please refer to this manual for menu details.

5.5.6 Calibrate Conductivity

Calibrate Conductivity or salt level to a known value if PoolCOP Ocean and conductivity sensor are installed.

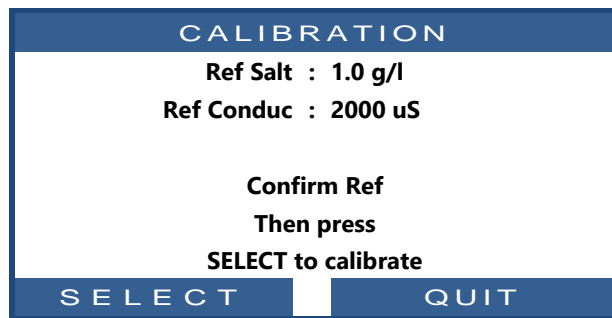

Carry out a calibration procedure for the conductivity sensor. Best result will be achieved by calibration the conductivity in micro-siemens. Alternatively, calibration can be carried out by entering a salt concentration level in g/l

Text:	Calibration
Default:	current value
Entries:	+0 uS --2000uS



NOTE:
Calibration using salt level will be less accurate than calibration with controlled conductivity.

5.5.7 Air Anti-Freeze

When an air sensor is connected, defines the air temperature value to start antifreeze protection. See 4.4.4.7 Antifreeze Protection for further details.

Text:	Air Antifrz
Default:	-5°C (23°F)
Entries:	-9°C - 9°C (15.8°F - 48.2°F)

5.5.8 Stop Water Treatment

When water temperature decreases some disinfection devices (for e.g. salt systems) are prone to more rapid wear. However, algae, viruses and bacteria growth slow down considerably in cold water; reducing the run time of these devices thus serves to extend their lifespan. Choose the temperature value to stop all ORP driven disinfection systems. **Setting the temperature to 0°C (32°F), deactivates protection.**

Text:	Stop Treatment
Default:	12°C (53.6°F)
Entries:	0°C - 18°C (32°F - 64.4°F)

5.5.9 Adjust Water Temperature

Allows you to align PoolCOP temperature indication to third party equipment like a heat pump by adding an offset to the temperature indication. The value between parenthesis is the indication of offset.

- < , offset is negative
- = no offset
- > offset is positive..

Text:	Temp
Default:	0.0°C (32°F)
Entries:	-9.9°C - 9.9°C (14.2°F - 49.8°F)

5.6 CONFIGURATION MENU

PoolCOP configuration menu.

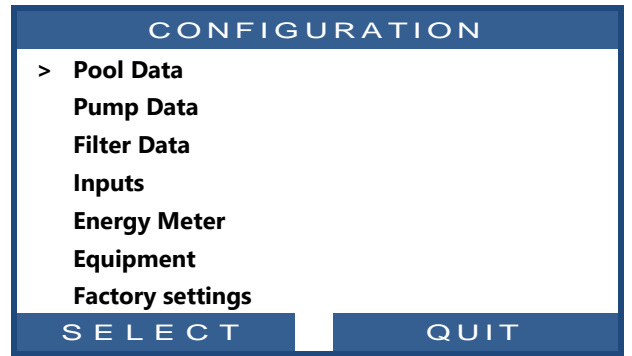

5.6.1 Pool Data

Set pool parameters.

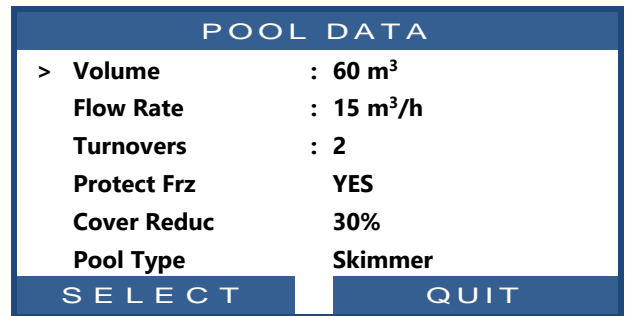

5.6.1.1 Volume

Enter the pool **VOLUME**. This is used for filter duration calculations in all automatic modes.

Volumes less than 10m³ (2640 USG) are considered a spa for filter duration calculations. Hydraulic corrections are not applied.

Text:	Volume
Default:	60 m ³ (15850 USG)
Entries:	1 to 900 m ³ (264 to 237750 USG)

5.6.1.2 Flow Rate

Enter the **FLOW RATE** of the hydraulic circuit with a clean filter. This is used for filter duration calculations in automatic modes:

- Measure the actual hydraulic flow and enter this figure for optimum performance; or
- Use the lowest of the nominal filter rate and the nominal pump rate, less 20% as the entered flow rate.
- When programming for use with a variable speed/flow pump, estimate the average daily flow rate.

Text:	Flow Rate
Default:	15 m ³ /h (66 GPM)
Entries:	1 - 250 m ³ /h (4.4 - 1100 GPM)

5.6.1.3 Turnovers

Set the desired **TURNOVERS** per day. This is used for filter duration calculations in **VOLUME** mode.

Text:	Turnovers
Default:	2
Entries:	1 - 10

5.6.1.4 Freezing Protection

Activate or deactivate freezing protection. When freezing risk is detected, either internally or externally (if installed) filtration is run for at least 30 minutes.

Text:	Protect Frz
Default:	YES
Entries:	YES; NO



CAUTION:
PoolCOP freezing protections can only assist in the protection of equipment. PoolCOP cannot guarantee that damage will be avoided under all circumstances, as this depends on many factors. No responsibility will be accepted for damage caused due to freezing.



NOTE:
When freezing risk is detected and filtration started, the pump **CANNOT** be stopped until the temperature detected is higher than the protection setting, or the Protection Antifreeze is switched OFF in the Pool Data menu.



NOTE:
The freezing risk alerts are always active, even with freezing protection OFF.



NOTE:
Multispeed pumps are started on speed #1 supposedly the lowest speed.

5.6.1.5 Filtration Reduction When Pool Cover is Detected Closed

To be effective, this functionality assumes the connection of Pool Cover, or mobile floor limit switch to a PoolCOP input. (see 5.6.4). Depending on if pool is configured with a single or multi-speed pump, reduction strategy is different:

5.6.1.5.1 Filtration Time Reduction (Single Speed Pump)

Select the reduction percentage you want to apply to the filtration duration (Apply only to **ECO+** mode) when the cover is closed.

Text:	Cover Reduc
Default:	30%
Entries:	0% - 70%

5.6.1.5.2 Pump Speed Reduction (Variable or Multi Speed Pump)

Select the desired pump speed (apply to **every filtration mode**) when the cover is closed. This speed will replace the normal Cycle 1 or Cycle 2 preselected speeds as long as the cover is closed.

If value is **0**, no change will occur when the cover state changes.

Text:	Cover speed
Default:	0
Entries:	0 - 8

5.6.1.6 Pool Type

Selecting the type of pool automatically configures some functions:

- SKIMMER** – the valve reverts to a “safe” **Filter** position whenever filtration is inactive. Water level control is standard.
- OVERFLOW.A** – the valve reverts to a “safe” **Filter** position whenever filtration is inactive. Water level control is adapted to suit an infinity pool.
- OVERFLOW.B** – the valve reverts to a “safe” **Closed** position (to prevent the pool draining into the buffer tank with the pump **OFF**) whenever filtration is inactive. Water level control is adapted to suit an infinity pool.
- SPA** – the valve reverts to a “safe” **Filter** position whenever filtration or other functions are inactive, and there is no volume correction in ECO mode.

Text:	Pool type
Default:	Skimmer
Entries:	Skimmer; OverF.A; OverFB; Spa



NOTE:
Changing the Pool Type affects the way that water level control functions. Be sure to read and fully understand the implications prior to changing this setting.

5.6.2 Pump Data

Set pump parameters.

HAYWARD Range VSTD	
> Low Alert	: 0.5 Bar
Prot. Press	: 0.2 Bar
Circ Prot	: Pressure
Prot. Pump	: YES
Def. Speed	: 1
Cyc 1 speed	: 1
Cyc 2 speed	: 1
Clean speed	: 1
SELECT	QUIT

5.6.2.1 Pump Type

When entering the **PUMP DATA** menu, **LOW ALERT** is preselected. To change the pump from Single Speed Pump to a variable or **variable** speed pump, press the UP arrow and press **SELECT**; now use the arrows to select the pump make and model installed. See the **PoolCOP Variable Speed Pump Guide** for further details including connecting and programming.

Note: **Binary combination** offers the full possibilities of any combination using Pump and Aux1/2/3 relays. This option can be used to control several mono speed pumps.

Text:	
Default:	SINGLE SPEED PUMP
Entries:	SINGLE SPEED PUMP; PENTAIR IntelliComm; PENTAIR SuperFlo VS; HAYWARD Eco Star; HAYWARD Range VSTD; BADU Eco Touch-pro; BADU 90 Eco Motion; ZODIAC FloPro VS; INVERTEK OptiDrive; Binary Combination; Davey ProMaster VSD400; DAB E.SWIM_E.PRO; AQUAGEM iSAVER+; SACI epool enjoy; SCHNEIDER ATV212



NOTE:
SINGLE SPEED PUMP is selected for Pentair IntelliFlo pumps if connected without IntelliComm.

5.6.2.2 Low Alert

Set the pressure at which the Low Pressure Alert is activated. This alert is used primarily to indicate that the skimmer or pump baskets are contaminated, reducing flow and filter pressure. This alert has no effect on the operation of equipment, it is an advisory only.

Setting the pressure limit:

- Start the automatic pool cleaner and set valves.
- Ensure that all debris has been removed from the baskets.
- If using a variable speed pump, set minimum speed or flow programmed.
- Let filtration run for a few minutes to expel any air in the system.
- Note the low pressure reading on the PoolCOP.
- Round off to next lower round number and subtract a 0.20 bar (2.9 PSI) margin.

Text:	Low Alert
Default:	0.50 bar (7.2 PSI)
Entries:	0.1 - 1.90 bar (1.45 - 27.5 PSI)
	(min = PROT. PRESSURE see 5.6.2.3) (max = FILTER PRESSURE see 5.6.3.1)

Example

- Lowest pressure noted = 0.76 bar (11 PSI)
- Round DOWN = 0.70 bar (10 PSI)
- Subtract 0.20 bar (2.9 PSI) = 0.50 bar (7.2 PSI)
- If the alert "WARN: LOW PRESS" displays under normal circumstances, decrease this setting progressively.**

5.6.2.3 Protection Pressure

Set the pressure at which the pump protection will **stop the pump** to avoid damage and activate an alert.

Setting the pressure limit:

- Stop the pump and let the indicated pressure stabilize.
- Note the Pump OFF pressure reading on the PoolCOP:
 - o If the pump is higher than the pool, this should be 0 bar (0 PSI)
 - o If the pump is lower than the pool, there should be a head of pressure.
- Round this figure up and add a margin of 0.20bar (2.9 PSI)
- Set this pressure as the Prot. Pressure.

Text:	Prot. Press.
Default:	0.20 bar (2.9 PSI)
Entries:	0.1 - 1.9 bar (1.45 – 27.5 PSI)
(max = LOW ALERT see 5.6.2.2)	

Example

- Pump OFF pressure = 0.15 bar (2.2 PSI)
- Round UP = 0.20 bar (2.3 PSI)
- Add 0.20 bar (2.9 PSI) = 0.40 bar (5.8 PSI)

5.6.2.4 Activate Pump Protection

PoolCOP protects the pump, by switching OFF the pump and integrated water treatments in the event pressure measured is below the Prot. Pressure for 8 minutes. In the case where pumps have their own protection systems, this protection can be inhibited to prevent protection conflicts.

Switching Prot. Pump OFF disables the pump protection in the event that very low pressure is measured. Alerts are still active, and in the event of the Alert activation other internal functions (pH Control, ORP Control, Remnant injection) will stop.

Text:	Prot. Pump
Default:	YES
Entries:	YES, NO



WARNING:
Switching pump protection to OFF should only be done where the pump has its own protection system. If in any doubt, Pump Protection should be ON.



WARNING:
With Prot. Pump OFF, only integrated water treatment functions are stopped when this protection is activated; equipment connected to Aux relays will not be stopped.

5.6.2.5 Def. Speed (if variable speed pump configured)

This will be the default speed when filtration is set in **24/24 MODE**.
If desired, 2 periods with different speed can be configured in **FILTRATION** Menu.

Text:	Deflt Spd
Default:	1
Entries:	1 - 8

5.6.2.6 Cycle 1 Speed (if variable speed pump configured)

Select the speed linked to Filtration Timer cycle 1.
(Number of speeds depends on pump type).
For overflow pools fitted with a suction valve, this speed is selected when the valve is in bottom position.

Text:	Cycle1 Spd (Bottom spd)
Default:	1
Entries:	1 - 8

5.6.2.7 Cycle 2 Speed (if variable speed pump configured)

Select the speed linked to Filtration Timer cycle 2.
(Number of speeds depends on pump type).
For overflow pools fitted with a suction valve, this speed is selected when the valve is in surface position.

Text:	Cycle2 Spd (Surface Spd)
Default:	1
Entries:	1 - 8

5.6.2.8 Cleaning Speed (if variable speed pump configured)

Select the speed linked to filter cleaning
(Number of speeds depends on pump type)

Text:	Clean Spd
Default:	1
Entries:	1 - 8

5.6.3 Filter Data

FILTER DATA	
Pressure	: 1.00 Bar
Flow	: 0.0 m3/h
On speed	: 1
Frequency	: 0
Time	: 22:30
Waste Valve	: NO
Cleaning	: MANUAL
Backwash	: 80 Sec
Rinse	: 20 Sec
Suction	: None
Clean Via	: Surface
APF Dosing	: NO
Priming	: OFF
SELECT	
QUIT	

Set filter parameters.

5.6.3.1 Pressure

Set the pressure at which filter cleaning is triggered.

If measured pressure exceeds this threshold pressure for more than 5 minutes, an alert to clean the filter will be triggered.

Setting the pressure limit:

- Remove/stop the automatic pool cleaner and reset valves.
- Ensure that all debris has been removed from the baskets.
- If using variable speed pump, set maximum speed or flow programmed.
- Let filtration run for a few minutes to expel any air in the system.
- Note the base pressure reading on the PoolCop.
- Round off to next higher round number and add a 0.10 bar (1.5 PSI) margin.

Text:	Pressure
Default:	1.50 bar (21.7 PSI)
Entries:	0.1 - 1.90 bar (1.45 – 27.5 PSI)
(min = LOW ALERT see 5.6.2.2)	

Example

- Base pressure noted = 0.88 bar (12.8 PSI)
- Round UP = 0.90 bar (13.0 PSI)
- Add 0.10 bar (1.5PSI) = 1.00 bar (14.5 PSI)
- If clean filter alerts occur too frequently, increase this setting incrementally.
- Whenever resetting or adjusting this pressure, ensure that the filter is clean to get an accurate base pressure.
- Generally base pressure decreases over time as the filter media deteriorates.
- A steadily increasing base pressure indicates that the filter media is clogging.

5.6.3.2 Flowrate

Only when a FlowVis flowmeter is configured. Enables filter cleaning at a low flowrate.

Set the low flowrate threshold to trigger filter cleaning.

Flowrate settings differ according to FlowVis flowmeter type.

Text:	Flow
Default:	0.0 m3/h (0 gpm)
Entries:	0.0 m3/h (0 gpm); 409 m3/h (1800 gpm)

5.6.3.3 On speed

Only when a FlowVis flowmeter is configured (see above) and the pump is multispeed type. Flowrates depend on the selected speed, so it is essential to define at which speed the flowrate to trigger filter cleaning must be monitored.

Text:	On speed
Default:	1
Entries:	1-8

5.6.3.4 Periodic

Set the maximum numbers of days between 2 Clean Filter alerts.
If the periodic cleaning is not required, select 0 days.

Text:	Frequency
Default:	0
Entries:	0 - 250 days

5.6.3.5 Cleaning verification Time

When periodic cleaning is activated set a time at which the reminder to clean filter will be sent.
If periodic frequency is set to 0 days, Time is preset to ---.

Text:	Time
Default:	09:00
Entries:	00:00 - 23:59

5.6.3.6 Waste Valve

Select YES if an automatic waste valve is fitted on the waste line. This valve, controlled by Aux5, will be opened by PoolCOP when the "main" valve is on Waste, Backwash or Rinse positions.

Text:	Waste Valve
Default:	NO
Entries:	YES; NO



NOTE:
Waste valve is controlled by Aux5 Relay. If Aux5 relay is already in used for any reason, it will not be possible to select 'Yes' for waste valve. Aux5 must be declared 'Available' first.

5.6.3.7 Cleaning

Select the cleaning mode according to your needs and according to the filtering media possibilities (see below)

Text:	Mode
Default:	Inhibit
Entries:	Inhibit; manual; auto



CAUTION:
Incorrect setting of the cleaning function can result in damage to the filtration equipment.

The following settings are required:

Type of filter	Setting	Functions
Cartridge	INHIBITED Backwash impossible	<input type="checkbox"/> Four valve positions are available (Backwash and Rinse are inhibited). <input type="checkbox"/> If configured, automatic water level reduction sends surplus water to waste.
D.E.	MANUAL Replacement D.E. charge required immediately after cleaning cycle	<input type="checkbox"/> All six valve positions are available. <input type="checkbox"/> Backwash and Rinse durations can be configured. <input type="checkbox"/> The filter is cleaned only via MANUAL CONTROL menu. <input type="checkbox"/> If configured, automatic water level reduction sends surplus water to waste.
Sand or Multimedia	AUTO	<input type="checkbox"/> All six valve positions are available. <input type="checkbox"/> Backwash and Rinse durations can be configured. <input type="checkbox"/> Filter media is auto cleaned as required, and via MANUAL CONTROL menu. <input type="checkbox"/> If configured, automatic water level reduction uses surplus water to clean the filter media.

5.6.3.8 Backwash

Displayed if **CLEANING: AUTO** or **CLEANING: MANUAL**.
Set the desired backwash duration.
Refer to the filter manual for recommended backwash duration.

Text:	Backwash
Default:	60 seconds
Entries:	10 – 600 seconds

5.6.3.9 Rinse

Displayed if **CLEANING: AUTO** or **CLEANING: MANUAL**.
Set the desired rinse duration.
Refer to the filter manual for recommended rinse duration.

Text:	Rinse
Default:	20 seconds
Entries:	10 – 180 seconds

5.6.3.10 Suction valve

A BESGO 3-way valve can be added to pump suction line to get water either from the surface (skimmer or buffer tank) or from the bottom of the pool.

Valve will be controlled by Aux4.

Text:	Suction
Default:	None
Entries:	None; BESGO

NOTE:

The position of the suction valve is governed by a set of rules.

See 5.9 Circulation Modes for settings.

The rules are listed below in decreasing order of priority:

Overflow pools :

1. If the pump is stopped or not primed, from the surface.
2. Otherwise, during filter cleaning, position defined for filter cleaning (see below).
3. Otherwise, if water level is low, from the drain.
4. Otherwise, if a surface cycle is active, from the surface.
5. Otherwise, if the water level is very high, from the surface.
6. Otherwise, if a bottom cycle is active, from the drain.
7. Otherwise, for pools without cover, from the drain.
8. Otherwise, for pools with cover:
 - If cover is open, from the surface.
 - If cover is closed:
 - If ECO mode is not active, from the drain.
 - If ECO mode is active and the air temperature exceeds its setpoint by 1°C, from the surface.

Skimmer pools and spas:

1. During filter cleaning, position set for filter cleaning (see below).
2. After filter cleaning, forced from drain for a period of 15 to 120 minutes. (see 5.4.1.7).
3. Otherwise, if water level is low, from drain.
4. Otherwise, from the surface.



5.6.3.11 Clean via

If a BESGO 3-way suction valve is configured, you can choose whether the water to clean (and rinse) the filter is taken from the surface (skimmer or buffer tank) or directly from the bottom of the pool.

Text:	Clean via
Default:	Surface
Entries:	Surface; Bottom

5.6.3.12 APF (flocculant) Dosing

Flocculant (APF) can be injected continuously when the filtration is on (pump started and water goes through the filter).

To ensure automatic injection, declare "APF dosage=YES".

It will be controlled by the Aux8 output provided the XM8 Extension Module is present.

Text:	APF Dosing
Default:	NO
Entries:	NO; YES

5.6.3.13 Priming

Ensure the feeder pump is connected to Aux8 and correctly powered.

Commanding priming **ON** will activate the Aux channel for 60 seconds allowing the feeder pump to prime. Priming is stopped when quitting the menu or after 60 seconds.

Text:	Priming
Default:	OFF
Entries:	ON; OFF

5.6.4 Inputs

Choose inputs type to set

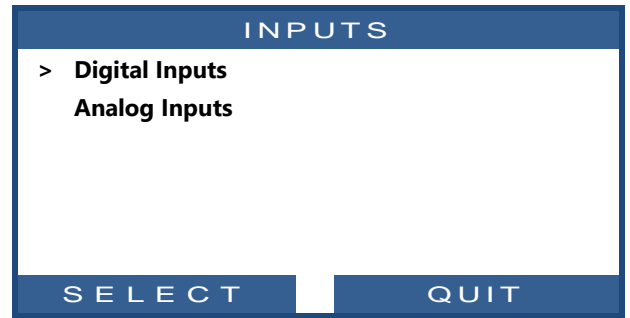

5.6.4.1 Digital Inputs

Set digital inputs identifier and behavior.

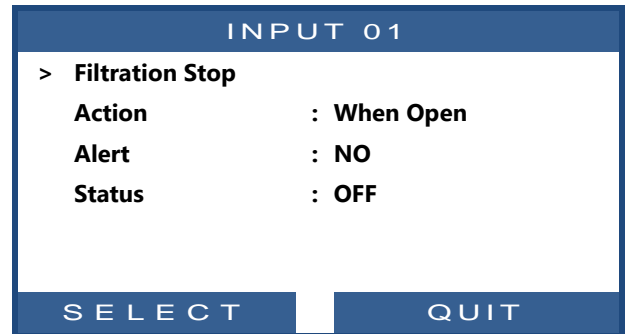

WARNING:

If the equipment is used for pH, ORP or any other treatment or equipment control which does not have its own no flow protection, a flow detection sensor is strongly recommended.

5.6.4.1.1 Input Name

Various inputs can be installed and configured for use with PoolCop.

Text:	None
Default:	Available
Entries:	Available; Thermostat AntiFrz; Disinf Consumables; pH Consumables; Consumables; Pool Cover; Salt System; Filtration Start; Filtration Stop; JetStream; Flow Switch; Flooding; FloodingStop; Low FAC Flow; ACO (Oxidant) consumab; APF (Flocc) Consumables; Overflow; Open Cover; Close Cover; Electrolyser Protection

5.6.4.1.2 Sense of Action

The sensor action configures whether the alert action is taken when the circuit is closed (direct action) or open (reverse action). For example:

- If the thermostat contact closed indicates a freezing risk, choose “**Action when CLOSED**”.
- If the level detection senses that consumables are low by opening the contact in the switch, choose “**Action when OPEN**”.

Text:	Action
Default:	When CLOSED
Entries:	When CLOSED; When OPEN

Configures whether the alert is triggered when the circuit is closed (direct action) or open (reverse action).



NOTE:
When configuring an input as a Flow Switch function, sense of action is preset to “WHEN CLOSED” and cannot be changed.

5.6.4.1.3 Alert

Determines whether an Alert is associated with the sensing on the input or not. If **YES**, when input is detected, an alert will be displayed on screen and send to server (if connected to internet)

Text:	Alert
Default:	NO
Entries:	NO; YES



NOTE:
When configuring an input as a Flow Switch function, Alert is preset to “NO” and cannot be changed.

5.6.4.1.4 Input Role

The inputs can be assigned to various functions, and the setting is used to inform the software functions assigned to each entry. The following predefined functions are available:

Entries	Delay	Role, Note
Available		Default. The input is not active.
Thermostat Antifreeze	5 seconds	The connection of an external antifreeze thermostat assists in protection against damage due to freezing. When detected and if the mode is activated in POOL DATA menu, anti-freeze protection is activated, and filtration is started, and is accompanied by an alert.
Consumables Disinfection	5 seconds	The connection of a consumables low level detector (typically a float switch on a suction wand) triggers an alert when low level is detected. This alert is dedicated to disinfection consumables.
Consumables pH	5 seconds	The connection of a consumables low level detector (typically a float switch on a suction wand) triggers an alert when low level is detected. This alert is dedicated to pH control consumables.
Consumables	5 seconds	If two chemical level sensors are combined, (for example one for disinfection and one for pH control) these two signals can be wired in parallel, so that a single signal can trigger the “Consumable” alert. This is useful when the second input is required for another action, such as Pool Cover position for example.
Pool Cover	2 seconds	To reduce the duration of filtration (if in ECO+ mode) and ionization when the cover is closed. Generates an alarm in the non-closed position. If the pool is equipped with a variable speed pump, PoolCOP switches on the speed n ° 1. When the cover is re-opened during a cycle of operation of the pump, the speed associated with this cycle is restored. If a filtration cycle is running when the cover is closed, this cycle will not be affected by reduction. Only the following cycles will be affected.
Salt System	60 seconds	With a compatible saltwater chlorination system installed and connected, the LOW SALT and/or SHUTDOWN feature will trigger an alert message “Salt System: Intervention Required”.
Filtration Start *	2 seconds	The input can be used to command the filtration to run by means of an external run command, from a switch, button or an external automation. Removing this input command will stop the filtration unless ON in another mode.
Filtration Stop *	2 seconds	The input can be used to stop the filtration using an external control. Warning: This decision overrides any other orders including antifreeze protection. If a filter cleaning is in progress when the request occurs, it will be stopped, but the filter will be rinsed.
JetStream	0 seconds	The input can be used to toggle a JetStream pump. The action will be taken when a JetStream Equipment is declared (see 5.6.6 for further details).
Flow Switch	2 seconds	The input can be used to connect a flow switch. If the flow is not detected, pH injection, disinfectant injection and Auxiliaries declared slaved to pump will be stopped. Normal situation will resume automatically as soon as the flow is detected again. pH injection may resume immediately as well as auxiliaries, but disinfectant will resume with an observation period, so dosing may restart with 10 minutes delay.

Flooding	2 seconds	A water level sensor is connected to detect presence of water in technical room for instance. An alert will be sent in case of detection.
FloodingStop	2 seconds	Same as flooding above, but action is also taken to stop filtration pump, chemicals dosings and also auxiliaries configured "slaved" to pump.
Low FAC Flow	90 seconds	This function monitors the position of the flow indicator in the FAC flow cell. The correct position of the indicator ensures optimum flow for the measurement of Free Available Chlorine (FAC). An alert is issued in the event of position loss.
Consumables ACO	5 seconds	The connection of a consumables low level detector (typically a float switch on a suction wand) triggers an alert when low level is detected. This alert is dedicated to ACO (oxidant) dosing consumables.
Consumables APF	5 seconds	The connection of a consumables low level detector (typically a float switch on a suction wand) triggers an alert when low level is detected. This alert is dedicated to APF (Flocculant) dosing consumables.
Overflow	2 sec	User can press a button to request pool to overflow at any time. If no others functions prevent overflow, then suction valve will be turned to overflow position. Only applies to infinity pool with suction valve.
Open Cover	2 sec	A key or button to request cover to open (if cover is configured). When key/button is released, the cover will stop in its position.
Close Cover	2 sec	A key or button to request cover to close (if cover is configured). When key/button is released, the cover will stop in its position.
Electrolyser Protection	2 sec	When an electrolyser is controlled (ORP disinfectant = Salt or Ocean), or an aux label is set to "Electrolyser" a specific flow switch can be installed to check flow in the electrolysis cell. No flow will stop production with alert.

Note: the delay is used to filter out events of very short duration.

5.6.4.2 Analog Inputs

See FlowVis flowmeter installation guide.

5.6.5 Energy Meter

Energy Meter configuration.

ENERGY METER	
> Type	: None
Modbus ID	: 1
Status	: Absent
P1 (W)	: 0
P2 (W)	: 0
P3 (W)	: 0
SELECT	
QUIT	

5.6.5.1.1 Type

Declare the right type of energy meter.

Text:	Type
Default:	None
Entries:	None Monophase Triphase

5.6.5.1.2 Modbus ID

This is the energy meter identifier on the Modbus network.

Text:	Modbus ID
Default:	1
Entries:	1 -247



NOTE:
Default value is 1 unless otherwise specified by technical support.

5.6.5.1.3 Status

Device status on the Modbus network. This information is read-only:

- Absent: the device is not connected or not detected on the network. Check connection and device type.
- OK: the device is connected and providing measurement data.
- Error: an error has occurred on the network. If this condition persists, please contact support.

Text:	Status
Default:	Absent
Entries:	Absent; Ok; Error

5.6.5.1.4 P1, P2, P3

Instantaneous active power.

Text:	P1, P2, P3
Default:	-
Entries:	Power

5.6.6 Equipment

Allows you to define the Pool Cover, JetStream settings.

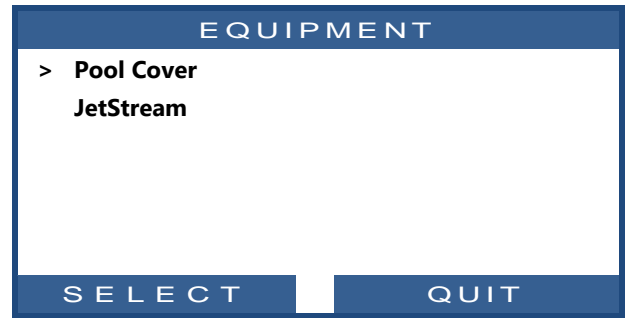

NOTE:
These functionalities are only available if an XM8 is installed and if the required Aux outputs and Inputs are free to used.

5.6.6.1 Pool Cover

Set Pool Cover parameters.

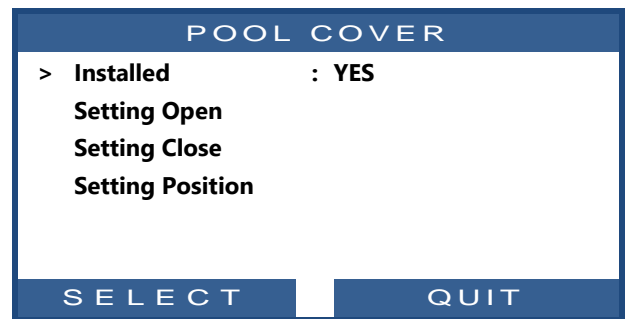

WARNING:
Remote control of a Pool Cover can cause severe injury.
The user **MUST ALWAYS** have the pool in direct view when maneuvering the cover.
The pool must be monitored at all times during the operation of the Pool Cover to ensure that no person is in the pool or enters the pool.
The remote control of the Pool Cover is reserved for maintenance operations carried out by an authorized installer.

5.6.6.1.1 Installed

If **INSTALLED: YES**, PoolCOP will be able to control the Pool Cover opening and closing.
If set to **NO**, the Pool Cover (if any) will be operated manually.

Text:	Installed
Default:	NO
Entries:	YES; NO

5.6.6.1.2 Opening Setting (Aux14 Settings)

When Pool Cover function is installed, Aux14 (Open command) is preconfigured in pulse mode with 2 minutes pulse duration. These settings can be changed from this view. Duration should be long enough to allow full cover operation from closed to open.

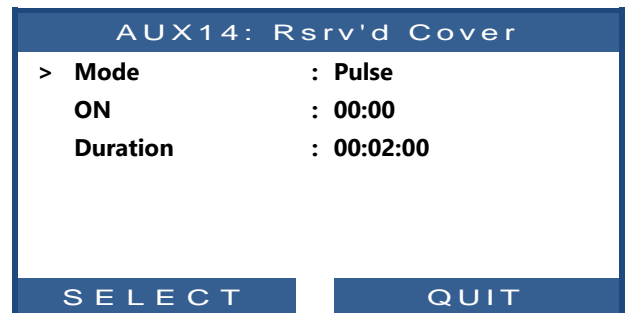

5.6.6.1.3 Close Setting (Aux15 Settings)

When Pool Cover function is installed, Aux15 (close command) is preconfigured in pulse mode with 2 minutes pulse duration. These settings can be changed from this view. Duration should be long enough to allow full cover operation from open to close.

AUX15: Rsrv'd Cover	
> Mode	: Pulse
ON	: 00:00
Duration	: 00:02:00
<div style="display: flex; justify-content: space-between;"> SELECT QUIT </div>	

5.6.6.1.4 Position Setting (IN10 Settings)

When Pool Cover function is installed, IN10 is preconfigured for Pool Cover 'closed' position sensing. The settings can be changed from this view, in particular, one can decide to get an alert (or not) when cover is not detected closed.

INPUT 10	
> Pool Cover	
Action when	: Closed
Alert	: NO
<div style="display: flex; justify-content: space-between;"> SELECT QUIT </div>	

5.6.6.2 JetStream

Set JetStream parameters.

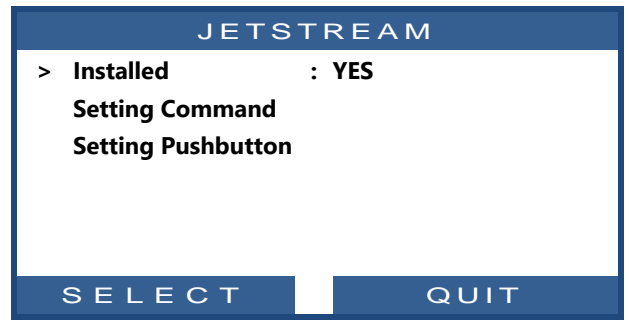

5.6.6.2.1 Installed

If **INSTALLED: YES**, PoolCop will be able to control a JetStream via the push button in the pool or via a direct command.
If set to **NO**, the JetStream (if any) will be operated manually.

Text:	Installed
Default:	NO
Entries:	YES; NO

5.6.6.2.2 Setting Command (Aux13 Settings)

When JetStream is installed, Aux13 (Pump command) is preconfigured in pulse mode with 60 minutes pulse duration. These settings can be changed from this view.

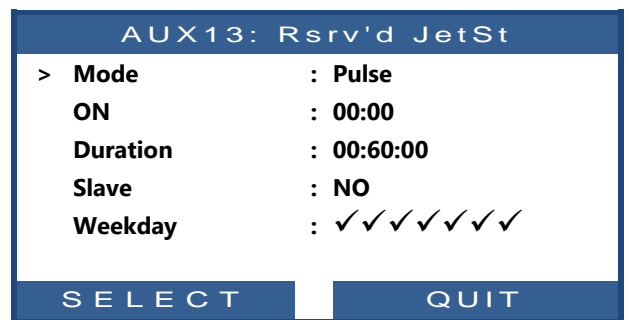

NOTE:
If the pool has a cover and the cover is detected closed by PoolCop, then the JetStream pump is forced OFF for safety reasons. JetStream pump is only allowed to run when the cover is not closed.

5.6.6.2.3 Setting Push Button (IN9 Settings)

When JetStream is installed, IN9 is preconfigured to receive the push button action. The settings can be changed from this view.

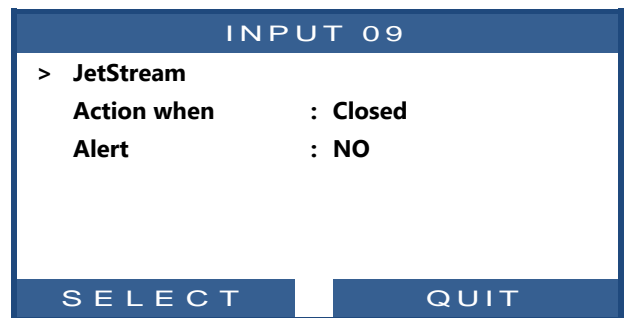

NOTE:
The push button pneumatic signal must be converted into an electrical contact outside PoolCop using a pressure switch. The contact will be then connected on In(9).

5.6.7 Factory Settings

Besides the described settings below, displays the firmware version which may be required for support.

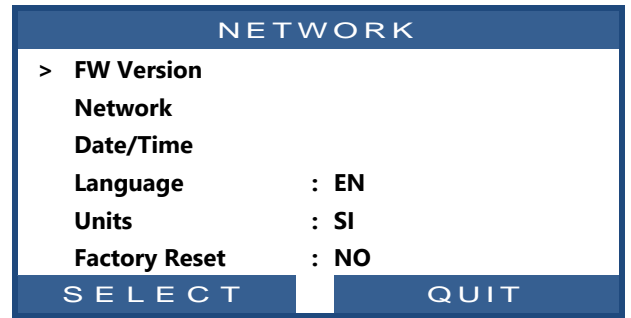

5.6.7.1 FW Version Menu

FW view (with example):

- Firmware version ID (V44.1.0)
- Model and Region ID (STD.EU)
 - o Model GEN => Genesis
 - o Model STD => Standard *
 - o Region EU => Europe
 - o Region US => USA/Canada
- Release date (Sep 22 2020)
- Verification Code (0C1245E)

* Standard is PoolCOP Evolution functionality

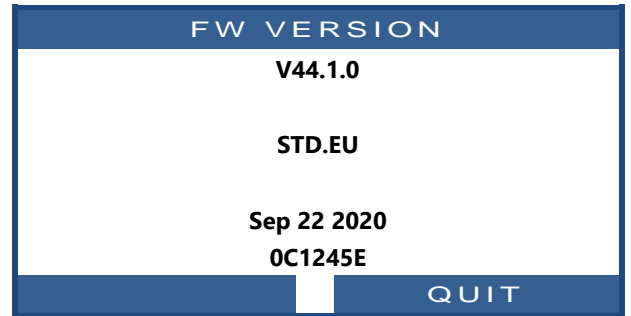

5.6.7.2 Network Menu

- MC:** MAC address, required to link the unit to and account on the PoolCOPilot Server
- IP:** IP address of PoolCOP on the local network
- MSK:** Subnet mask
- DNS:** IP address of the Domain Name Server.
- GTW:** IP address of the gateway (router) on the local network
- SVR:** IP address of PoolCOPilot.com server

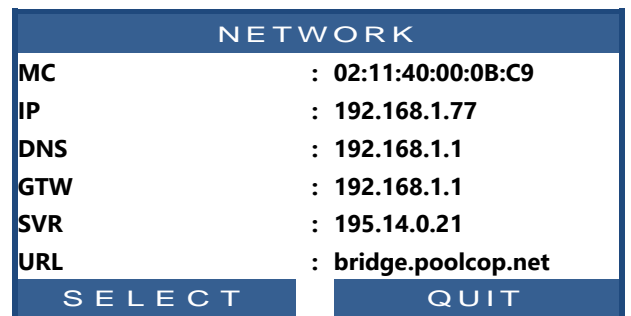

5.6.7.3 Time/Date Menu

Set Time and Date.

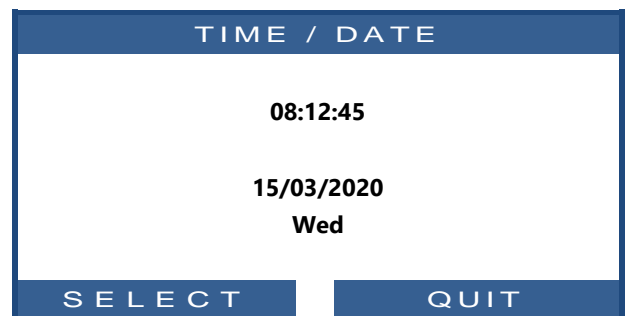

5.6.7.3.1 Setting Time

Set and adjust System Time.

PoolCOP adjusts for daylight savings time if connected to the PoolCOPilot server.

Text:	Time
Entries:	24h

Set and adjust system Date.

PoolCOP adjusts for daylight saving if connected to the PoolCOPilot server.

Text:	Date
Entries:	dd/mm/yyyy

5.6.7.3.2 Setting Date

5.6.7.4 Language Menu

Text:	Language
Default:	EN
Entries:	EN; FR; NL; IT; TK; DE; SP; PT

Select PoolCop language.

5.6.7.5 Units Menu

Text:	Units
Default:	SI *
Entries:	SI; US

Select PoolCop display units.

* Default is SI for EU version of firmware, set to US for US versions.

5.6.7.6 Factory Reset

Text:	Factory Reset
Default:	NO
Entries:	YES; NO

Selecting and confirming resets all defaults and calibrations, requiring reprogramming and pH sensor calibration check.

5.7 POOLCOP CLOUD

PoolCop Cloud display

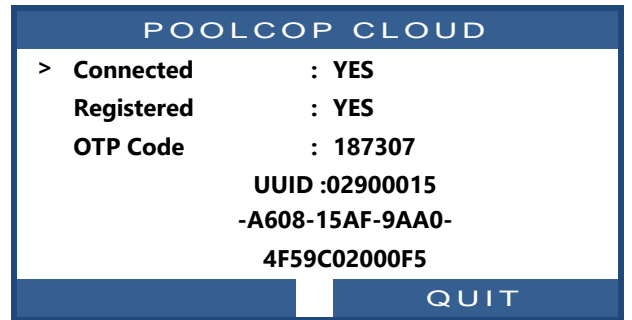

5.7.1 Connected

Display the connection status to PoolCop Cloud.

- YES:** Connection to the cloud is established
- NO:** Connection not established. Please refer to 5.6.7.2 Network Menu.

Text:	Connected
Default:	Read only
Values:	YES; NO

Once PoolCop has been associated with a pool, it will be seen as registered. If not registered, status is **NO**.

Text:	Registered
Default:	Read only
Values:	YES; NO

5.7.2 Registered

5.7.3 OTP Code

One Time Password required to register PoolCop. Will be asked during registration process.

Text:	OTP Code
Default:	Read only
Values:	6 digits number

5.7.4 UUID

Unique hardware identifier.

Text:	Code UUID
Default:	Read only
Values:	32 alphanumeric

5.8 SET PIN CODE

PIN code definition menu.

The PIN code lock prevents access to the menu and maintenance mode. Only the main screen is accessible.

Once the PIN code is entered, the menus become accessible.

The PIN code remains valid for 30 minutes; after this time, the lock is activated again.

PIN CODE	
> Activated	: YES
PIN Code	: 0 0 0 0
Confirm	: 0 0 0 0

SELECT VALIDATE

5.8.1 Activated

Activate the PIN Code

- YES:** PIN Code is activated; screen will be locked.
- NO:** PIN code is not activated.

Text:	Activated
Default:	NO
Values:	YES; NO

Define your own PIN Code.

Text:	PIN Code
Default:	0000
Values:	0000 - 9999

5.8.2 PIN Code

5.8.3 Confirm

Confirm the PIN Code.

Text:	Confirm
Default:	0000
Values:	0000 - 9999

5.9 CIRCULATION MODES

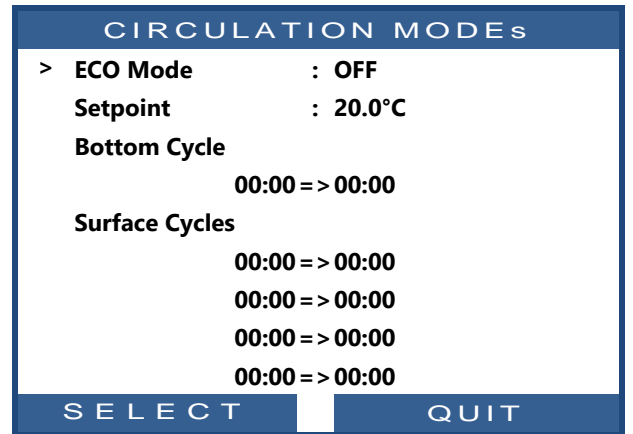

Settings required for ECO mode.

Only applies if a suction valve is configured (See 5.6.3.10 Suction valve)).

5.9.1 ECO Mode

This mode saves heating costs. The optimization of water circulation makes it possible to avoid heat losses and also to maximize the energy contributions under the cover.

This mode only applies for infinity pools with cover configured.

- OFF:** ECO Mode is inactivated.
- ON:** ECO Mode is active: If air temperature is 1°C (fixed value) above Setpoint, water circulation will go through buffer tank.

Text:	ECO Mode
Default:	OFF
Values:	OFF; ON

Applies when **ECO Mode = ON**

This is the air temperature used to trigger the circulation mode switchover (Buffer tank or bottom drain).

Text:	Setpoint
Default:	20°C (68°F)
Values:	0°C - 50°C (32°F - 122°F)

5.9.2 Setpoint

5.9.3 Bottom cycle

The user can decide to force circulation through the bottom drain during a period of the day. Can be useful, for example, to reduce runoff noise at night.

If the conditions are met (no other circulation constraints) then flow will be established through the bottom drain during the defined time slot.

Text:	Bottom Cycle
Default:	ON=00 :00 OFF=00 :00
Values:	00 :00 ; 23 :59;

5.9.4 Surface cycles

The user can decide to force circulation through the buffer tank (ie from the surface) during up to four periods per day.

If the conditions are met (no other circulation constraints) then flow will be established through the buffer tank during the defined time slots.

Text:	Surface Cycles
Default:	ON=00 :00 OFF=00 :00
Values:	00 :00 ; 23 :59;

Section 6 INTERNET CONNECTION

6.1	Introduction	125
6.2	PoolCop Connection to the Web	126
6.2.1	How to get Internet to PoolCop	126
6.2.2	Check the Network Connection	126
6.3	Server Connection and Pool Setup	126
6.3.1	Creating a User Account	127
6.3.2	Adding your first Pool and PoolCopilot Module Automatically	128
6.3.3	Adding a Pool and PoolCopilot Module "Manually"	128
6.3.4	Your Preferences	128
6.3.5	Access Pool or Pools	129
6.3.6	User Interface Options	130
6.4	PoolCopilot Functions	130
6.5	Troubleshooting	130
6.5.1	Error Messages	130
6.5.2	PoolCop will not connect to the server	130
6.5.3	No data displayed	130
6.5.4	No graphs displayed in "History"	130

6.1 INTRODUCTION

The swimming pool can now be accessed 24 hours a day, 365 days a year on a computer, tablet or Smartphone. Pool control can be granted to pool installers, a family member or a neighbor. Each user can choose whether to receive alerts and notifications by email.

6.2 POOLCOP CONNECTION TO THE WEB

6.2.1 How to get Internet to PoolCOP

The CCU is equipped with an RJ45 waterproof compression gland connector.

Bringing the network to the CCU:

- Best is to have an Ethernet cable (mini Cat4) connecting the router to the CCU by RJ45.
- If not possible, Powerline adaptors will allow to carry the Ethernet signal through the 220V power line from the router to the CCU (one Powerline Adaptor at the router and the other adjacent to the CCU):

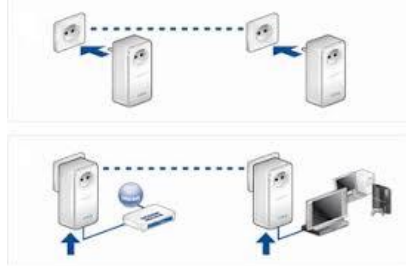

Figure 81 - Power Line Adaptors

- Wi-Fi is a convenient solution to bring the signal to the CCU but may require repeaters along the way to keep the signal strength. This also may require you get access to the WEP or other key code.
- On the CCU side, Insert the RJ45 cable through the cable compression gland supplied as shown in the picture below.



Figure 82 - RJ45 Connector for Ethernet

- Check that access to internet is available at the cable end. You may need a laptop to check this.
- Connect the end of the RJ45 cable to the network so as to establish a connection via the internet box.
- Start PoolCOP (if it was stopped).

6.2.2 Check the Network Connection

- On PoolCOP screen, go to Menu/Configuration/Factory Settings/network and note the MAC address as shown below:

- MC:** MAC address, required to link the unit to and account on the PoolCopilot Server
- IP:** IP address of PoolCOP on the local network
- MSK:** Subnet mask
- DNS:** IP address of the Domain Name Server.
- GTW:** IP address of the gateway (router) on the local network
- SVR:** IP address of PoolCopilot.com server

NETWORK	
MC	: 02:11:40:00:0B:C9
IP	: 192.168.1.77
DNS	: 192.168.1.1
GTW	: 192.168.1.1
SVR	: 195.14.0.21
URL	: bridge.poolcop.net
SELECT	QUIT

6.3 SERVER CONNECTION AND POOL SETUP

This operation requires the use of a computer with an internet browser of your choice. It can be done from any location, though it is preferable to remain in close proximity to the PoolCOP should any communication issues arise.

6.3.1 Creating a User Account

- Connect to the site www.poolcopilot.com.
- On the home page, select **"Create New Account"**.

- Select the type of profile required:
 - **"Personal Account"** will allow you to manage only your own pool as a final customer.
 - **"Pro Account"** will allow you to manage your clients' pools.

- Complete all the information required in the form, in particular:
 - Supply a valid email address; this will be used to identify the client and to route email alerts.
 - Tick the boxes to agree to terms of use, and optionally **"I agree to received data from PoolCOP"** to receive newsletters.
 - Click on **"Submit"** to register and create your new account.

6.3.2 Adding your first Pool and PoolCopilot Module Automatically

- ❑ The setup wizard will now take you to a page to add the MAC address of the PoolCopilot module and create your new pool.
- ❑ Add your 12 number MAC address.
- ❑ Choose a **Pseudo**
- ❑ Click on **submit**.

YOU WILL BE REDIRECTED TO THE CONTROL PANEL VIEW OF YOUR NEW POOL.

Welcome to PoolCopilot! Your account has been created and you are now logged on. In order to use our Web App, you must have the MAC Address of the PoolCOP connected to the Internet to complete the following form.

Connect a PoolCOP to a Pool

6.3.3 Adding a Pool and PoolCopilot Module "Manually"

- ❑ Connect and logon to the site using the email address and password used to create the account.
- ❑ On the Home Page, select "**My Account**" at the top right of the page.
- ❑ Now select "My PoolCops", "connect a PoolCOP"
- ❑ Complete the form:
 - The Mac Address is the unique identification of the new PoolCOP. This code is written on the sticker located on the PoolCopilot Web RJ45 module inside the ABS Box.
 - The nickname allows easy identification of the PoolCOP.
 - If connecting to a new Pool, select "**Add a pool manually**" and complete Pool data.
 - If connecting to an existing pool, select the pool from the dropdown list.
- ❑ Click on "**Submit**".

Connect a PoolCOP to a Pool

6.3.4 Your Preferences

To set preferences such as Language, Units and Formats, select "**My Preferences**":

6.3.5 Access Pool or Pools

In the case where you are managing one swimming pool, you will be automatically directed to the Control Panel. after logging on.

The connection status between PoolCOP and the server can be viewed on the top left. This allows you to ascertain that data is up to date and valid.

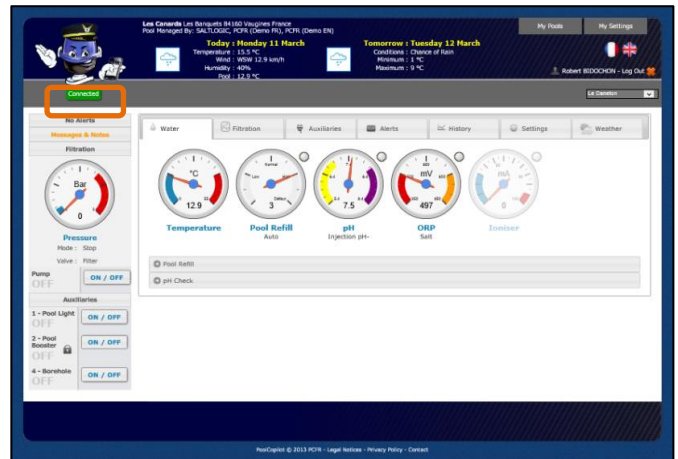

Managing multiple pools you will be directed to the "My Pools" display after logging on; from here you can select the pool and PoolCOP required.

Quickly access a specific pool from the list of pools in your portfolio by selecting a pool by nickname from the drop-down list.

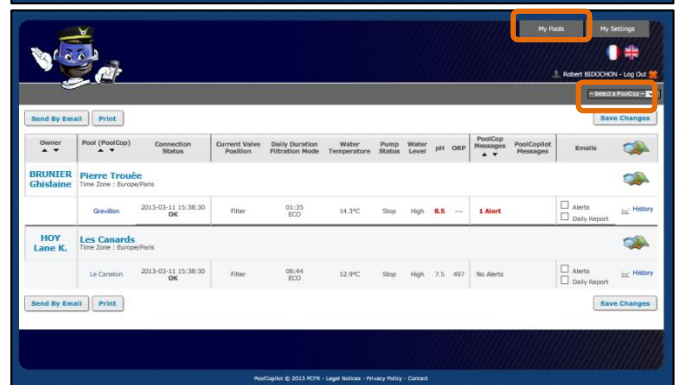

If you wish to give access to the pool to somebody else, go to "Configuration/Pool Managers" and type in the email address provided by the manager.

The pool manager must have or must create an account on www.PoolCopilot.com using the same email address to access the pool.

You can remove this access at any time simply by ticking the corresponding box. Your manager will then be notified he is no longer allowed to access the pool.

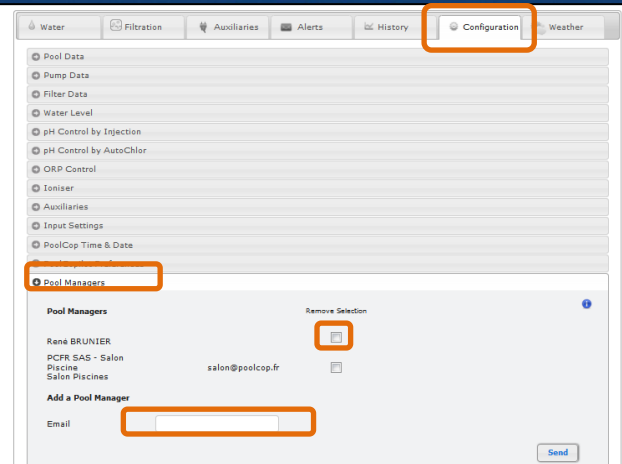

6.3.6 User Interface Options

There are two user interface options, allowing different levels of control of the pool. Change between interfaces by clicking on the button (unless a pool manager has locked the user interface level).

6.3.6.1 EASY

The EASY interface allows basic control and visualization of pool data, as well as personal configuration.

6.3.6.2 EXPERT

The EXPERT interface allows full control of all functions and configuration.



6.4 POOLCOPILOT FUNCTIONS

All PoolCop functions are possible from PoolCopilot. Additional functions are constantly made available as PoolCopilot evolves. These functions are made available via the web interface for all users. The list includes:

- Unlimited email alerts and notifications
- Geo-localization of the pool
- Backup and restoration of configurations
- History of all pool telemetry
- Etc.

Premium Functions add an extra level of functionality, and additional savings:

- Pool and other lighting linked to sunrise and sunset times.
- Delayed refill, to benefit from forecast rain.
- Etc.

6.5 TROUBLESHOOTING

6.5.1 Error Messages

"The MAC address is already in use": check the MAC address

"No PoolCop associated with the following address...": check the MAC address

"The MAC Address field is not a proper MAC address": check the MAC address

6.5.2 PoolCop will not connect to the server

- Check for proper connection in CCU.
- Check for proper connection to the internet box.
- Disconnect the RJ45 cable from the CCU, plug this cable on a laptop (turn Wi-Fi OFF on the laptop), and check that Internet access is available.
- If access is not available, check with router provider / IT service.
- Check IP address on Network menu. If IP is 0.0.0.0, no IP address has been affected to PoolCop, check if the DHCP mechanism is enable on the router and if there is no restriction to access Internet (restrictions on MAC addresses for example)
- Check SVR address on Network menu. If SVR is ---.---.---.---, the PoolCopilot server address was not resolved. Check if the DNS IP address is correct and enable on the router.

6.5.3 No data displayed

- Check that the connection button is green, showing that you are properly connected.

6.5.4 No graphs displayed in "History"

- Check your browser version is up to date.
- Check Flash Player is up to date, if required.

Section 7 SPARE PARTS AND DIAGRAMS

7.1 UF1100-D2 CONTROL CONNECTION UNIT CCU

No	REF	PART	Qty
10	CF1141-F	Enclosure CCU Bocube B273612	1
20	CF1150	Kit PCB Power Supply PCB103	1
30	CO2202	Battery 12V SLA	1
40	CF1100.04	Battery Cable	1
50	CF1140.01	Battery Housing	1
60	CF1140.12	Foam Cushioning	1
80	CF1140.02	Panel Mount Socket RJ45 IP68	1
90	CF1140.04	Cap RJ45 IP68	1
100	CF1114	Switch CCU	1
110	CF1140.21	Face Plate Sticker CCU EVO	1
120	SN004	Decal Serial Number CCU	1

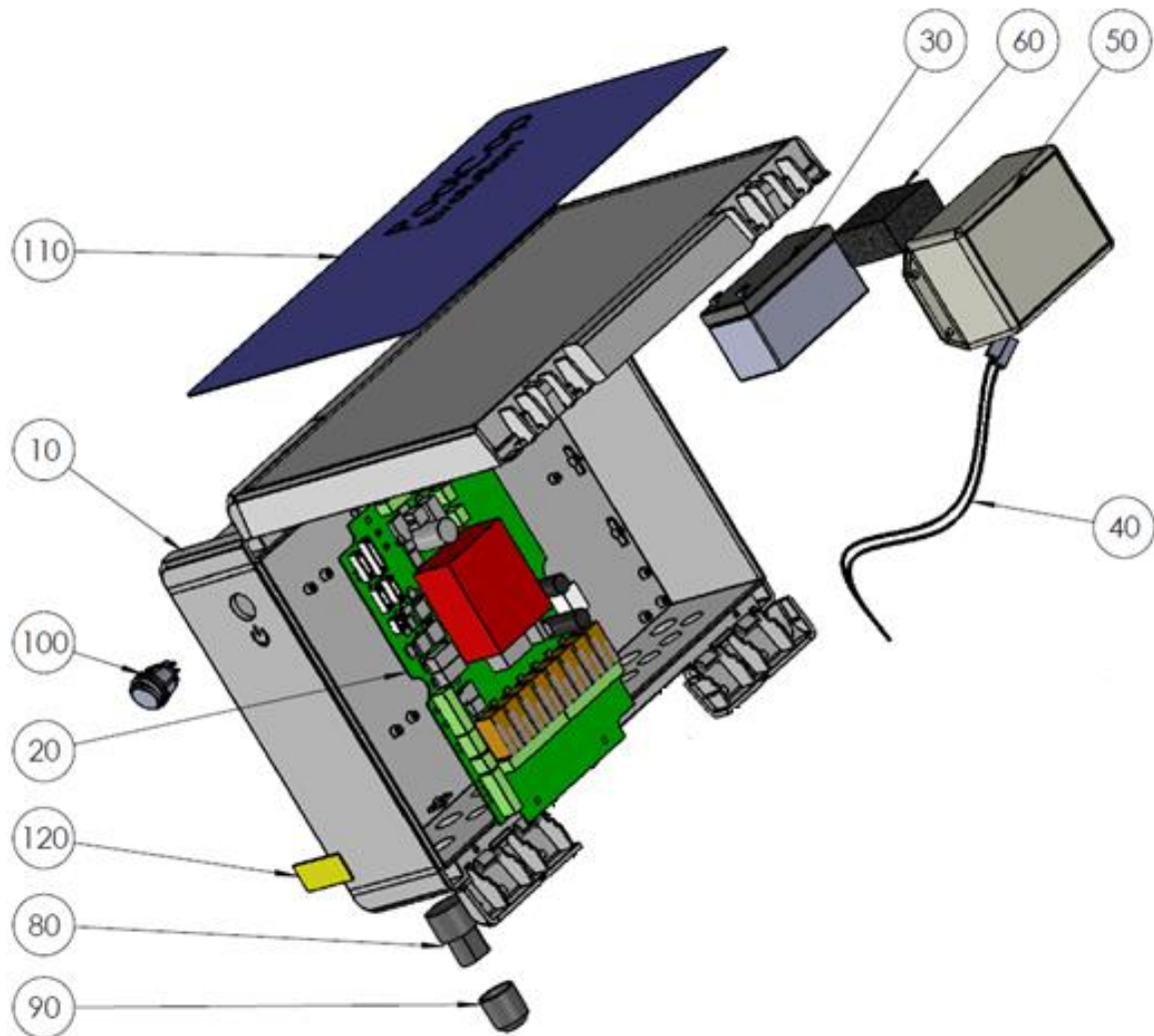

7.2 CF1220-D2 KIT VDU UPPER PART EVO

No	REF	PART	Qty
10	CF1221-D2	VDU Cover with Keypad EVO	1
11	CF1221.01-C	Cover VDU Crystal	1
12	CF1221.15	Spindle female Black	2
13	CF1221.16	Spindle male Black	2
14	CF1221.03	Transparent Window	1
15	JT0005	O-Ring VDU Cover	1
16	CF1221.02-C	Lid VDU Crystal	1
17	CF1221.25	Keypad EVO-D3	1
18	CF1221-17	Fastening Clip VDU Black	2
20	CF1220.01	PCB Micro with LCD Screen	1
30	CF1220.06-C	PCB Micro Int. Cover Drilled	1
40	CF1220.04	Cover Plug PCB Micro	1
50	TFB-M35X10	Screw Head d3.5x10mm	1
60	CF1220.23	Connection Cable UL	1

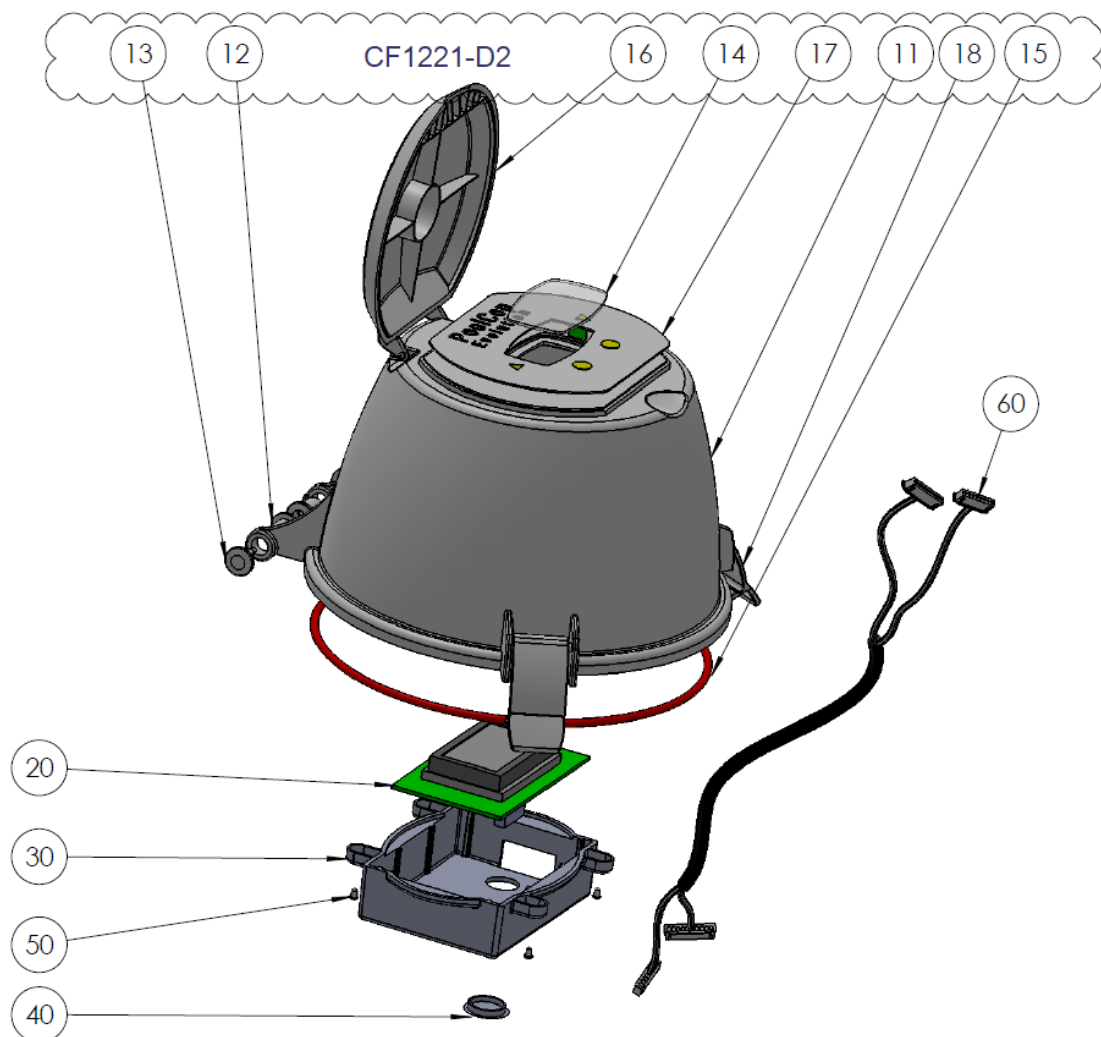

7.3 UF1210-D2 KIT VDU LOWER PART VERSION UF

No	REF	PART	Qté
10	CF1210.27	Base VDU - tie-in closed	1
20	CF1210.03	Motor Unit	1
30	CF1215	Kit PCB Pickup	1
40	CF1218	Kit Connection SE Data	1
50	CF1210.19	Kit Water Temperature Sensor	1
60	CF1224	Kit Sensor Pressure 0.2m Cable	1
70	CF1210.07	Plug VDU M17	2
80	JT0004	O-Ring VDU Plug	2
90	CF1210.02	Electronics Cover	1
100	CF1212.02	pH+ORP Sensor Housing	1
110	SO490x	Kit Sensor SE pH+ORP (not part of the kit)	1
120	JT0006	O-Ring Housing/Plug or shaft	1
130	CF1212.01	Plug Sensor Housing pH+ORP	1
140	JT0001	O-Ring VDU Base	1
150	CF1210.29	DU Datalink Cable UL	1

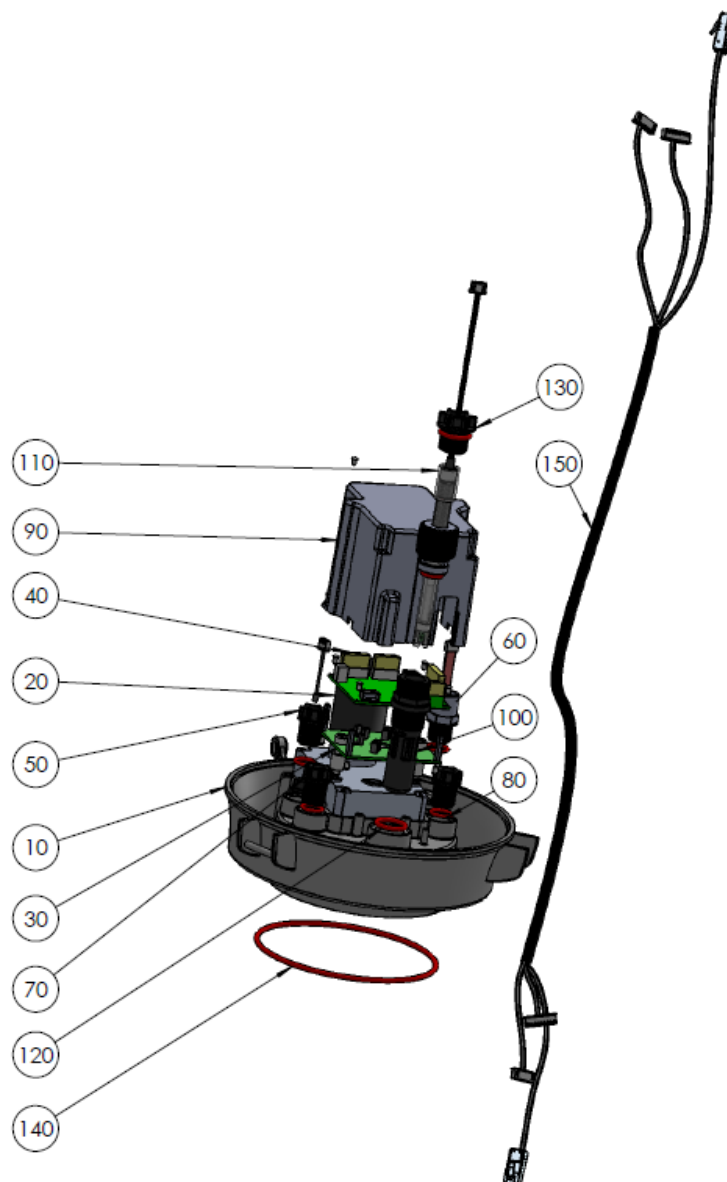

7.4 CF1500 KIT VALVE 1.5"

No	REF	PART	Qté
10	BO1215.03	Valve Spring 1.5"	1
20	CHC-M6X70	Screw CHC M6x70mm	2
30	CHC-M6X35	Screw CHC M6x35mm	4
40	ETH-M6	Nut M6	6
50	W-6x14	Washer M6	6
60	PC1207	Kit Diffuser 1.5"	1
61	BO1215.21	Diffuser 1.5" Gasket NBR	1
62	BO1200.10	Cotter Pin 1.6mm	1
63	JT0001	O-Ring VDU Base	1
64	W-32X43N	Washer ID32mm Th 0.8mm Nylon	2
65	CF1210.16	Positioning Disk Black	1
66	JT0006	O-Ring Housing/Plug or shaft	2
70	BO1215	Kit Valve Housing 1.5"	1
71	BO1215.04	Valve Housing 1.5"	1
72	BO1200.06	Sight Glass	1
73	JT0013	Gasket Sight Glass	1
74	BO1200.04	Drain Plug	1
75	JT0012	O-Ring drain Plug	1

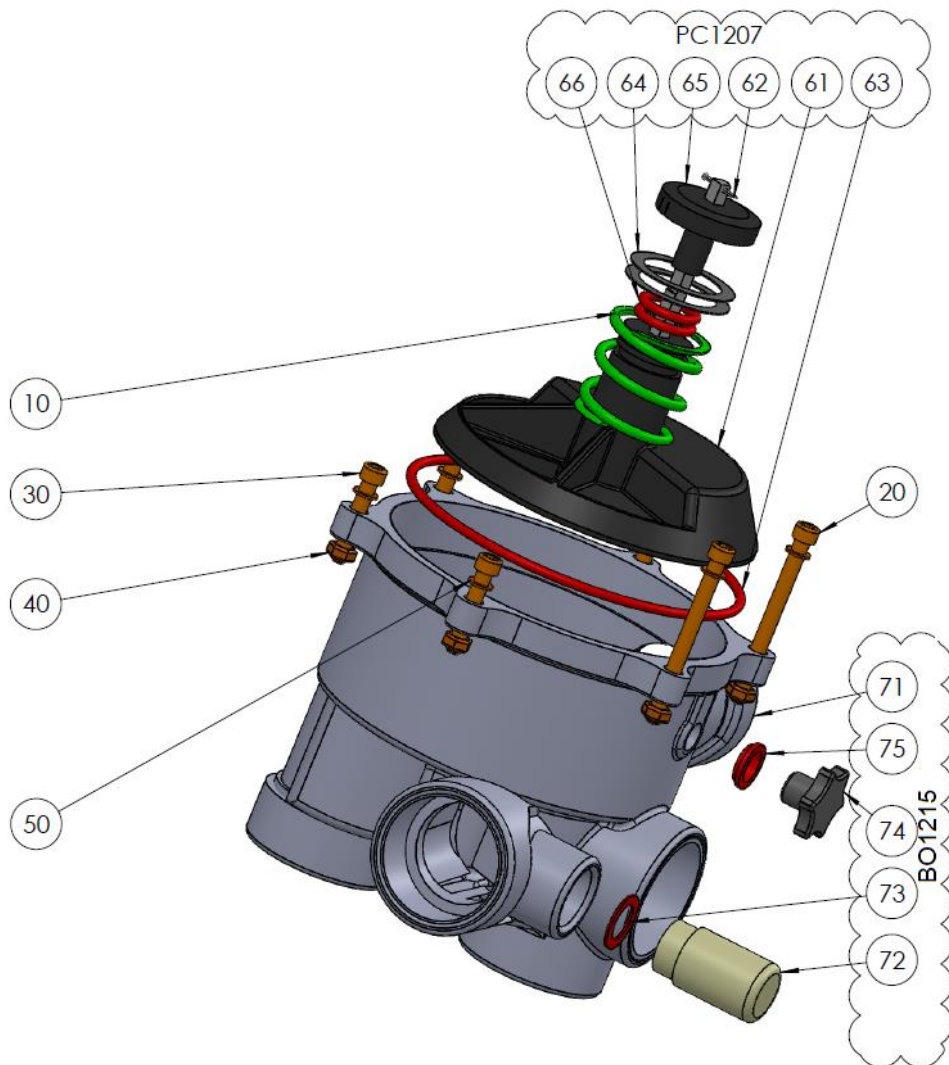

7.5 CF2000 KIT VALVE 2.0"

No	REF	PART	Qté
10	BO1220.03	Valve Spring 2.0"	1
20	CF2000.01	Adapter 2.0"	1
30	CHC-M6X30	Screw CHC M6x30mm	10
40	CHC-M6X60	Screw CHC M6x60mm	2
50	CHC-M6X25	Screw CHC M6x25mm	4
60	ETH-M6	Nut M6	10
70	W-6x14	Washer M6	6
80	PC1208	Kit Diffuser 2.0"	1
81	BO1220.21	Diffuser 2.0" Gasket E40	1
82	BO1200.10	Cotter Pin 1.6mm	1
83	JT0003	O-Ring VDU Base	1
84	W-32X43N	Washer ID32mm Th 0.8mm Nylon	2
85	JT0006	Positioning Disk Black	2
86	CF1210.16	O-Ring Housing/Plug or shaft	1
90	BO1220	Kit Valve Housing 2.0"	1
91	BO1220.04	Valve Housing 2.0"	1
92	BO1200.06	Sight Glass	1
93	JT0013	Gasket Sight Glass	1
94	BO1200.04	Drain Plug	1
95	JT0012	O-Ring drain Plug	1

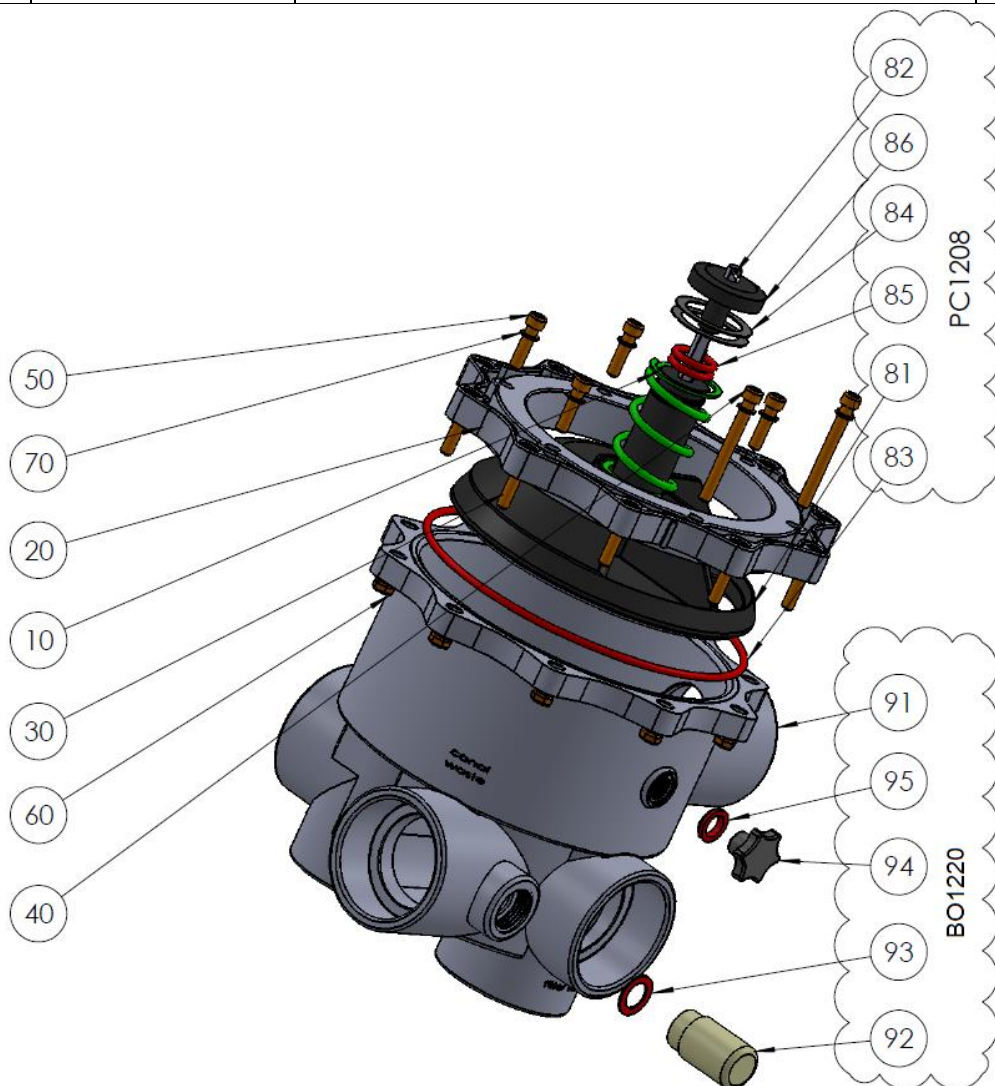

7.6 SO490x PH+ORP SE SENSOR KIT

- SO4902: Sensor SE pH+ORP Platinum
- SO4903: Sensor SE pH+ORP Gold

No	REF	PART	Qty
10	SO490x	Sensor SE pH+ORP	1
20	CF1213.04	Nut for pH+ORP Sensor	1
30	CF1213.02	Grip Washer for pH+ORP Sensor	1
40	CF1213.03	Double Compressor for pH+ORP Sensor	1
50	JT0002	O-Ring pH+ORP Sensor	1

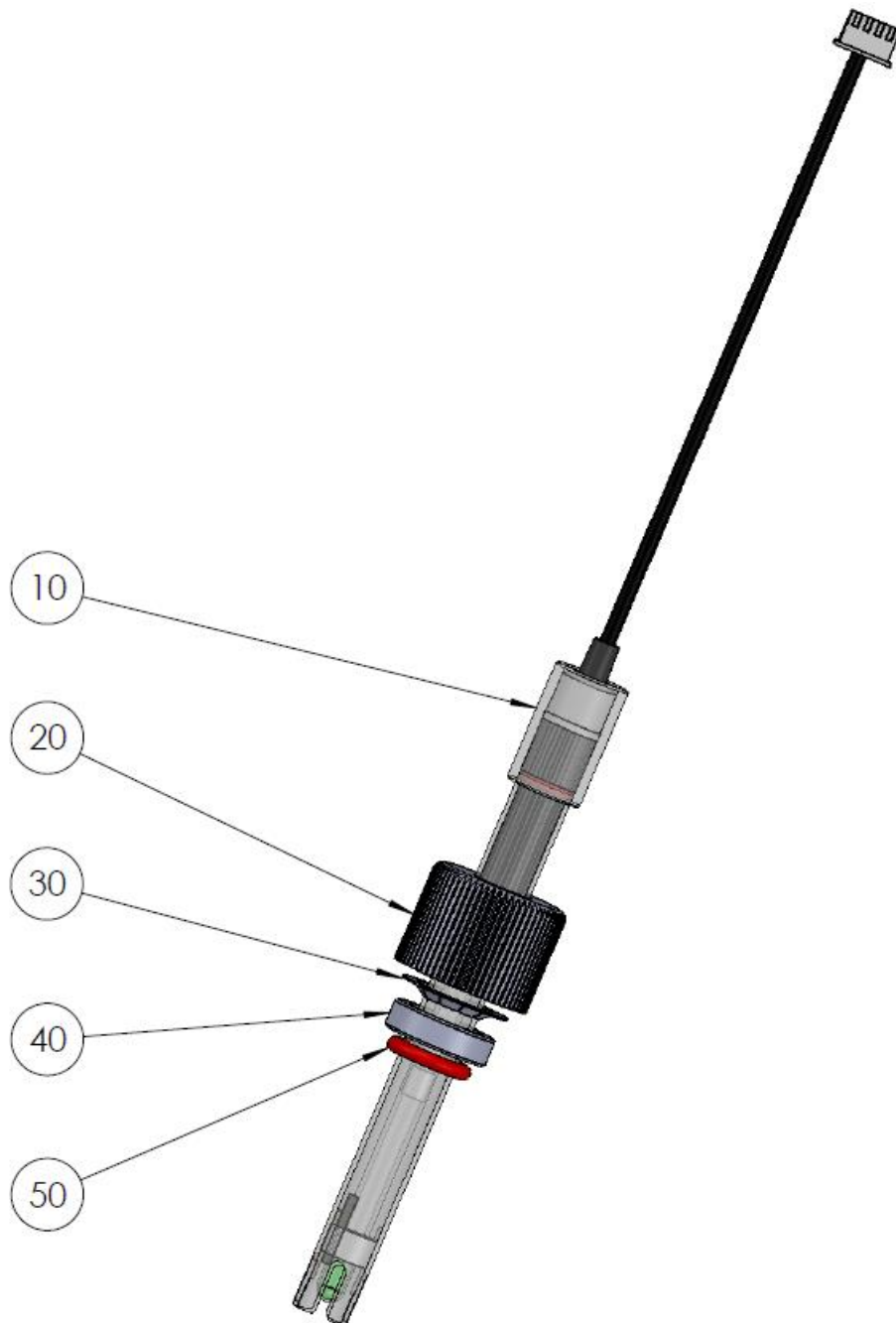

7.7 DECAL AND MARKINGS LOCATION DIAGRAMS

7.7.1 Decals and marking CCU

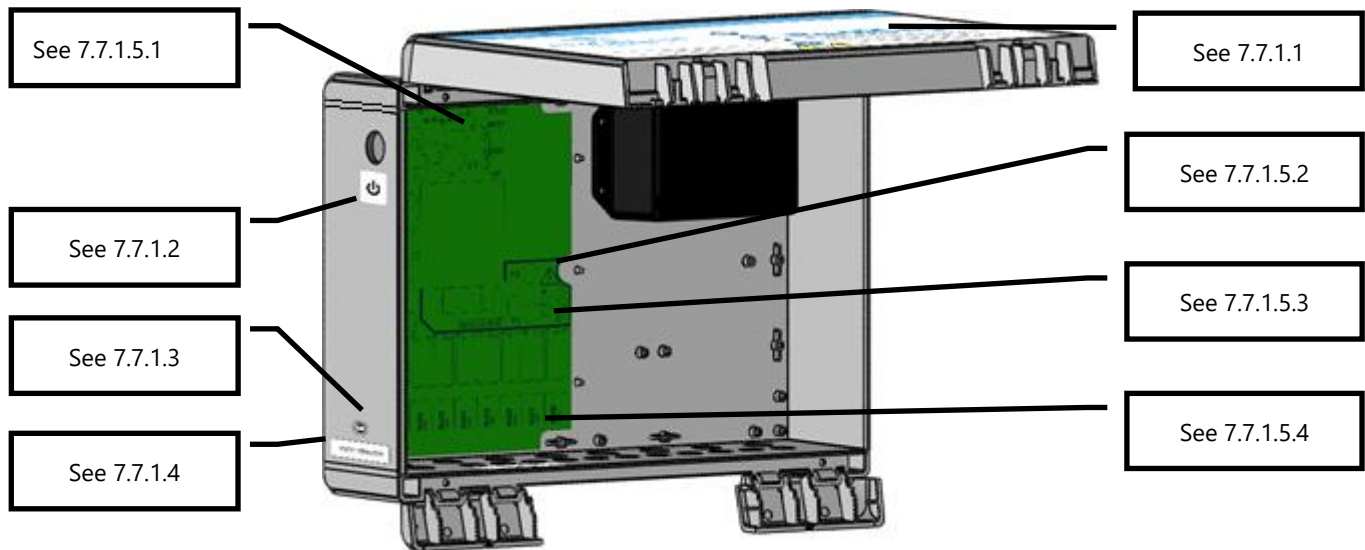

Figure 83 - CCU Decals and Markings

7.7.1.1 CCU Faceplate Decal

Affixed externally on the cover, and includes the following information:

1. Equipment name and model number.
2. Manufacturer's name and contact information (address, website, supplier).
3. Electrical requirements; volts, amps, Hertz, maximum external load rated in volts and amps, and Standby Mode consumption.
4. Replacement sensor model numbers.
5. Replacement fuse specifications.
6. Caution statements and icons, IP rating, CE and WEEE logos.

7.7.1.2 Standby Decal

Affixed externally on the left side of the CCU, below the switch button: standby icon.

7.7.1.3 Date of Manufacture Decal

Affixed externally on the left side at the bottom centered above the CCU Serial Number Decal: product date of manufacture.

7.7.1.4 Serial Number Decal

Affixed externally on the left side at the bottom, centered on the enclosure: product serial number.

7.7.1.5 Marked on the PCB Power Supply

7.7.1.5.1 Fuse Rating Marking

Adjacent to the F3 battery fuse: BATT, 12VDC, 5x20mm cart. 2A Fast Blow, etc.

7.7.1.5.2 Supply and High Voltage Marking

Adjacent to the power cord connector: 115V 230V, L E N, triangular high voltage warning icon, etc.

7.7.1.5.3 Power Fuse Rating Marking

Adjacent to the F1 and F2 power supply fuses: 5x20mm cartridges 160mA Slow Blow (230Vac) 315mA Slow Blow (115Vac)

7.7.1.5.4 Relay Rating Marking

Adjacent to each output relay Max 6A.

7.7.2 Decals and Marking VDU



Figure 84 – VDU Decals and Markings

7.7.2.1 Serial Number Decal

Affixed inside the base on the right side just below the lip of the base: Serial Number.



NOTE:

**The product serial number is the CCU's serial number.
The VDU serial number is for maintenance reference only.**

Section 8 TECHNICAL SPECIFICATIONS

8.1	CE conformity	140
8.2	UKCA conformity	140
8.3	UL/FCC conformity.....	141
8.4	PoolCop Evolution.....	142
8.5	Air Temperature Sensor	143
8.6	pH+ORP Sensors.....	143
8.7	Free Available Chlorine Sensor	143
8.8	Backup Waste Valve.....	143
8.9	Flow Switch.....	144
8.10	Water Level Control	144
8.11	XM8 Extension Module	144

8.1 CE CONFORMITY

The manufacturer declares that the equipment named above has been designed to comply with the relevant sections of the below referenced specifications. The unit complies with all applicable essential requirements of the Directives.

Manufacturer: PCFR SAS, La Remise, 130 boulevard du Nord, 84160 Cucuron (FRANCE)

Equipment: PoolCOP

Model name: PoolCOP Genesis

Directives	Titles	Harmonized Standards
2014/35/EU	Low Voltage Directive	EN 61010-1:2010+A1:2019 EN IEC 62368-1:2020+A11:2020 EN 60730-1:2016+A1:2019+A2:2022
2014/30/EU	EMC Directive	EN 55032:2015/A11:2020 IEC 61000-3-2:2019 IEC 61000-3-3:2013/A1:2019 IEC 61000-4-2:2008 (EN 55035:2017/A11:2020) IEC 61000-4-3:2006+A1:2007+A2:2010 (EN 55035:2017/A11:2020) IEC 61000-4-4:2012 (EN 55035:2017/A11:2020) IEC 61000-4-5:2014 (EN 55035:2017/A11:2020) IEC 61000-4-6:2008 (EN 55035:2017/A11:2020) IEC 61000-4-8:2010 (EN 55035:2017/A11:2020) IEC 61000-4-11:2004 (EN 55035:2017/A11:2020)
2011/65/EU 2015/863/EU 2018/739/EU	Hazardous Substances (RoHS)	EN IEC 63000:2018

8.2 UKCA CONFORMITY

The manufacturer declares that the equipment named above has been designed to comply with the relevant sections of the below referenced specifications. The unit complies with all applicable essential requirements of the Directives.

Manufacturer: PCFR SAS, La Remise, 130 boulevard du Nord, 84160 Cucuron (FRANCE)

Equipment: PoolCOP

Model name: PoolCOP Genesis

Legislation	Title	Harmonized Standards
UK SI 2016 1101	Electrical Equipment (Safety) Regulations 2016	BS EN 61010-1:2010+A1:2019 BS EN 62368-1:2020+A11:2020 BS EN 60730-1:2016+A1:2019+A2:2022
UK SI 2016 1091	Electromagnetic Compatibility Regulations 2016	BS EN 55032:2015/A11:2020 BS EN 61000-3-2:2014 BS EN 61000-3-3:2013 BS EN 55035:2017/A11:2020 BS EN 55035:2017/A11:2020 BS EN 55035:2017/A11:2020 BS EN 55035:2017/A11:2020 BS EN 55035:2017/A11:2020 BS EN 55035:2017/A11:2020 BS EN 55035:2017/A11:2020
UK SI 2012 3032	Restriction of the Uses of Certain Hazardous Substances 2012	BS EN IEC 63000:2018

8.3 UL/FCC CONFORMITY

The manufacturer declares that the equipment named above has been designed to comply with the relevant sections of the below referenced specifications. The unit complies with all applicable essential requirements of the Directives.

Manufacturer: PCFR SAS, La Remise, 130 boulevard du Nord, 84160 Cucuron (FRANCE)

Equipment: PoolCop

Model name: PoolCop Genesis

Norms	Titles	Sections
FCC part 15B	Conducted emissions : AC: 150kHz – 30MHz Radiated emissions: 30 MHz – 1 GHz	FCC §15.107 FCC §15.109
UL1081	Swimming pool pumps, filters and chlorinators	
UL1563	Safety Electric Spas, Equipment Assemblies, and Associated Equipment	

This device complies with part 15 of the FCC Rules. Operation is subject to the following two conditions:

(1) This device may not cause harmful interference, and

(2) This device must accept any interference received, including interference that may cause undesired operation.

NOTE: The grantee is not responsible for any changes or modifications not expressly approved by the party responsible for compliance. Such modifications could void the user's authority to operate the equipment.

This equipment has been tested and found to comply with the limits for a class B digital device, pursuant to part 15 of the FCC Rules. These limits are designed to provide reasonable protection against harmful interference in a residential installation. This equipment generates, uses and can radiate radio frequency energy and if not installed and used in accordance with the instructions, may cause harmful interference to radio communications. However, there is no guarantee that interference will not occur in a particular installation. If this equipment does cause harmful interference to radio or television reception, which can be determined by turning the equipment off and on, the user is encouraged to try to correct the interference by one or more of the following measures:

- Reorient or relocate the receiving antenna.
- Increase the separation between the equipment and receiver.
- Connect the equipment into an outlet on a circuit different from that to which the receiver is connected.
- Consult the dealer or an experienced radio/TV technician for help.

Caution to the user that changes or modifications not expressly approved by the party responsible for compliance could void the user's authority to operate the equipment.

8.4 POOLCOP EVOLUTION

Components	1.5" SG	2.0" SG
Valve Data Unit (VDU)	1	
pH Sensor Housing	Supplied	
Control Connection Unit (CCU)	1	
PoolCOP Base O-Ring	1	-
Adapter 2"	-	1
Adapter 2" O-Ring		1
Long Allen screws	2	-
Short Allen screws	4	-
Nuts and Washers	6	10
Diffuser with valve gasket 1.5"	1	-
Diffuser with valve gasket 2.0"	-	1
Technical Specifications		
CCU Dimensions	375x120x285 mm [14.8x4.8x11 in] - 4.3 Kg [9.5 lbs]	
VDU Dimensions	240x260x270 mm [9.4x10.2x10.6 in] - 3.2 Kg [7.0 lbs]	
Power Supply	230Vac, 50Hz	
Power supply fluctuations	+/- 10%	
Overvoltage category	II	
Pollution degree	2	
Usage	Indoor	
Service Temperature	-5°C- 45°C [23°F - 113°F]	
Altitude	2000m	
Relative humidity	80% up to 31°C, linear decrease down to 50% at 45°C	
Wet Location	The product has an enclosure that protected against splashing water, can be used in such wet location	
Current (Primary)	160mA	
Current (Secondary)	2A	
Battery 12V SLA	YUASA Y1.2-12FR	
1 x Pump + 7 Auxiliaries	6A - 230Vac	
Communications Port	RS 232	
Water Temperature Sensor	0 - 60°C [32°F - 140°F]	
Pressure Sensor	-0.9 - 2.50 Bars [-13 - 36 psi]	
Safety Features:	Loss of power supply AC (battery 12V SLA); no water; low pressure; high pressure; lightning protection	
CCU IP Rating	IP54	
VDU IP Rating	IP23	
Valve Performance US Units		

8.5 AIR TEMPERATURE SENSOR

Components	
Air Temperature Sensor with cable.	1
Technical Specifications	
Cable	4.5 m [4.8 ft]
Temperature Range (Accuracy)	-30°C - 65°C ($\Delta T = \pm 2^\circ\text{C}$) [-22°F - 149°F ($\Delta T = \pm 3.5^\circ\text{F}$)]

8.6 PH+ORP SENSORS

Components	SO4902	SO4903
pH+ORP sensor	1	1
Transport Cap	1	
-Retaining Screw	1	
Grip Washer	1	
Compression Ring	1	
O-Ring	1	
Technical Specifications		
Dimensions	Diameter 12 mm [0.47 in] – Length 14 cm [5.5 in]	
Cable	4 strands, 0.3 m [12 in]	
Connector	JST XHP-4	
pH Range (Accuracy)	4 - 12 (+/- 0.05)	
ORP Sensor Type	Platinum Pt	Gold Au
ORP Range (Accuracy)	0 - 999 mV (+/- 5 mV)	

8.7 FREE AVAILABLE CHLORINE SENSOR

See the **Free Available Chlorine Sensor Installer and User Manual** for information and guidance.

8.8 BACKUP WASTE VALVE

Components	
NC Valve	1
Control solenoid	2
PVC union set	2
63mm -> 50mm adapter	1
PVC saddle 63mm	1
PVC saddle 50mm	1
Vinyl tubing connection kit	3m
Technical Specifications	
Output solenoid	24 Vac
Service pressure	10 Bars [145 psi]
Membrane	Nylon reinforced

8.9 FLOW SWITCH

Components		
Flow Switch Sensor with cable.	1	
Technical Specifications		
Cable	4 m [6.6 ft]	
Service Temperature	5°C - 50°C [41°F - 122°F]	
Service Pressure	10 Bars [145 psi]	
Protection	IP65	
Pipe size	1.5"	2.0"
Flow sensing ON	Approx. 3 m ³ /h [11 gpm]	Approx. 4 m ³ /h [14.5 gpm]
Flow sensing OFF	Approx. 1 m ³ /h [3.6 gpm]	Approx. 1.5 m ³ /h [5.5 gpm]

8.10 WATER LEVEL CONTROL

Components	Waterline Kit	Buffer Tank Kit
Water level sensor/s	1 sensor	4 sensors
Solenoid valve	1	
PVC saddles 50mm	1	
PVC saddles 63mm	1	
90° PVC connector (20mm to 20mm)	1	
Straight PVC connector 20mm	2	
Non-return valve, brass	1	
Stop valve 15mm	1	
Reducing connector (20mm to 15mm)	1	
Technical Specifications		
Output Sensor	5VDC	
Output valve	24 Vac	
Service pressure	3.5 Bars [50.7 psi]	
Cable length	20 m [65.6 ft]	6m [19.7 ft]
Height	70mm [2.76 in]	40mm [1.58 in]
Width	45mm [1.77 in]	25mm [0.98 in]
Deep	15mm [0.59 in]	25mm [0.98 in]

8.11 XM8 EXTENSION MODULE

Components	PoolCOP XM8
XM8	1
Technical Specifications	
Dimensions	140x98x195 mm [5.5x3.9x7.7 in] - 0.8 Kg [1.76 lbs]
Power Supply	12V - 300mA
Auxiliary channel 9 to 15	6A - 24Vac
Inputs 3 to 10	5 VDC
Protection	IP54
Conformity	CE



PCFR SAS
130 Boulevard du Nord
84160 CUCURON, France